



# MX23L25611

## 256M-BIT (16M x 16/32M x 8) MASK ROM WITH PAGE MODE (SSOP ONLY)

### FEATURES

- Bit organization
  - 32M x 8 (byte mode)
  - 16M x 16 (word mode)
- Fast access time
  - Random access: 100ns (max.)
  - Page access: 30ns (max.)
- Page Size
  - 8 words per page
- Current
  - Operating: 30mA (max.) @ 5MHz
  - Standby: 15uA (max.)
- Supply voltage
  - 3.0V ~ 3.6V
- Package
  - 70 pin SSOP
- Temperature
  - 0~70° C

### PIN CONFIGURATION

#### 70 PIN SSOP

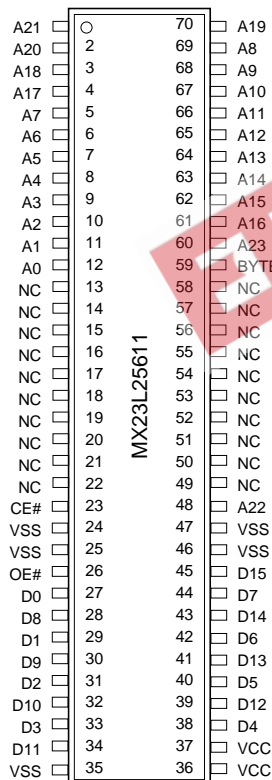

### PIN DESCRIPTION

Symbol	Pin Function
A0~A23	Address Inputs
D0~D14	Data Outputs
D15/A-1	D15 (Word Mode) / LSB Address (Byte Mode)
CE#	Chip Enable Input
OE#	Output Enable Input
BYTE#	Word/Byte Mode Selection
VCC	Power Supply Pin
VSS	Ground Pin
NC	No Connection

### MODE SELECTION

CE#	OE#	BYTE#	D15/A-1	D0~D7	D8~D15	Mode	Power
H	X	X	X	High Z	High Z	-	Stand-by
L	H	X	X	High Z	High Z	-	Active
L	L	H	Output	D0~D7	D8~D15	Word	Active
L	L	L	Input	D0~D7	High Z	Byte	Active

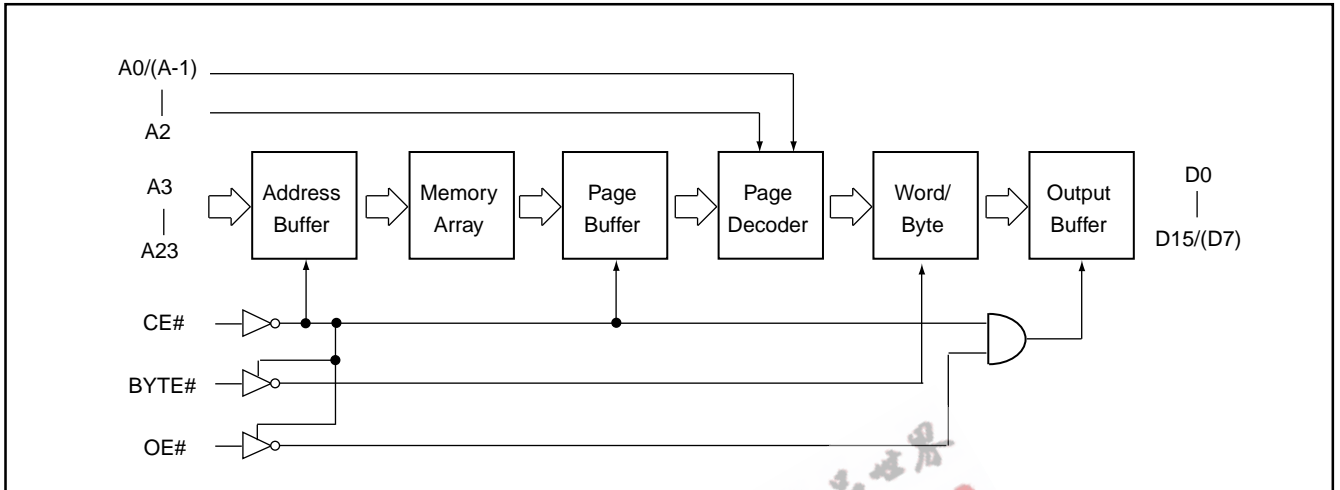
**BLOCK DIAGRAM**

**ORDER INFORMATION**

Part No.	Access Time	Package	VCC
MX23L25611MC-10	100ns	70 pin SSOP	3.0V~3.6V (under development)
MX23L25611MC-12	120ns	70 pin SSOP	3.0V~3.6V (under development)

**ABSOLUTE MAXIMUM RATINGS**

Item	Symbol	Ratings
Voltage on any Pin Relative to VSS	VIN	-0.3V to 3.9V
Ambient Operating Temperature	T <sub>opr</sub>	0°C to 70°C
Storage Temperature	T <sub>stg</sub>	-65°C to 125°C

**DC CHARACTERISTICS** (Ta = 0° C ~ 70° C, VCC = 3.0V ~ 3.6V)

Item	Symbol	MIN.	MAX.	Conditions
Output High Voltage	VOH	2.4V	-	IOH = -0.4mA
Output Low Voltage	VOL	-	0.4V	IOL = 1.6mA
Input High Voltage	VIH	2.2V	VCC+0.3V	
Input Low Voltage	VIL	-0.3V	0.2xVCC	
Input Leakage Current	ILI	-	10uA	0V, VCC
Output Leakage Current	ILO	-	10uA	0V, VCC
Operating Current	ICC	-	30mA	f=5MHz, all output open CE#=VIL(Chip Enable) OE#=VIH(Output Disabled)
Standby Current (TTL)	ISTB1	-	1mA	CE# = VIH
Standby Current (CMOS)	ISTB2	-	15uA	CE# > VCC-0.2V
Input Capacitance	CIN	-	10pF	Ta = 25° C, f = 1MHZ
Output Capacitance	COUT	-	10pF	Ta = 25° C, f = 1MHZ

**AC CHARACTERISTICS** (Ta = 0° C ~ 70° C, VCC = 3.0V ~ 3.6V)

Item	Symbol	23L25611-10		23L25611-12	
		MIN.	MAX.	MIN.	MAX.
Read Cycle Time	tRC	100ns	-	120ns	-
Address Access Time	tAA	-	100ns	-	120ns
Chip Enable Access Time	tCE	-	100ns	-	120ns
Page Mode Access Time	tPA	-	30ns	-	30ns
Output Enable Time	tOE	-	30ns	0	30ns
Output Hold After Address	tOH	0ns	-	0ns	-
Output High Z Delay	tHZ	-	20ns	-	20ns

**AC Test Conditions**

Input Pulse Levels	0.4V~ 2.4V
Input Rise and Fall Times	10ns
Input Timing Level	1.5V
Output Timing Level	1.5V
Output Load	See Figure

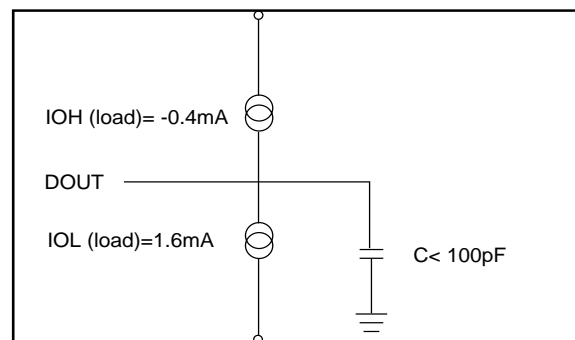

Note: No output loading is present in tester load board.

Active loading is used and under software programming control.

Output loading capacitance includes load board's and all stray capacitance.

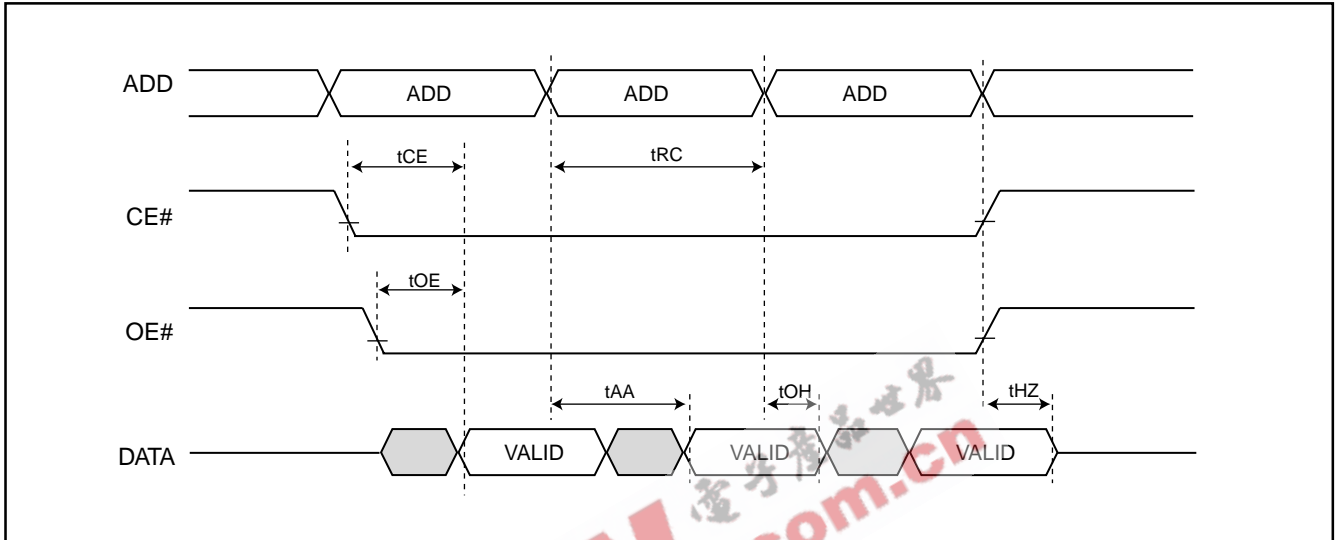
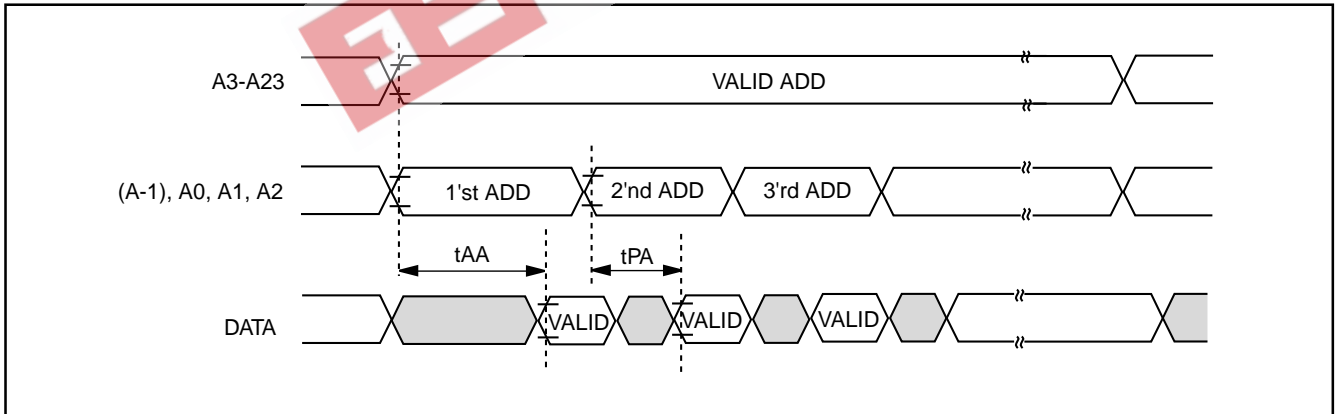
**TIMING DIAGRAM**
**RANDOM READ**

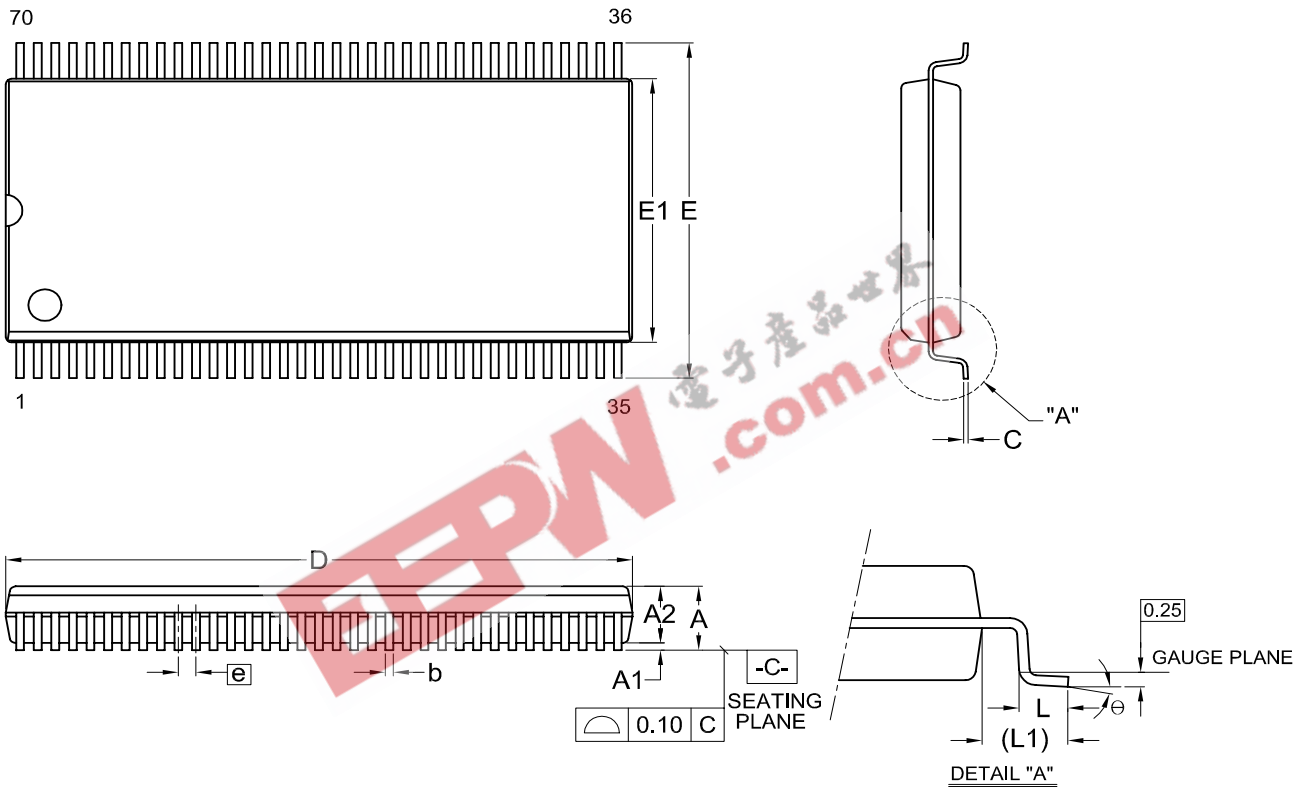
**PAGE READ**

**PACKAGE INFORMATION**
**Title: Package Outline for SSOP 70L (500MIL)**

Dimensions (inch dimensions are derived from the original mm dimensions)

SYMBOL		A	A1	A2	b	C	D	E	E1	e	L	L1	Ø
mm	Min.	---	0.10	2.56	0.30	0.17	28.37	15.73	12.47		0.61	1.51	0
	Nom.	---	0.15	2.69	0.35	0.20	28.50	16.03	12.60	0.80	0.81	1.71	5
	Max.	3.05	0.23	2.82	0.40	0.25	28.63	16.33	12.73		1.01	1.91	10
Inch	Min.	---	0.004	0.101	0.012	0.007	1.117	0.619	0.491		0.024	0.060	0
	Nom.	---	0.006	0.106	0.014	0.008	1.122	0.631	0.496	0.031	0.032	0.068	5
	Max.	0.120	0.009	0.111	0.016	0.010	1.127	0.643	0.501		0.040	0.075	10

DWG.NO.	REVISION	REFERENCE			ISSUE DATE
		JEDEC	EIAJ		
6110-1503	5				11-26-03

**REVISION HISTORY**

<b>Revision #</b>	<b>Description</b>	<b>Page</b>	<b>Date</b>
1.0	1. Changed heading as "RELIMINARY" 2. Modify Pin Configuration--Pin#6~15, Pin#24,25,68,69	P1 P1	SEP/06/2001
1.1	1. Modify Pin Configuration--Pin#10~14, 25,26	P1	SEP/07/2001
1.2	1. Modify Pin Configuration 2. Modify Operating Current:60mA-->30mA; Standby Current(CMOS):50uA-->15uA 3. Modify MODE SELECTION 4. Add 120ns in AC Characteristics 5. Add Order Informaion	P1 P1,2 P1 P3 P2	FEB/01/2002
1.3	6. Modify 70 pin SOP --> 70 pin SSOP Modify Package Information	P1,2,5 P5	NOV/21/2002

EEPW 电子产品世界  
.com.cn



**MX23L25611**

---

---

**MACRONIX INTERNATIONAL Co., LTD.**

**Headquarters:**

TEL:+886-3-578-6688

FAX:+886-3-563-2888

**Europe Office :**

TEL:+32-2-456-8020

FAX:+32-2-456-8021

**Hong Kong Office :**

TEL:+86-755-834-335-79

FAX:+86-755-834-380-78

**Japan Office :**

**Kawasaki Office :**

TEL:+81-44-246-9100

FAX:+81-44-246-9105

**Osaka Office :**

TEL:+81-6-4807-5460

FAX:+81-6-4807-5461

**Singapore Office :**

TEL:+65-6346-5505

FAX:+65-6348-8096

**Taipei Office :**

TEL:+886-2-2509-3300

FAX:+886-2-2509-2200

**MACRONIX AMERICA, INC.**

TEL:+1-408-262-8887

FAX:+1-408-262-8810

*<http://www.macronix.com>*

---