



MX23L3210

32M-BIT (4M x 8 / 2M x 16) Mask ROM

FEATURES

- Bit organization
 - 4M x 8 (byte mode)
 - 2M x 16 (word mode)
- Fast access time
 - Random access:70ns (max.) for 3.0V~3.6V
 - 90ns (max.) for 2.7V~3.6V
- Current
 - Operating:40mA
 - Standby:15uA
- Supply voltage
 - 2.7V~3.6V
- Package
 - 44 pin SOP (500mil)
 - 48 pin TSOP (12mm x 20mm)
 - 44 pin TSOP (Type II)

PIN CONFIGURATION

44 SOP/ 44 TSOP

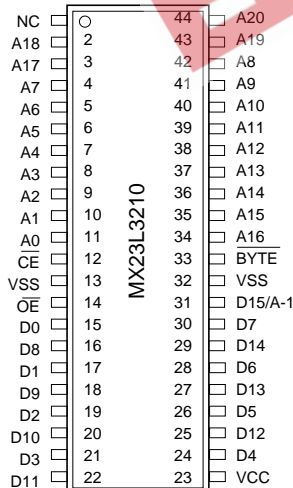

ORDER INFORMATION

Part No.	Access Time	Package
MX23L3210MC-10	100ns	44 pin SOP
MX23L3210MC-12	120ns	44 pin SOP
MX23L3210MC-15	150ns	44 pin SOP
MX23L3210TC-70	70ns	48 pin TSOP
MX23L3210TC-90	90ns	48 pin TSOP
MX23L3210TC-10	100ns	48 pin TSOP
MX23L3210TC-12	120ns	48 pin TSOP
MX23L3210TC-15	150ns	48 pin TSOP
MX23L3210RC-70	70ns	48 pin TSOP (Reverse type)
MX23L3210RC-90	90ns	48 pin TSOP (Reverse type)
MX23L3210RC-10	100ns	48 pin TSOP (Reverse type)
MX23L3210RC-12	120ns	48 pin TSOP (Reverse type)
MX23L3210RC-15	150ns	48 pin TSOP (Reverse type)
MX23L3210YC-10	100ns	44 pin TSOP
MX23L3210YC-12	120ns	44 pin TSOP

PIN DESCRIPTION

Symbol	Pin Function
A0~A20	Address Inputs
D0~D14	Data Outputs
D15/A-1	D15 (Word Mode)/ LSB Address (Byte Mode)
\overline{CE}	Chip Enable Input
\overline{OE}	Output Enable Input
Byte	Word/ Byte Mode Selection
VCC	Power Supply Pin
VSS	Ground Pin
NC	No Connection

MODE SELECTION

\overline{CE}	\overline{OE}	Byte	D15/A-1	D0~D7	D8~D15	Mode	Power
H	X	X	X	High Z	High Z	-	Stand-by
L	H	X	X	High Z	High Z	-	Active
L	L	H	Output	D0~D7	D8~D15	Word	Active
L	L	L	Input	D0~D7	High Z	Byte	Active



MX23L3210

48 TSOP (Normal Type)



48 TSOP (Reverse Type)

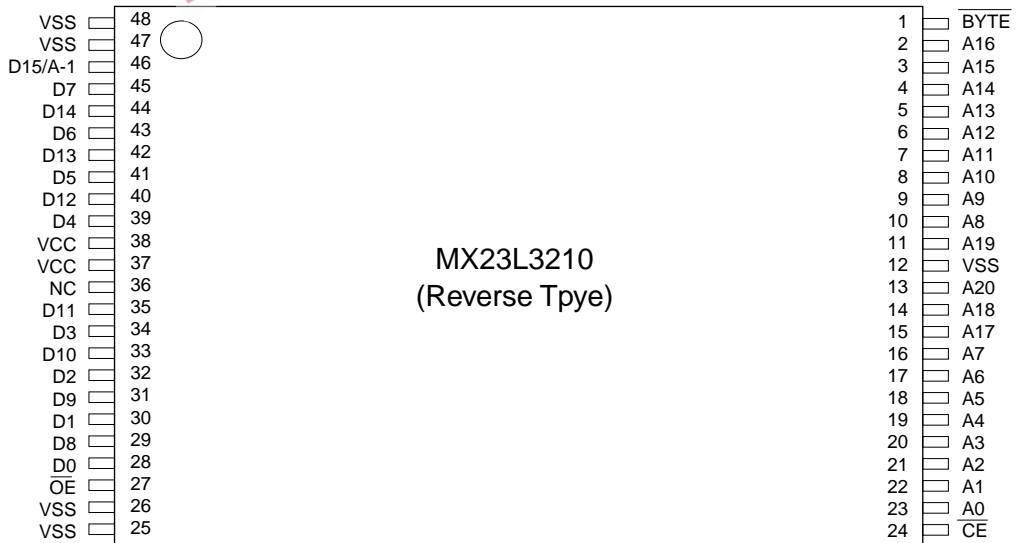

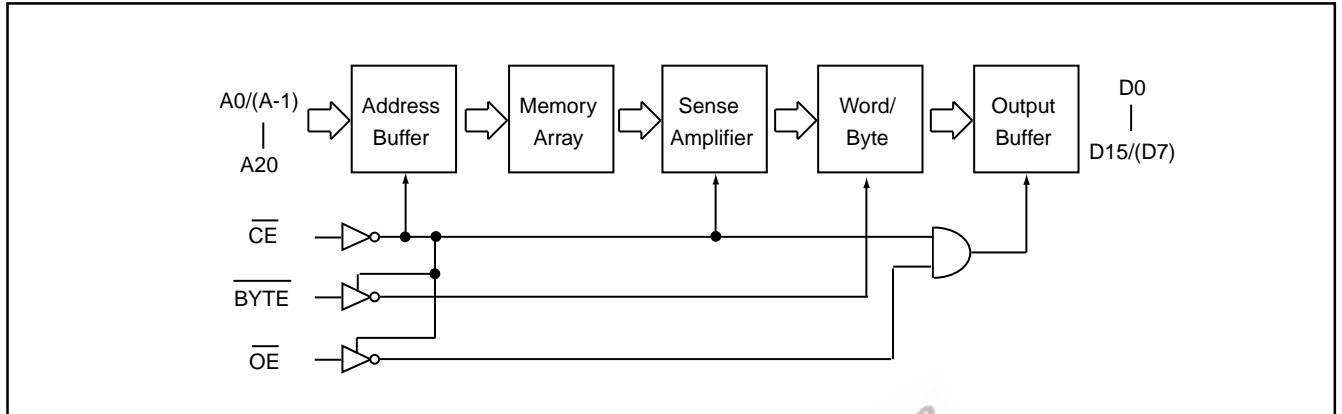
BLOCK DIAGRAM

ABSOLUTE MAXIMUM RATINGS

Item	Symbol	Ratings
Voltage on any Pin Relative to VSS	V _{IN}	-0.3V to 3.9V
Ambient Operating Temperature	T _{opr}	0°C to 70°C
Storage Temperature	T _{stg}	-65°C to 125°C

DC CHARACTERISTICS (T_a = 0°C ~ 70°C, VCC = 2.7V~3.6V)

Item	Symbol	MIN.	MAX.	Conditions
Output High Voltage	V _{OH}	2.3V	-	I _{OH} = -0.4mA
Output Low Voltage	V _{OL}	-	0.4V	I _{OL} = 1.6mA
Input High Voltage	V _{IH}	2.1V	VCC+0.3V	
Input Low Voltage	V _{IL}	-0.3V	0.2xVCC	
Input Leakage Current	I _{LI}	-	5uA	0V, VCC
Output Leakage Current	I _{LO}	-	5uA	0V, VCC
Operating Current	I _{CC1}	-	40mA	t _{RC} = 120ns, all output open
Standby Current (TTL)	I _{STB1}	-	1mA	$\overline{CE} = V_{IH}$
Standby Current (CMOS)	I _{STB2}	-	15uA	$\overline{CE} > VCC - 0.2V$
Input Capacitance	C _{IN}	-	10pF	T _a = 25°C, f = 1MHZ
Output Capacitance	C _{OUT}	-	10pF	T _a = 25°C, f = 1MHZ

AC CHARACTERISTICS (Ta = 0°C ~ 70°C, VCC = 3.0V~3.6V)

Item	Symbol	23L3210-70		23L3210-90		23L3210-10		23L3210-12		23L3210-15	
		MIN.	MAX.	MIN.	MAX.	MIN.	MAX.	MIN.	MAX.	MIN.	MAX.
Read Cycle Time	tRC	70ns	-	90ns	-	100ns	-	120ns	-	150ns	-
Address Access Time	tAA	-	70ns	-	90ns	-	100ns	-	120ns	-	150ns
Chip Enable Access Time	tACE	-	70ns	-	90ns	-	100ns	-	120ns	-	150ns
Output Enable Time	tOE	-	35ns	-	45ns	-	50ns	-	60ns	-	70ns
Output Hold After Address	tOH	0ns	-	0ns	-	0ns	-	0ns	-	0ns	-
Output High Z Delay	tHZ	-	20ns	-	20ns	-	20ns	-	20ns	-	20ns

Note: Output high-impedance delay (tHZ) is measured from OE going high, and this parameter guaranteed by design over the full voltage and temperature operating range - not tested.

AC Test Conditions

Input Pulse Levels	0.4V~2.4V
Input Rise and Fall Times	10ns
Input Timing Level	1.4V
Output Timing Level	1.4
Output Load	See Figure

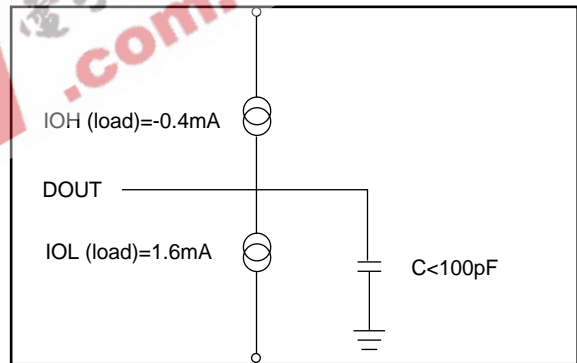

Note: No output loading is present in tester load board.
Active loading is used and under software programming control.
Output loading capacitance includes load board's and all stray capacitance.

TIMING DIAGRAM

RANDOM READ

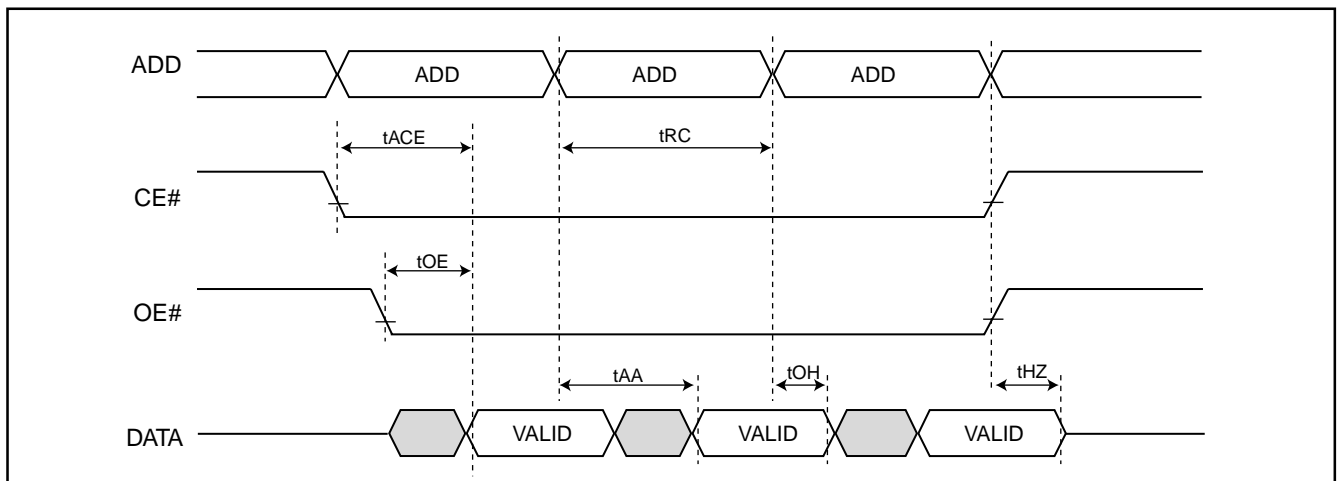

PACKAGE INFORMATION

Title: Package Outline for SOP 44L (500MIL)

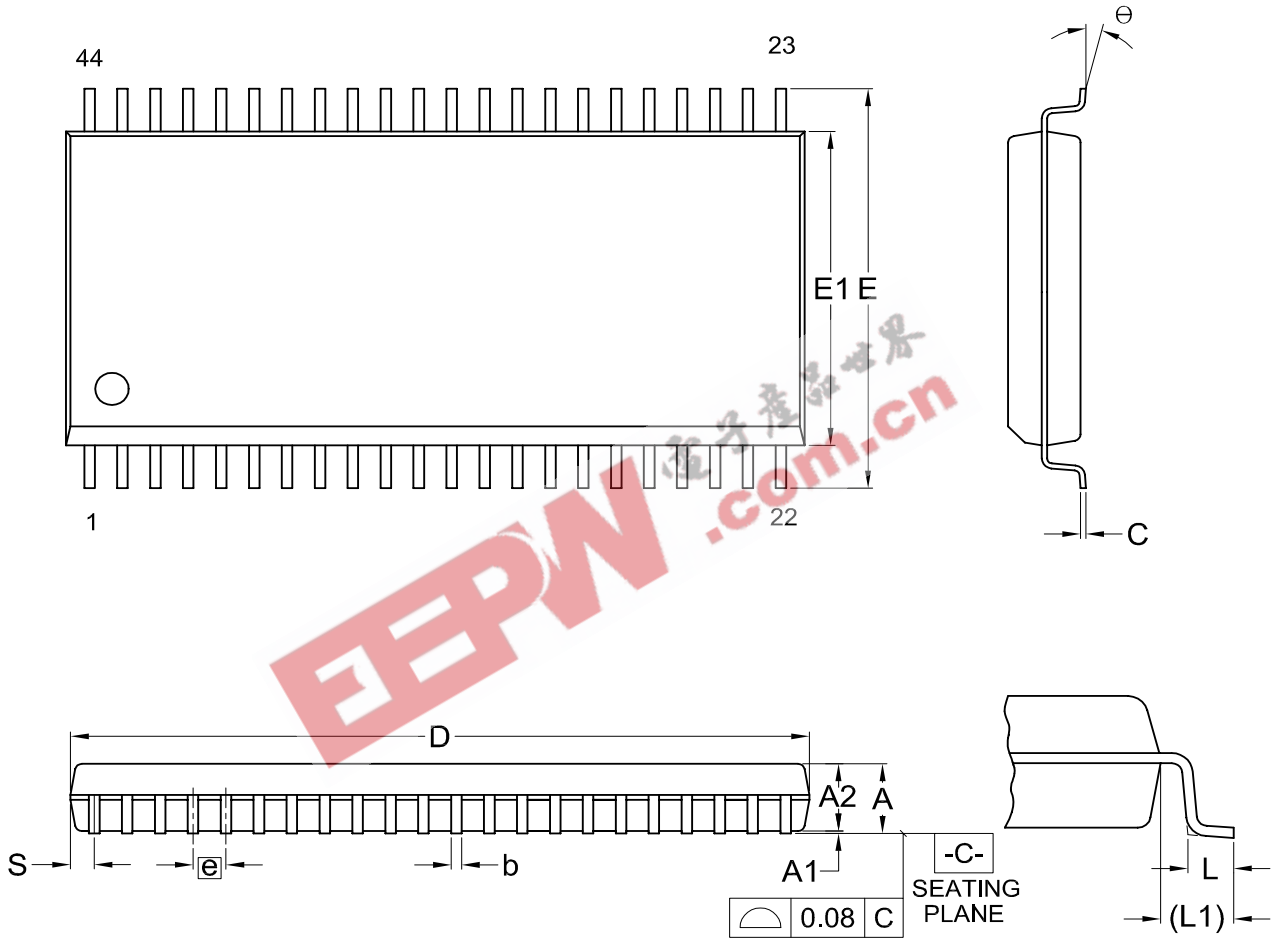

Dimensions (inch dimensions are derived from the original mm dimensions)

SYMBOL		A	A1	A2	b	C	D	E	E1	e	L	L1	S	θ
UNIT														
mm	Min.	---	0.10	2.59	0.36	0.15	28.37	15.83	12.47		0.56	1.51	0.78	0
	Nom.	---	0.15	2.69	0.41	0.20	28.50	16.03	12.60	1.27	0.76	1.71	0.91	5
	Max.	3.00	0.20	2.80	0.51	0.25	28.63	16.23	12.73		0.96	1.91	1.04	10
Inch	Min.	---	0.004	0.102	0.014	0.006	1.117	0.623	0.491		0.022	0.059	0.031	0
	Nom.	---	0.006	0.106	0.016	0.008	1.122	0.631	0.496	0.050	0.030	0.067	0.036	5
	Max.	0.118	0.008	0.110	0.020	0.010	1.127	0.639	0.501		0.038	0.075	0.041	10

DWG.NO.	REVISION	REFERENCE			ISSUE DATE
		JEDEC	EIAJ		
6110-1405	6	MO-175			11-26-'03

Title: Package Outline for TSOP(II) 44L (400MIL)

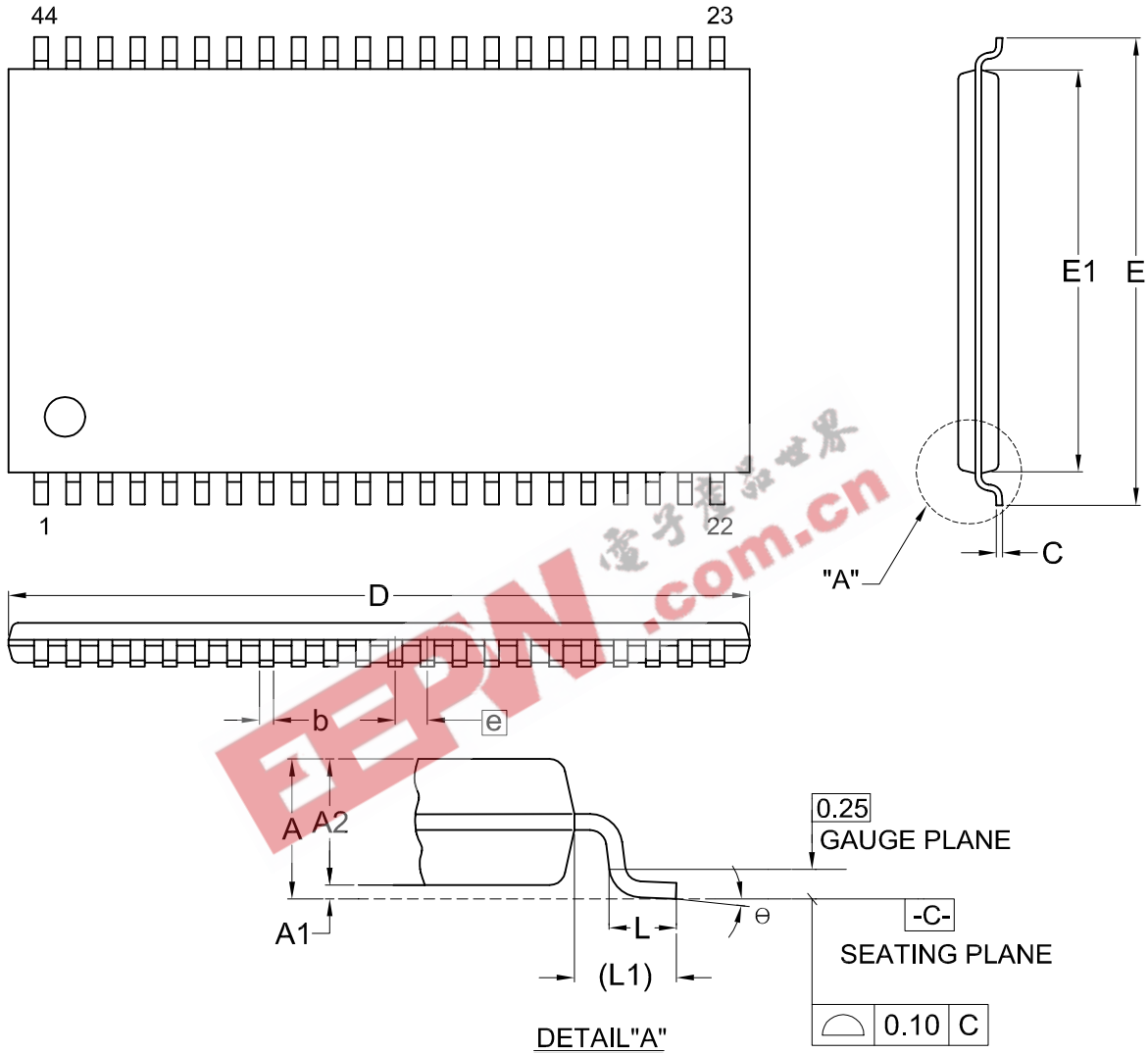

Dimensions (inch dimensions are derived from the original mm dimensions)

SYMBOL		A	A1	A2	b	C	D	E	E1	e	L	L1	θ
UNIT													
mm	Min.	---	0.05	0.95	0.30	0.12	18.31	11.56	10.06		0.40	0.70	0
	Nom.	---	0.10	1.00	0.35	0.15	18.41	11.76	10.16	0.80	0.50	0.80	5
	Max.	1.20	0.15	1.05	0.45	0.21	18.51	11.96	10.26		0.60	0.90	8
Inch	Min.	---	0.002	0.037	0.012	0.005	0.721	0.455	0.396		0.016	0.028	0
	Nom.	---	0.004	0.039	0.014	0.006	0.725	0.463	0.400	0.031	0.020	0.031	5
	Max.	0.047	0.006	0.041	0.018	0.008	0.729	0.471	0.404		0.024	0.035	8

DWG.NO.	REVISION	REFERENCE			ISSUE DATE
		JEDEC	EIAJ		
6110-1701	6	MS-024			12-01-03

Title: Package Outline for TSOP(I) 48L (12X20mm)NORMAL FORM

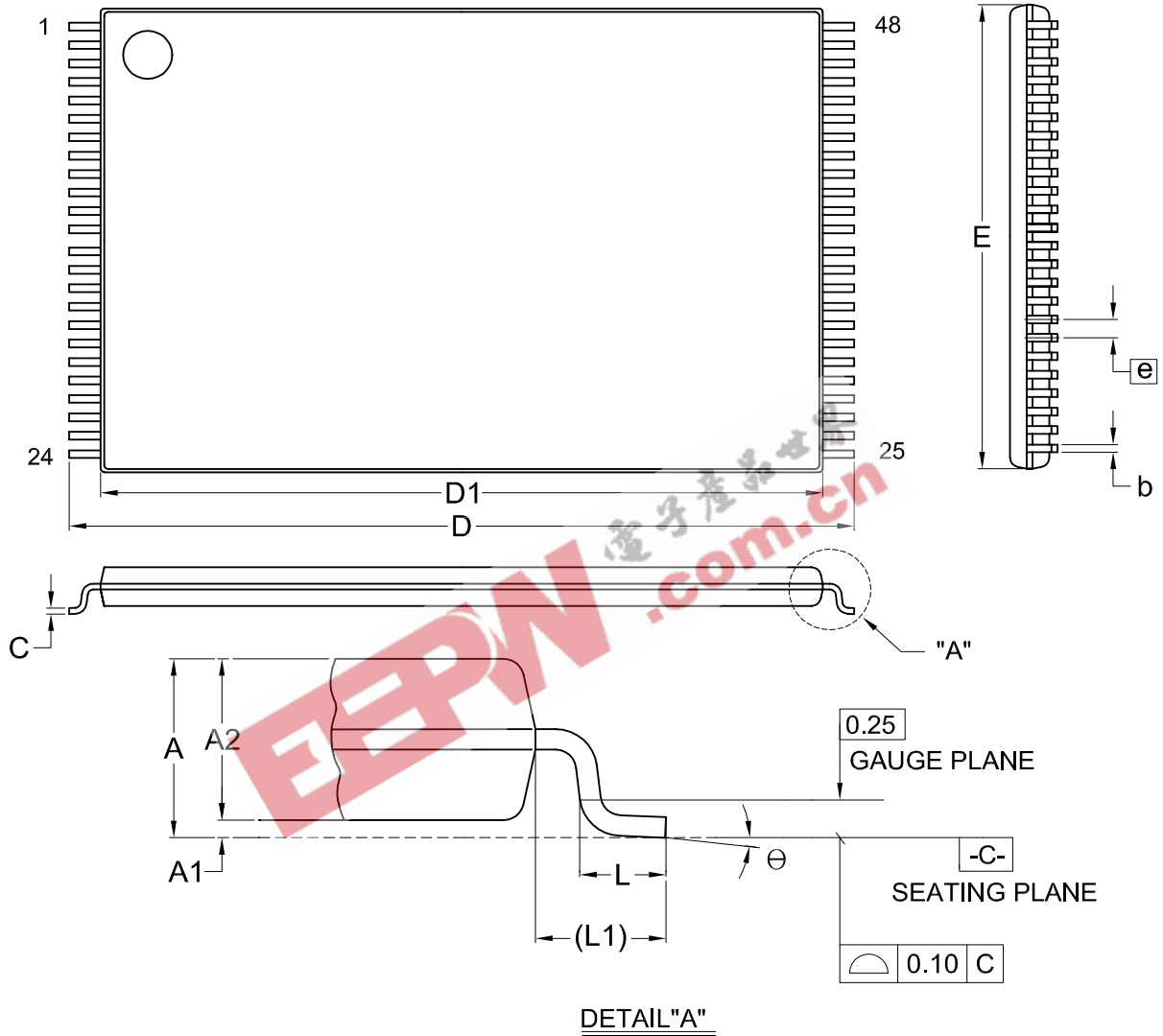

Dimensions (inch dimensions are derived from the original mm dimensions)

SYMBOL		A	A1	A2	b	C	D	D1	E	e	L	L1	θ
UNIT													
mm	Min.	---	0.05	0.95	0.17	0.10	19.80	18.30	11.90		0.50	0.70	0
	Nom.	---	0.10	1.00	0.20	0.13	20.00	18.40	12.00	0.50	0.60	0.80	5
	Max.	1.20	0.15	1.05	0.27	0.21	20.20	18.50	12.10		0.70	0.90	8
Inch	Min.	---	0.002	0.037	0.007	0.004	0.780	0.720	0.469		0.020	0.028	0
	Nom.	---	0.004	0.039	0.008	0.005	0.787	0.724	0.472	0.020	0.024	0.031	5
	Max.	0.047	0.006	0.041	0.011	0.008	0.795	0.728	0.476		0.028	0.035	8

DWG.NO.	REVISION	REFERENCE			ISSUE DATE
		JEDEC	EIAJ		
6110-1607	7	MO-142			12-01-03

Title: Package Outline for TSOP(I) 48L (12X20mm)REVERSE FORM

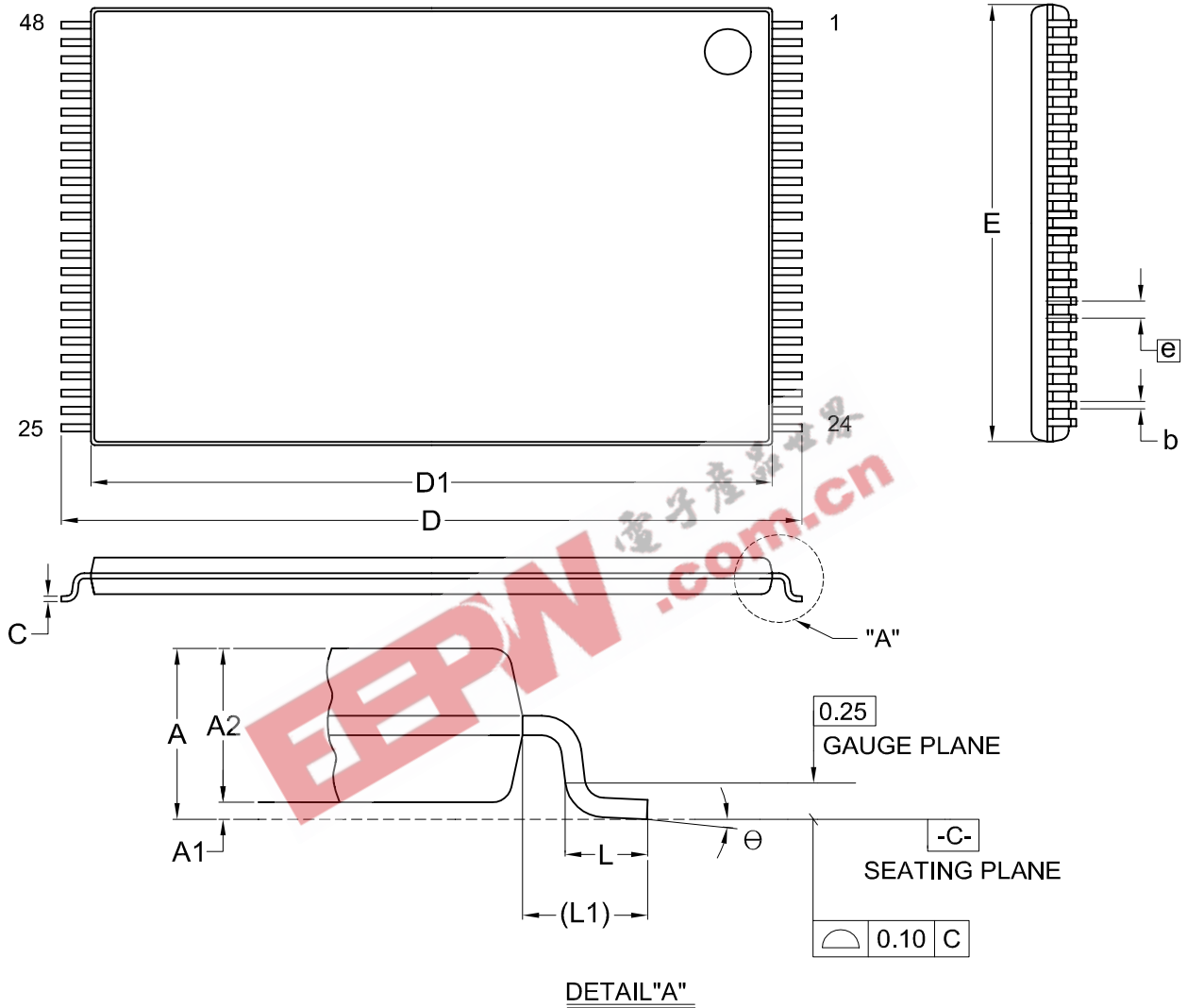

Dimensions (inch dimensions are derived from the original mm dimensions)

SYMBOL		A	A1	A2	b	C	D	D1	E	e	L	L1	θ
UNIT													
mm	Min.	---	0.05	0.95	0.17	0.10	19.80	18.30	11.90		0.50	0.70	0
	Nom.	---	0.10	1.00	0.20	0.13	20.00	18.40	12.00	0.50	0.60	0.80	5
	Max.	1.20	0.15	1.05	0.27	0.21	20.20	18.50	12.10		0.70	0.90	8
Inch	Min.	---	0.002	0.037	0.007	0.004	0.780	0.720	0.469		0.020	0.028	0
	Nom.	---	0.004	0.039	0.008	0.005	0.787	0.724	0.472	0.020	0.024	0.031	5
	Max.	0.047	0.006	0.041	0.011	0.008	0.795	0.728	0.476		0.028	0.035	8

DWG.NO.	REVISION	REFERENCE			ISSUE DATE
		JEDEC	EIAJ		
6110-1607.1	7	MO-142			12-01-03

REVISION HISTORY

REVISION	DESCRIPTION	PAGE	DATE
2.5	AC CHARACTERISTICS tOH 10ns-->0ns	P4	JAN/29/1999
2.6	Add 120ns (max.) for 3.0V~3.6V ; 150ns(max.) for 2.7V~3.6V DC characteristics Standby current (ISTB2):5uA-->15uA AC characteristics 120ns for 3.0V~3.6V	P1 P1,3 P4	Dec/24/1999
2.7	1. Added access time:100ns 2. Modify Package Information	P1,4 P5,6	JUN/28/2001
2.8	1. Added 44-pin TSOP(II)	P1,7	JUL/17/2001
2.9	1. Added access time:70ns & 90ns	P1,4	MAY/14/2002
3.0	Modify Package Information	P5~8	NOV/21/2002
3.1	Change 2.7~3.6V 150ns-->2.7~3.6V 90ns	P1	MAY/19/2004

EEPW 电子產品世界
.com.cn



MX23L3210

MACRONIX INTERNATIONAL CO., LTD.

Headquarters:

TEL:+886-3-578-6688

FAX:+886-3-563-2888

Europe Office :

TEL:+32-2-456-8020

FAX:+32-2-456-8021

Hong Kong Office :

TEL:+86-755-834-335-79

FAX:+86-755-834-380-78

Japan Office :

Kawasaki Office :

TEL:+81-44-246-9100

FAX:+81-44-246-9105

Osaka Office :

TEL:+81-6-4807-5460

FAX:+81-6-4807-5461

Singapore Office :

TEL:+65-6346-5505

FAX:+65-6348-8096

Taipei Office :

TEL:+886-2-2509-3300

FAX:+886-2-2509-2200

MACRONIX AMERICA, INC.

TEL:+1-408-262-8887

FAX:+1-408-262-8810

<http://www.macronix.com>
