

WORLDWIDE

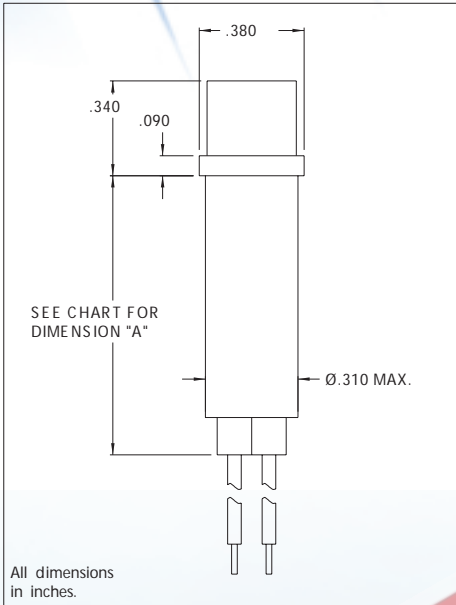

2150A, 2151A, 2112A, 2152A, 2153A and 2194A Series Non-Relampable Neon-Incandescent Indicator Lights

DESCRIPTION AND FEATURES



Mounting: Ø.310 MIN., supplied with push-on speednut SN1287.

Wire Leads: No.22 AWG (105°C) 4.40/4.80 long, stripped .430/.570

Lens: Polycarbonate-neon transparent, incandescent-translucent

Bezel: Polished stainless steel. For black finish add "X" after the series letter(s).

Housing: White Nylon

电子产品世界
EPW.com.cn

Lens Color	Neon		Incandescent	
	Model No. (105-125VAC)	Model No. (208-250VAC)	Model No. (12V)	Model No. (28V)
Red	2150A1	2151A1	2194A1-12V	2194A1-28V
Clear	2150A2	2151A2	-	-
Amber	2150A3	2151A3	2194A3-12V	2194A3-28V
White	2150A4	2151A4	2194A4-12V	2194A4-28V
Green	2152A5*	2153A5*	2194A5-12V	2194A5-28V
Blue	2152A6**	2153A6**	-	-
Lamp used	C2A+R resistor	C2A+R resistor	#2162	#2187
Lead Color	Black	Black/Red	Yellow	Purple
"A" DIM	1.310	1.310	.830	.830

* Incorporates G2B lamp and resistor.

** Incorporates T2B lamp and resistor.

Underwriters Laboratories (UL) File No. E20325

Canadian Standards Association (CSA) File No. LR13346



America:
CML Innovative Technologies, Inc.
147 Central Avenue
Hackensack, NJ 07601 -USA
Tel:1-201-489 -8989
Fax:1-201-489 -6911
e-mail:americas@cml-it.com

Europe:
CML Technologies GmbH &Co.KG
Robert-Bunsen-Str.1
67098 Bad Dürkheim -GERMANY
Tel:+49 (0)6322 9567-0
Fax:+49 (0)6322 9567-88
e-mail:europe@cml-it.com

Asia:
CML Innovative Technologies, Inc.
61 Aida Street
Singapore 459975
Tel:(65)9630 -5003
e-mail:asia@cml-it.com

2150A, 2151A, 2112A, 2152A, 2153A and 2194A Series Non-Relampable Neon-Incandescent Indicator Lights