

WORLDWIDE

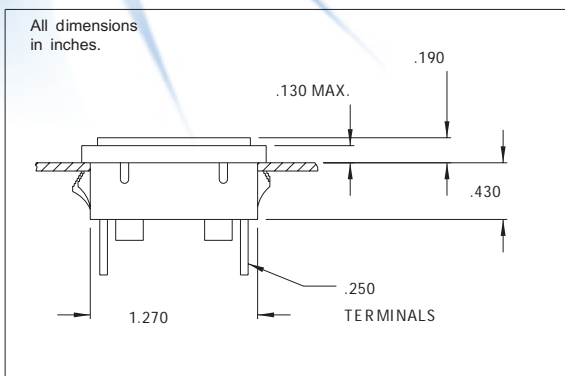

2330QD, 2332QD and 2390QD Series Non-Relampable Neon-Incandescent Indicator Lights

DESCRIPTION AND FEATURES



Mounting: Will snap-fit into .032/.100 thick panel, use speednut for other panel thicknesses. Available with speednut SN1963. Mounting hole pattern on page SP3.

Terminals: Quick-connect, tinned brass.

Lens: Polycarbonate

Bezel: Polished stainless steel. For black finish add "X" after the series letter(s).

Lens Color	Incandescent	
	Model No. (105-125VAC) .250 Terminals	Model No. (28V) .250 Terminals
Red	2330QD1	2390QD1-28V
Amber	2330QD3	2390QD3-28V
White	2330QD4	2390QD4-28V
Green	2332QD5*	2390QD5-28V
Lamp used	C6 A+Resistor	#2187

*Incorporates G2B lamp and resistor
Underwriters Laboratories (UL) File No. E20325
Canadian Standards Association (CSA) File No. LR13346

2330QD, 2332QD and 2390QD Series
Non-Relampable Neon-Incandescent Indicator Lights



America:
CML Innovative Technologies, Inc.
147 Central Avenue
Hackensack, NJ 07601 -USA
Tel: 1-201-489-8989
Fax: 1-201-489-6911
e-mail: americas@cml-it.com

Europe:
CML Technologies GmbH & Co. KG
Robert-Bunsen-Str. 1
67098 Bad Dürkheim - GERMANY
Tel: +49 (0)6322 9567-0
Fax: +49 (0)6322 9567-88
e-mail: europe@cml-it.com

Asia:
CML Innovative Technologies, Inc.
61 Aida Street
Singapore 459975
Tel: (65)9630-5003
e-mail: asia@cml-it.com