

IMX 7 Series

7 Watt DC-DC Converters



Wide input voltage ranges up to 150 V DC
1 or 2 outputs up to 48 V DC
1500...2500 V DC I/O electric strength test



- Magnetic feedback for single output models
- Short circuit protection
- Industry standard 2" x 1" case with 10.5 mm profile

Selection chart

Output 1		Output 2		Input voltage	Type	Options ^{1,2}
U_o nom [V DC]	I_o nom [A]	U_o nom [V DC]	I_o nom [mA]	U_i [V DC]		
3.3	1.5	-	-	8.4...36	20 IMX 7-03-9	-8, M, C, L, Z
3.3	1.5	-	-	16.8...75	40 IMX 7-03-9 ³	-8, M, C, L, Z
3.3	1.5	-	-	40...121	70 IMX 7-03-9	-8, M
3.3	1.5	-	-	60...150	110 IMX 7-03-9	-8, M
5.1	1.2	-	-	8.4...36	20 IMX 7-05-9	-8, M, C, L, Z
5.1	1.2	-	-	16.8...75	40 IMX 7-05-9 ³	-8, M, C, L, Z
5.1	1.2	-	-	40...121	70 IMX 7-05-9	-8, M
5.1	1.2	-	-	60...150	110 IMX 7-05-9	-8, M
12	0.5	-	-	8.4...36	20 IMX 7-12-9C	-8
12	0.6	-	-	16.8...75	40 IMX 7-12-9C ³	-8
15	0.4	-	-	8.4...36	20 IMX 7-15-9C	-8
15	0.48	-	-	16.8...75	40 IMX 7-15-9C ³	-8
24	0.26	-	-	8.4...36	20 IMX 7-24-9C	-8
24	0.3	-	-	16.8...75	40 IMX 7-24-9C ³	-8
5	0.7	5	0.7	8.4...36	20 IMX 7-05-05-9	-8, M, C, L, Z
5	0.7	5	0.7	16.8...75	40 IMX 7-05-05-9 ³	-8, M, C, L, Z
5	0.7	5	0.7	40...121	70 IMX 7-05-05-9	-8, M
5	0.7	5	0.7	60...150	110 IMX 7-05-05-9	-8, M
12	0.3	12	0.3	8.4...36	20 IMX 7-12-12-9	-8, M, C, L, Z
12	0.3	12	0.3	16.8...75	40 IMX 7-12-12-9 ³	-8, M, C, L, Z
12	0.3	12	0.3	40...121	70 IMX 7-12-12-9	-8, M
12	0.3	12	0.3	60...150	110 IMX 7-12-12-9	-8, M
15	0.24	15	0.24	8.4...36	20 IMX 7-15-15-9	-8, M, C, L, Z
15	0.24	15	0.24	16.8...75	40 IMX 7-15-15-9 ³	-8, M, C, L, Z
15	0.24	15	0.24	40...121	70 IMX 7-15-15-9	-8, M
15	0.24	15	0.24	60...150	110 IMX 7-15-15-9	-8, M
24	0.15	24	0.15	8.4...36	20 IMX 7-24-24-9	-8, M, C, L, Z
24	0.15	24	0.15	16.8...75	40 IMX 7-24-24-9 ³	-8, M, C, L, Z
24	0.15	24	0.15	40...121	70 IMX 7-24-24-9	-8, M
24	0.15	24	0.15	60...150	110 IMX 7-24-24-9	-8, M

¹ For minimum order quantity and lead time contact Power-One.

² Option M, C, L and Z exclude each other.

³ Operation at lower input voltage possible: P_o approx. 80% of $P_{o, nom}$ at $U_{i, min} = 14.4$ V

Input

Input voltage range	20 IMX 7	8.4...36 V DC
	40 IMX 7	16.8...75 V DC
	70 IMX 7	40...121 V DC
	110 IMX 7	60...150 V DC

Output

Output voltage setting accuracy	$U_{i \text{ nom}}$, 50% $I_{o \text{ nom}}$, single output models	$\pm 0.5\% U_{o \text{ nom}}$
	$U_{i \text{ nom}}$, 50% $I_{o \text{ nom}}$, double outp., main/aux. outp.	$\pm 1\% / \pm 1.2\% U_{o \text{ nom}}$
Minimum load	recommended for double output models	10% $I_{o \text{ nom}}$
Line/load regulation	$U_{i \text{ min}} \dots U_{i \text{ max}}$, 50% $I_{o \text{ nom}}$, single output models	$\pm 1\% U_{o \text{ nom}}$
Line regulation	$U_{i \text{ nom}}$, 50% $I_{o \text{ nom}}$, double output models	$\pm 1\% U_{o \text{ nom}}$
Load regulation	$U_{i \text{ nom}}$, 10...100% $I_{o \text{ nom}}$, double outp. models, main outp.	$\pm 3\% U_{o \text{ nom}}$
	tracking output	$\pm 3\% U_{o \text{ nom}}$
Output voltage switching noise	$U_{i \text{ nom}}$, 0...100% $I_{o \text{ nom}}$, peak-peak, total	max. 1.5% $U_{o \text{ nom}}$
Efficiency	$U_{i \text{ nom}}$, $I_{o \text{ nom}}$	up to 84%

Control and protection

Input protection	suppressor diode	
Overload protection	$U_{i \text{ min}} \dots U_{i \text{ max}}$, fully protected, hiccup mode	
No-load protection		
Remote shut down	TTL-compatible inhibit input	disabled with $\geq 2.4 \text{ V}$
Trim input for U_o		

Safety and EMC

Electric strength test voltage	I/O (20/40/70/110 IMX7)	1500/1500/2000/2500 V DC
Electromagnetic interference	with external filter	class B

Environmental

Operating ambient temperature	$U_{i \text{ nom}}$, $I_{o \text{ nom}}$	-25...71 °C
Storage temperature	non operational	-40...100 °C
Relative humidity	non condensing	93%
MTBF	G_B 40 °C, MIL-HDBK-217F, N2	1'650'000 h

Options

Extended temperature range	-40...85 °C, ambient, operating	-8
SMD version	with pins	M
SMD version	with adapter PCB	L
Open frame without case		Z
C-pinout		C

Accessories

DIN and chassis mounting bracket	
----------------------------------	--

IMX 7 Series

7 Watt DC-DC Converters

Mechanical data

Tolerances ± 0.3 mm (0.012") unless otherwise indicated.



IMX 7

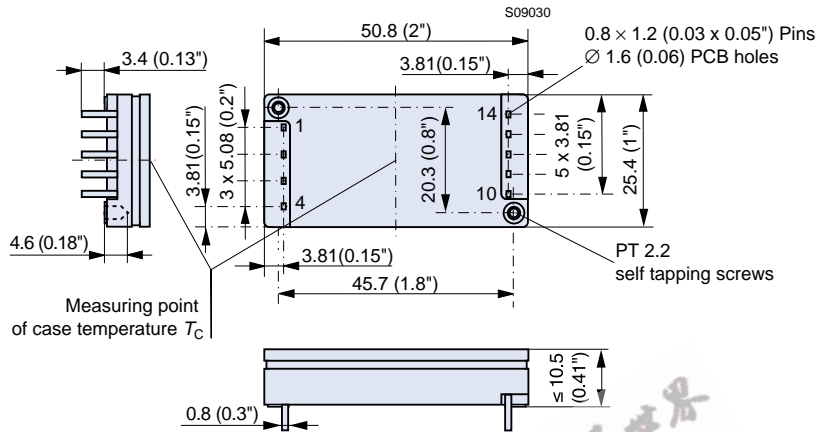

IMX 7 (option Z)

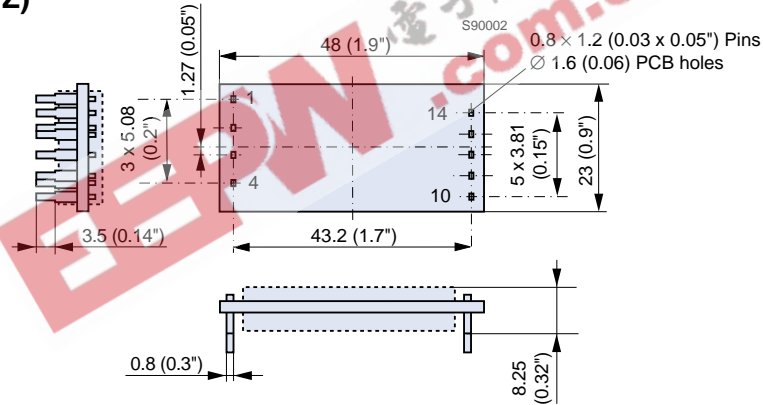

IMX 7 (option C)

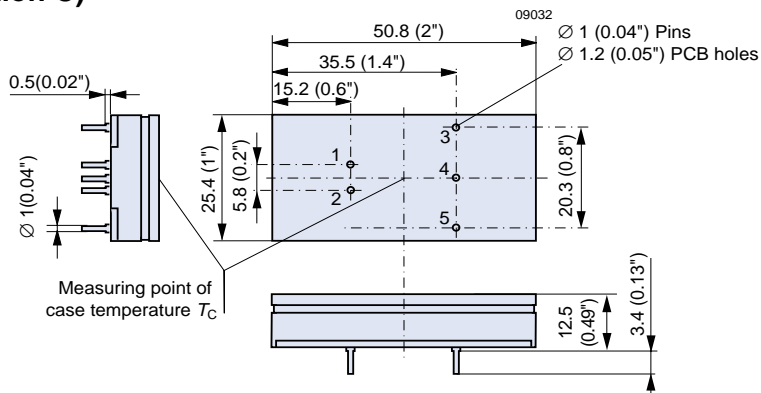

IMX 7 SMD version (option M)

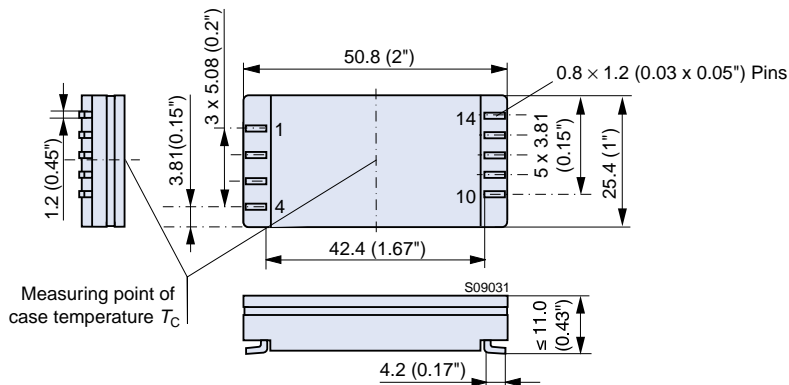

IMX 7 SMD version (option L)

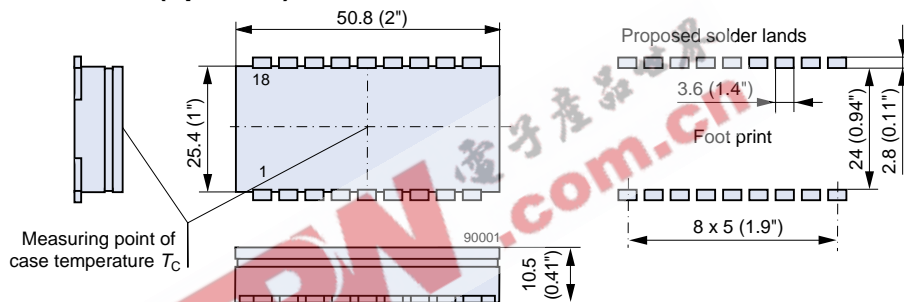

Pin allocation IMX 7, option M and Z

Pin	Single output	Dual output
1	Vi+	Vi+
2	Vi-	Vi-
3	i	i
4	n.c.	R (Trim)
10	Vo-	Vo1-
11	Vo+	Vo1+
12	Vo-	Vo2-
13	R	Vo2+
14	n.c.	n.c.

SMD version (option L)

Pin	Single output	Dual output
1	Vo	Vo1
2	Go	Go
3	n.c.	Vo2
4	n.c.	n.c.
5	n.c.	n.c.
6	n.c.	n.c.
7	n.c.	n.c.
8	n.c.	n.c.
9	n.c.	Trim
10	n.c.	n.c.
11	i	i
12	no pin	no pin
13	no pin	no pin
14	n.c.	n.c.
15	n.c.	n.c.
16	n.c.	n.c.
17	Vi-	Vi-
18	Vi+	Vi+

C pinout (option C)

Pin	Single output	Dual output
1	Vi+	Vi+
2	Vi-	Vi-
3	Vo+	Vo+
4	no pin	Go
5	Vo-	Vo-