

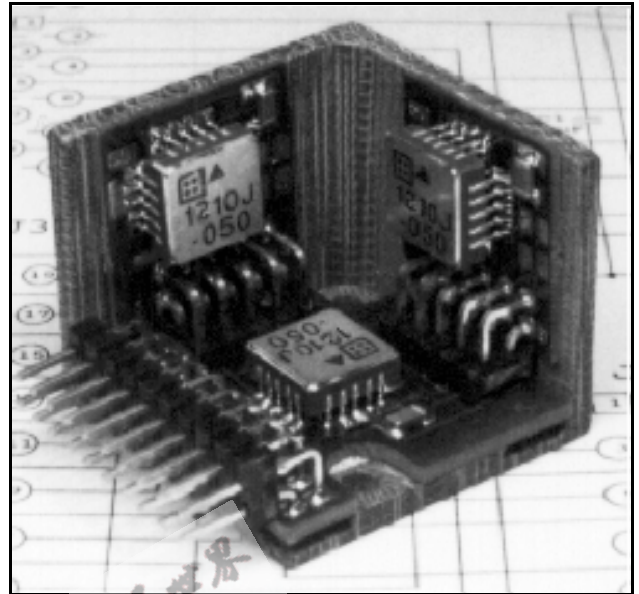

- 3 Axis Acceleration Sensing
- Contains 3 Model 1210 Capacitive Micromachined Accelerometers
- Built-in Nitrogen Damping
- $\pm 4V$ Differential & .5V to 4.5V Single Ended Outputs
- Low Cost Open Frame Design
- -40 to +85°C Operation
- +5 V DC, 21 mA Power (typical)
- Responds to DC & AC Acceleration
- Non Standard Ranges Available
- No External Reference Voltage Required
- Serialized for Traceability



DESCRIPTION The Model 2412 is a three axis, open frame accelerometer assembly for use in zero to medium frequency instrumentation applications. It contains three Model 1210 analog capacitive accelerometers orthogonally mounted on a phenolic frame. Overall size is 1.2" x 1.2" x 1.0", weight is 16 grams, and it is easily mounted via two #4 (or M3) screws (not included). An optional calibration test sheet (2412-TST) is also available which lists the measured bias, operating current and frequency response.

OPERATION The Model 2412 accelerometer produces three individual analog outputs which can be used either in differential or single ended modes referenced to +2.5 volts. The voltage of each output is proportional to the orthogonal component of the applied acceleration. The Model 2412 operates with a single +5 volt power supply and generates its own +2.5 volt reference with an on-board resistive divider. The three sensitive axes are perpendicular to the bottom of each of the individual accelerometer packages, with positive acceleration defined as a force pushing on the bottom of the package.

ORDERING INFORMATION

Full Scale Acceleration	Model Number
± 5 G	2412-005
± 10 G	2412-010
± 25 G	2412-025
± 50 G	2412-050
± 100 G	2412-100

PERFORMANCE Operating current is three times the current specified on the Model 1210 data sheet. Bias Calibration Error is derated from the model 1210 accelerometer to 1.5% typical and 3% max. For all other performance data, absolute maximum ratings and detailed descriptions of the AOP, AON and DV signals, please refer to Silicon Designs' Model 1210 data sheet.

MOUNTS VIA TWO #4 (or M3) SCREWS.

CONNECTION IS VIA STANDARD 20 CONDUCTOR RIBBON CABLE (0.05" CENTERS) & CONNECTOR (0.10" CENTERS).

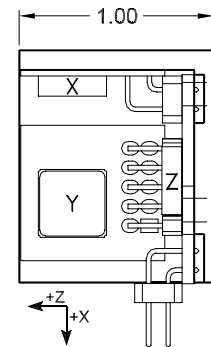
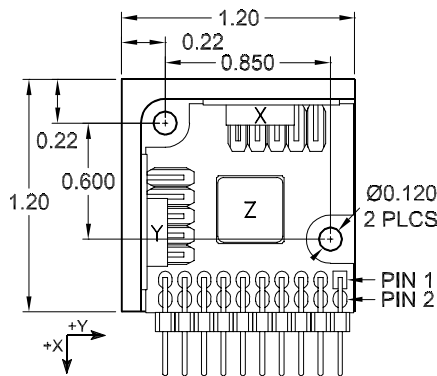

ACTUAL SIZE

Model 2412 Triaxial Analog Accelerometer Module

PIN CONNECTIONS

PIN #	PIN NAME	SIGNAL DESCRIPTION
1	-	(no connection)
3	-	(no connection)
5	-	(no connection)
7	-	(no connection)
9	AONZ	Negative Analog Output (Z-Axis)
11	GND	Shield Ground
13	AOPX	Positive Analog Output (X-Axis)
15	AONY	Negative Analog Output (Y-Axis)
17	GND	Shield Ground
19	DV	Deflection Voltage (test) input

PIN #	PIN NAME	SIGNAL DESCRIPTION
2	GND	Shield Ground
4	GND	Shield Ground
6	GND	Shield Ground
8	GND	Shield Ground
10	AOPZ	Positive Analog Output (Z-Axis)
12	AONX	Negative Analog Output (X-Axis)
14	GND	Shield Ground
16	AOPY	Positive Analog Output (Y-Axis)
18	VDD	+5 Volt DC power
20	+2.5V	2.5 Volt Reference *

* NOTE: The +2.5V reference is generated on-board and is supplied to pin 20 as a reference for single ended connections.

