

High Voltage MLC Chips

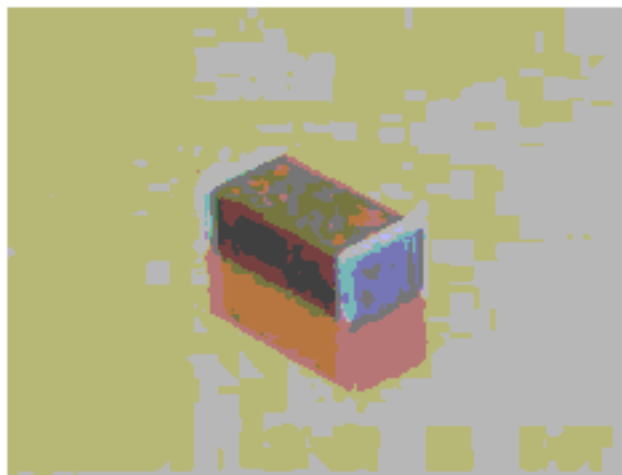

For 600V to 5000V Application



High value, low leakage and small size are difficult parameters to obtain in capacitors for high voltage systems. AVX special high voltage MLC chips capacitors meet these performance characteristics and are designed for applications such as snubbers in high frequency power converters, resonators in SMPS, and high voltage coupling/DC blocking. These high voltage chip designs exhibit low ESRs at high frequencies.

Larger physical sizes than normally encountered chips are used to make high voltage chips. These larger sizes require that special precautions be taken in applying these chips in surface mount assemblies. This is due to differences in the coefficient of thermal expansion (CTE) between the substrate materials and chip capacitors. Apply heat at less than 4°C per second during the preheat. Maximum preheat temperature must be within 50°C of the soldering temperature. The solder temperature should not exceed 230°C. Chips 1808 and larger to use reflow soldering only.

Capacitors with X7R Dielectrics are not intended for AC line filtering applications. Contact plant for recommendations.

Capacitors may require protective surface coating to prevent external arcing.

HOW TO ORDER

1808	A	A	271	K	A	1	1A
AVX Style	Voltage	Temperature Coefficient	Capacitance Code (2 significant digits + no. of zeros)	Capacitance Tolerance	Failure Rate	Termination*	Packaging/Marking**
1206	600V = C	C0G = A	Examples: 10 pF = 100 100 pF = 101 1,000 pF = 102 22,000 pF = 223 220,000 pF = 224 1 μF = 105	C0G: J = ±5% K = ±10% M = ±20% X7R: K = ±10% M = ±20% Z = +80%, -20%	A = Not Applicable	T = NiGuard Nickel Barrier Solder Plate	ME = 7" Reel Marked RE = 13" Reel Marked BE = Bulk/Marked 1A = 7" Reel Unmarked 3A = 13" Reel Unmarked 9A = Bulk/Unmarked
1210	1000V = A	X7R = C					
1808	1500V = S						
1812	2000V = G						
1825	2500V = W						
2220	3000V = H						
2225	4000V = J						
3640	5000V = K						

*Note: Leaded terminations are available. Styles 1825, 2225, & 3640 are available with "N", "L" or "J" leads as seen on page 9.
 "V" denotes uncoated leaded units similar to SMD product.
 "W" denotes leaded epoxy coated units similar to SMD product.
 IE 1825AA103KAV00J would be uncoated leaded part with "J" style leads.

**Note: Style 1808 cannot have the marking oriented in tape & reel packaging due to square cross-section of chip. Unmarked product is standard.

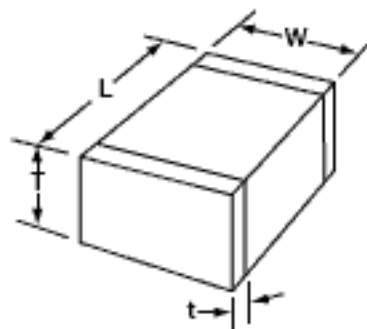

DIMENSIONS

SIZE	1206	1210	1808*	1812*	1825*	2220*	2225*	3640*
(L) Length	3.20 ± 0.2 (0.126 ± 0.008)	3.20 ± 0.2 (0.126 ± 0.008)	4.57 ± 0.25 (0.180 ± 0.010)	4.50 ± 0.3 (0.177 ± 0.012)	4.50 ± 0.3 (0.177 ± 0.012)	5.7 ± 0.4 (0.224 ± 0.016)	5.72 ± 0.25 (0.225 ± 0.010)	9.14 ± 0.25 (0.360 ± 0.010)
(W) Width	1.60 ± 0.2 (0.063 ± 0.008)	2.50 ± 0.2 (0.098 ± 0.008)	2.03 ± 0.25 (0.080 ± 0.010)	3.20 ± 0.2 (0.126 ± 0.008)	6.40 ± 0.3 (0.252 ± 0.012)	5.0 ± 0.4 (0.197 ± 0.016)	6.35 ± 0.25 (0.250 ± 0.010)	10.2 ± 0.25 (0.400 ± 0.010)
(T) Thickness Max.	1.52 (0.060)	1.70 (0.067)	2.03 (0.080)	2.54 (0.100)	2.54 (0.100)	3.3 (0.130)	2.54 (0.100)	2.54 (0.100)
(t) terminal min. max.	0.25 (0.010) 0.75 (0.030)	0.25 (0.010) 0.75 (0.030)	0.25 (0.010) 1.02 (0.040)	0.25 (0.010) 1.02 (0.040)	0.25 (0.010) 1.02 (0.040)	0.25 (0.010) 1.02 (0.040)	0.25 (0.010) 1.02 (0.040)	0.76 (0.030) 1.52 (0.060)

*Reflow Soldering Only



High Voltage MLC Chips



For 600V to 5000V Applications

C0G Dielectric

Performance Characteristics

Capacitance Range	10 pF to 0.047 μ F (25°C, 1.0 \pm 0.2 Vrms at 1kHz, for \leq 1000 pF use 1 MHz)
Capacitance Tolerances	\pm 5%, \pm 10%, \pm 20%
Dissipation Factor	0.1% max. (+25°C, 1.0 \pm 0.2 Vrms, 1 kHz, for \leq 1000 pF use 1 MHz)
Operating Temperature Range	-55°C to +125°C
Temperature Characteristic	0 \pm 30 ppm/°C (0 VDC)
Voltage Ratings	600, 1000, 1500, 2000, 2500, 3000, 4000 & 5000 VDC (+125°C)
Insulation Resistance (+25°C, at 500 VDC)	100K M Ω min. or 1000 M Ω - μ F min., whichever is less
Insulation Resistance (+125°C, at 500 VDC)	10K M Ω min. or 100 M Ω - μ F min., whichever is less
Dielectric Strength	120% rated voltage for 5 seconds at 50 mA max. current

HIGH VOLTAGE C0G CAPACITANCE VALUES

VOLTAGE		1206	1210	1808	1812	1825	2220	2225	3640
600	min.	100 pF	100 pF	100 pF	100 pF	1000 pF	1000 pF	1000 pF	1000 pF
	max.	680 pF	1500 pF	2700 pF	5600 pF	0.012 μ F	0.012 μ F	0.015 μ F	0.047 μ F
1000	min.	10 pF	100 pF	100 pF	100 pF	100 pF	1000 pF	1000 pF	1000 pF
	max.	470 pF	820 pF	1500 pF	2700 pF	6800 pF	0.010 μ F	0.010 μ F	0.018 μ F
1500	min.	10 pF	100 pF	10 pF	10 pF	100 pF	1000 pF	1000 pF	100 pF
	max.	150 pF	330 pF	470 pF	1000 pF	2700 pF	2700 pF	3300 pF	8200 pF
2000	min.	10 pF	10 pF	10 pF	10 pF	100 pF	1000 pF	1000 pF	100 pF
	max.	68 pF	150 pF	270 pF	680 pF	1800 pF	2200 pF	2200 pF	5600 pF
2500	min.	—	—	10 pF	10 pF	10 pF	100 pF	100 pF	100 pF
	max.	—	—	150 pF	390 pF	1000 pF	1000 pF	1200 pF	3900 pF
3000	min.	—	—	10 pF	10 pF	10 pF	10 pF	10 pF	100 pF
	max.	—	—	100 pF	330 pF	680 pF	680 pF	820 pF	2200 pF
4000	min.	—	—	10 pF	10 pF	10 pF	10 pF	10 pF	100 pF
	max.	—	—	39 pF	100 pF	220 pF	220 pF	330 pF	1000 pF
5000	min.	—	—	—	—	—	—	—	10 pF
	max.	—	—	—	—	—	—	—	680 pF

X7R Dielectric

Performance Characteristics

Capacitance Range	10 pF to 0.56 μ F (25°C, 1.0 \pm 0.2 Vrms at 1kHz)
Capacitance Tolerances	\pm 10%; \pm 20%; +80%, -20%
Dissipation Factor	2.5% max. (+25°C, 1.0 \pm 0.2 Vrms, 1 kHz)
Operating Temperature Range	-55°C to +125°C
Temperature Characteristic	\pm 15% (0 VDC)
Voltage Ratings	600, 1000, 1500, 2000, 2500, 3000, 4000 & 5000 VDC (+125°C)
Insulation Resistance (+25°C, at 500 VDC)	100K M Ω min. or 1000 M Ω - μ F min., whichever is less
Insulation Resistance (+125°C, at 500 VDC)	10K M Ω min. or 100 M Ω - μ F min., whichever is less
Dielectric Strength	120% rated voltage for 5 seconds at 50 mA max. current

HIGH VOLTAGE X7R MAXIMUM CAPACITANCE VALUES

VOLTAGE		1206	1210	1808	1812	1825	2220	2225	3640
600	min.	1000 pF	1000 pF	.01 μ F	.01 μ F	.01 μ F	.01 μ F	.01 μ F	.01 μ F
	max.	0.015 μ F	0.027 μ F	0.033 μ F	0.068 μ F	0.15 μ F	0.15 μ F	0.22 μ F	0.56 μ F
1000	min.	1000 pF	1000 pF	1000 pF	1000 pF	1000 pF	.01 μ F	.01 μ F	.01 μ F
	max.	4700 pF	0.010 μ F	0.015 μ F	0.027 μ F	0.068 μ F	0.068 μ F	0.082 μ F	0.22 μ F
1500	min.	100 pF	100 pF	100 pF	100 pF	1000 pF	1000 pF	1000 pF	.01 μ F
	max.	1200 pF	2700 pF	3900 pF	8200 pF	0.018 μ F	0.022 μ F	0.027 μ F	0.068 μ F
2000	min.	10 pF	100 pF	100 pF	100 pF	100 pF	1000 pF	1000 pF	1000 pF
	max.	470 pF	1000 pF	1800 pF	4700 pF	8200 pF	0.010 μ F	0.012 μ F	0.027 μ F
2500	min.	—	—	10 pF	10 pF	100 pF	1000 pF	1000 pF	1000 pF
	max.	—	—	1200 pF	2200 pF	5600 pF	6800 pF	8200 pF	0.022 μ F
3000	min.	—	—	10 pF	10 pF	100 pF	1000 pF	1000 pF	1000 pF
	max.	—	—	560 pF	1200 pF	2700 pF	3300 pF	4700 pF	0.018 μ F
4000	min.	—	—	—	—	—	—	—	100 pF
	max.	—	—	—	—	—	—	—	6800 pF
5000	min.	—	—	—	—	—	—	—	100 pF
	max.	—	—	—	—	—	—	—	3300 pF