



MX23C6410

64M-BIT Mask ROM (8/16 Bit Output)
For SOP and TSOP Packages

FEATURES

- Bit organization
 - 8M x 8 (byte mode)
 - 4M x 16 (word mode)
- Fast access time
 - Random access: 100ns (max.)
- Current
 - Operating: 70mA
 - Standby: 100uA (max.)
- Supply voltage
 - 5V±10%
- Package
 - 44 pin SOP (500 mil)
 - 48 pin TSOP (12mm x 20mm)

ORDER INFORMATION

Part No.	Access Time	Package
MX23C6410MC-10	100ns	44 pin SOP
MX23C6410MC-12	120ns	44 pin SOP
MX23C6410MC-15	150ns	44 pin SOP
MX23C6410TC-10	100ns	48 pin TSOP
MX23C6410TC-12	120ns	48 pin TSOP
MX23C6410TC-15	150ns	48 pin TSOP
MX23C6410RC-10	100ns	48 pin TSOP (Reverse type)
MX23C6410RC-12	120ns	48 pin TSOP (Reverse type)
MX23C6410RC-15	150ns	48 pin TSOP (Reverse type)

PIN CONFIGURATION

44 SOP

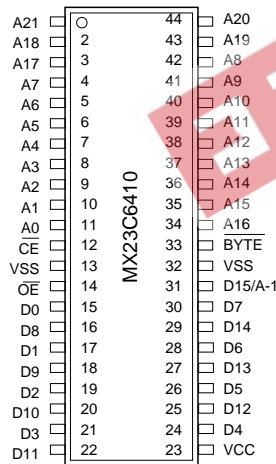

48 TSOP (NORMAL TYPE)

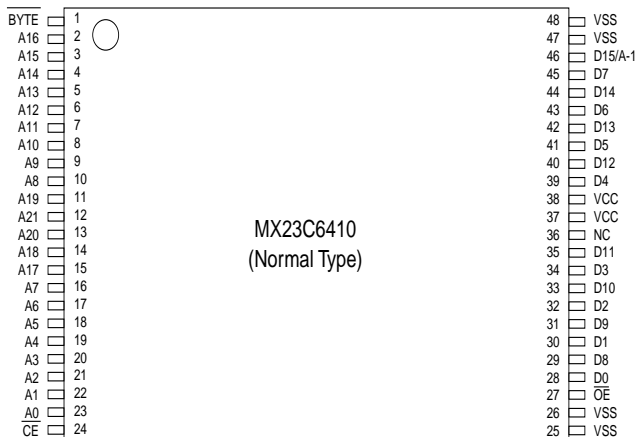

48 TSOP (REVERSE TYPE)

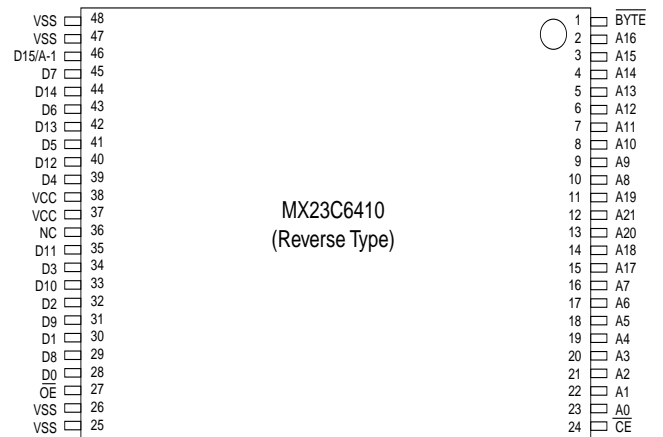

PIN DESCRIPTION

Symbol	Pin Function
A0~A21	Address Inputs
D0~D14	Data Outputs
D15/A-1	D15 (Word Mode) / LSB Address (Byte Mode)
\overline{CE}	Chip Enable Input
\overline{OE}	Output Enable Input
\overline{Byte}	Word / Byte Mode Selection
VCC	Power Supply Pin
VSS	Ground Pin
NC	No Connection

MODE SELECTION

\overline{CE}	\overline{OE}	\overline{Byte}	D15/A-1	D0~D7	D8~D15	Mode	Power
H	X	X	X	High Z	High Z	-	Stand-by
L	H	X	X	High Z	High Z	-	Active
L	L	H	Output	D0~D7	D8~D15	Word	Active
L	L	L	Input	D0~D7	High Z	Byte	Active

BLOCK DIAGRAM

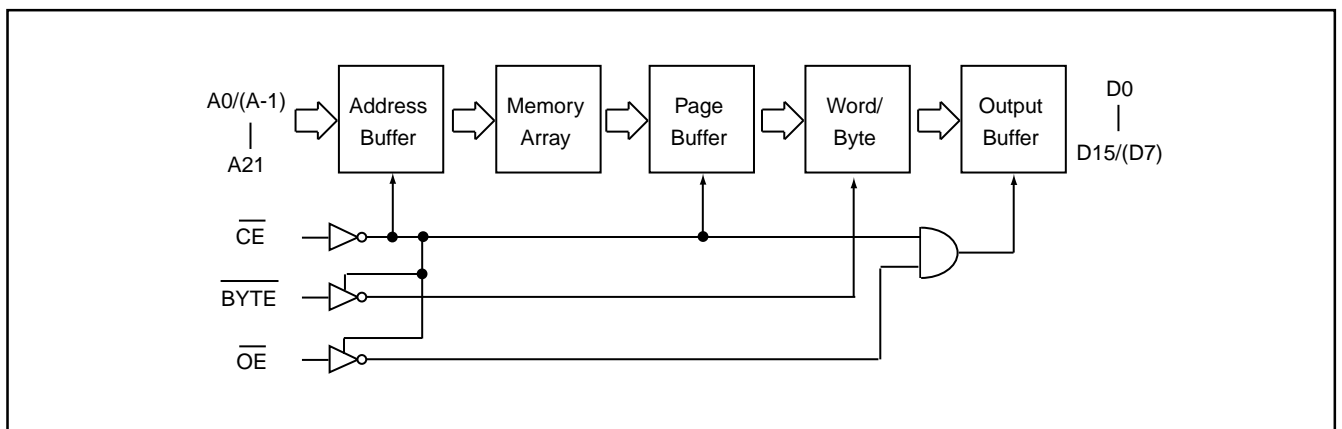

ABSOLUTE MAXIMUM RATINGS

Item	Symbol	Ratings
Voltage on any Pin Relative to VSS	VIN	-0.8V to VCC+2.0V (Note)
Ambient Operating Temperature	Topr	0°C to 70°C
Storage Temperature	Tstg	-65°C to 125°C

Note: Minimum DC voltage on input or I/O pins is -0.5V. During voltage transitions, inputs may undershoot VSS to -0.8V for periods of up to 20ns. Maximum DC voltage on input or I/O pins is VCC+0.5V. During voltage transitions, input may overshoot VCC to VCC+2.0V for periods of up to 20ns.

DC CHARACTERISTICS (Ta = 0°C ~ 70°C, VCC = 5V±10%)

Item	Symbol	MIN.	MAX.	Conditions
Output High Voltage	VOH	2.4V		IOH = -1.0mA
Output Low Voltage	VOL	-	0.4V	IOL = 2.1mA
Input High Voltage	VIH	2.2V	VCC+0.3V	
Input Low Voltage	VIL	-0.3V	0.8V	
Input Leakage Current	ILI	-	5uA	0V, VCC
Output Leakage Current	ILO	-	5uA	0V, VCC
Operating Current	ICC1	-	70mA	f=5MHz, all output open
Standby Current (TTL)	ISTB1	-	1mA	CE = VIH
Standby Current (cmos)	ISTB2	-	100uA	CE > VCC-0.2V
Input Capacitance	CIN	-	10pF	Ta = 25°C, f = 1MHZ
Output Capacitance	COUT	-	10pF	Ta = 25°C, f = 1MHZ

AC CHARACTERISTICS (Ta = 0°C ~ 70°C, VCC = 5V±10%)

Item	Symbol	23C6410-10		23C6410-12		23C6410-15	
		MIN.	MAX.	MIN.	MAX.	MIN.	MAX.
Read Cycle Time	tRC	100ns	-	120ns	-	150ns	-
Address Access Time	tAA	-	100ns	-	120ns	-	150ns
Chip Enable Access Time	tACE	-	100ns	-	120ns	-	150ns
Output Enable Time	tOE	-	50ns	-	60ns	-	70ns
Output Hold After Address	tOH	0ns	-	0ns	-	0ns	-
Output High Z Delay	tHZ	-	20ns	-	20ns	-	20ns

Note: Output high-impedance delay (tHZ) is measured from OE or CE going high, and this parameter guaranteed by design over the full voltage and temperature operating range - not tested.

AC Test Conditions

Input Pulse Levels	0.4V~ 2.4V
Input Rise and Fall Times	10ns
Input Timing Level	1.4V
Output Timing Level	0.8V and 2.0V
Output Load	See Figure

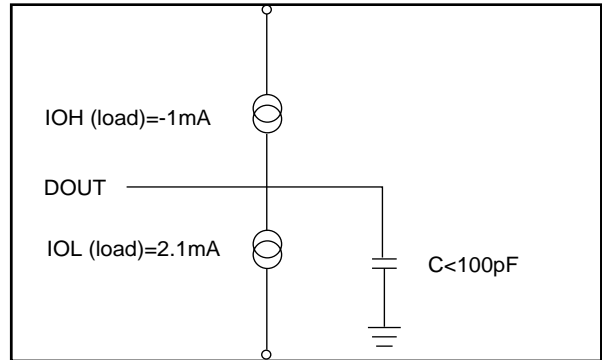

Note: No output loading is present in tester load board.

Active loading is used and under software programming control.

Output loading capacitance includes load board's and all stray capacitance.

TIMING DIAGRAM

RANDOM READ

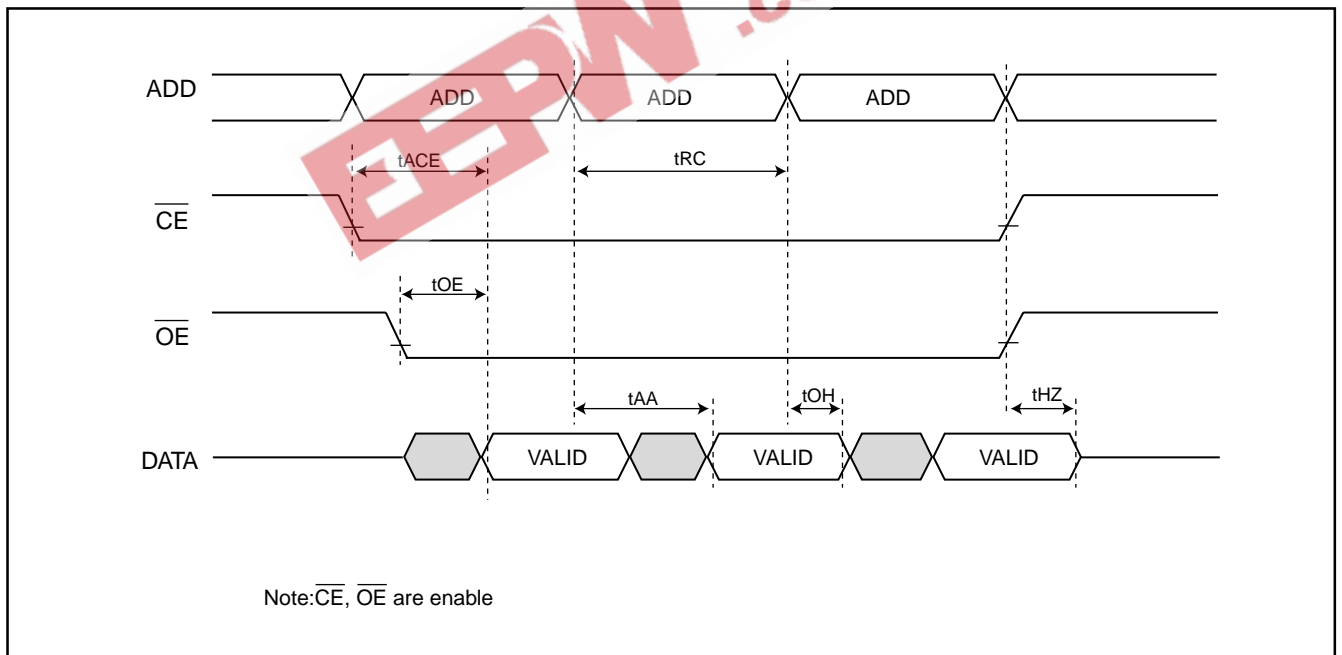

PACKAGE INFORMATION

44-PIN PLASTIC SOP

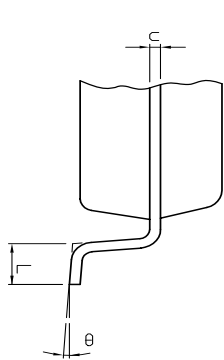
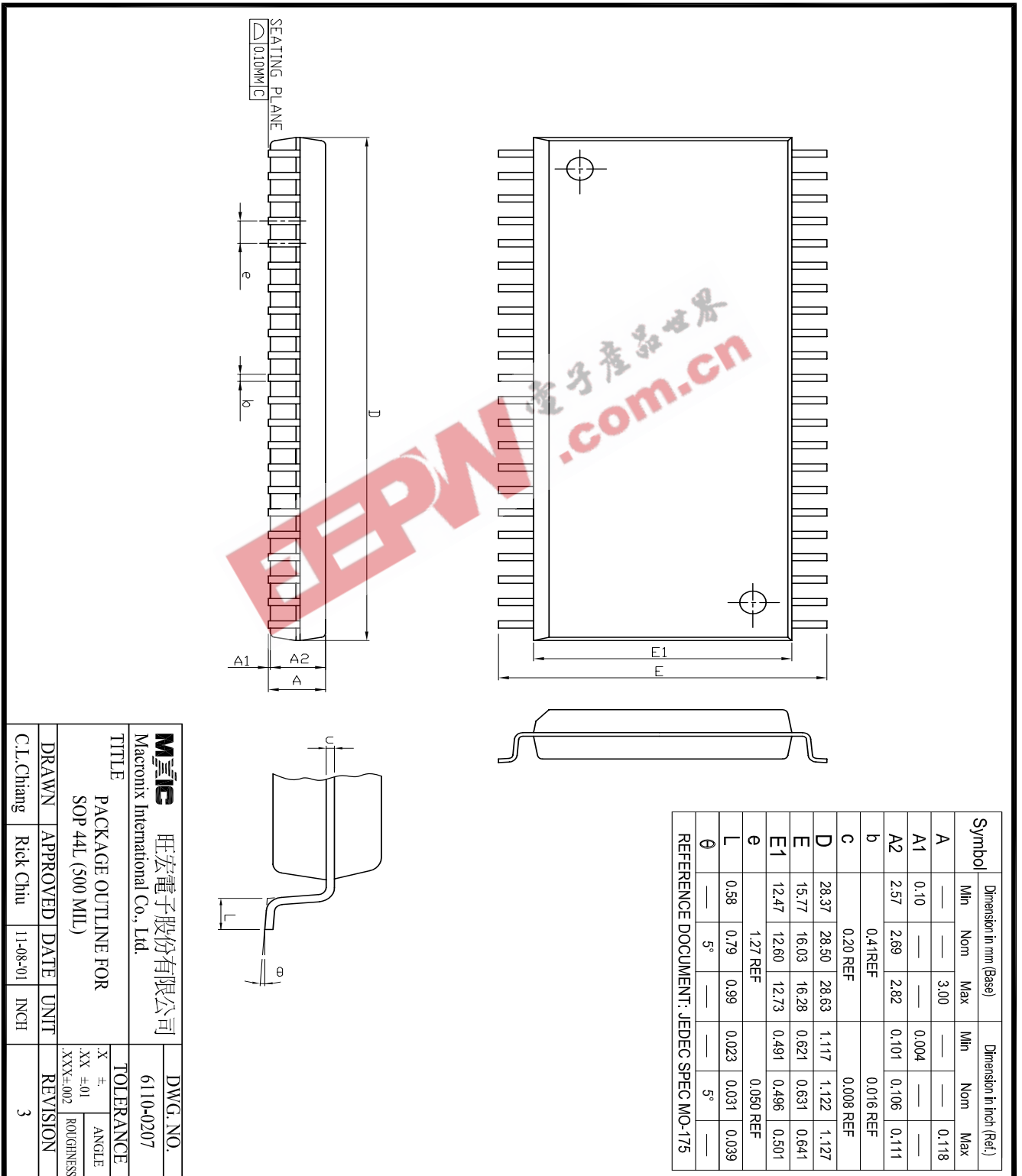

旺宏電子股份有限公司 Macronix International Co., Ltd.		DWG. NO.	6110-0207
TITLE		TOLERANCE	
PACKAGE OUTLINE FOR		X ±	—
SOP 44L (500 MIL)		XX ±01	ANGLE
DRAWN		.XXX±002	ROUGHNESS
APPROVED	DATE	UNIT	REVISION
Rick Chiu	11-08-01	INCH	3

48-PIN PLASTIC TSOP

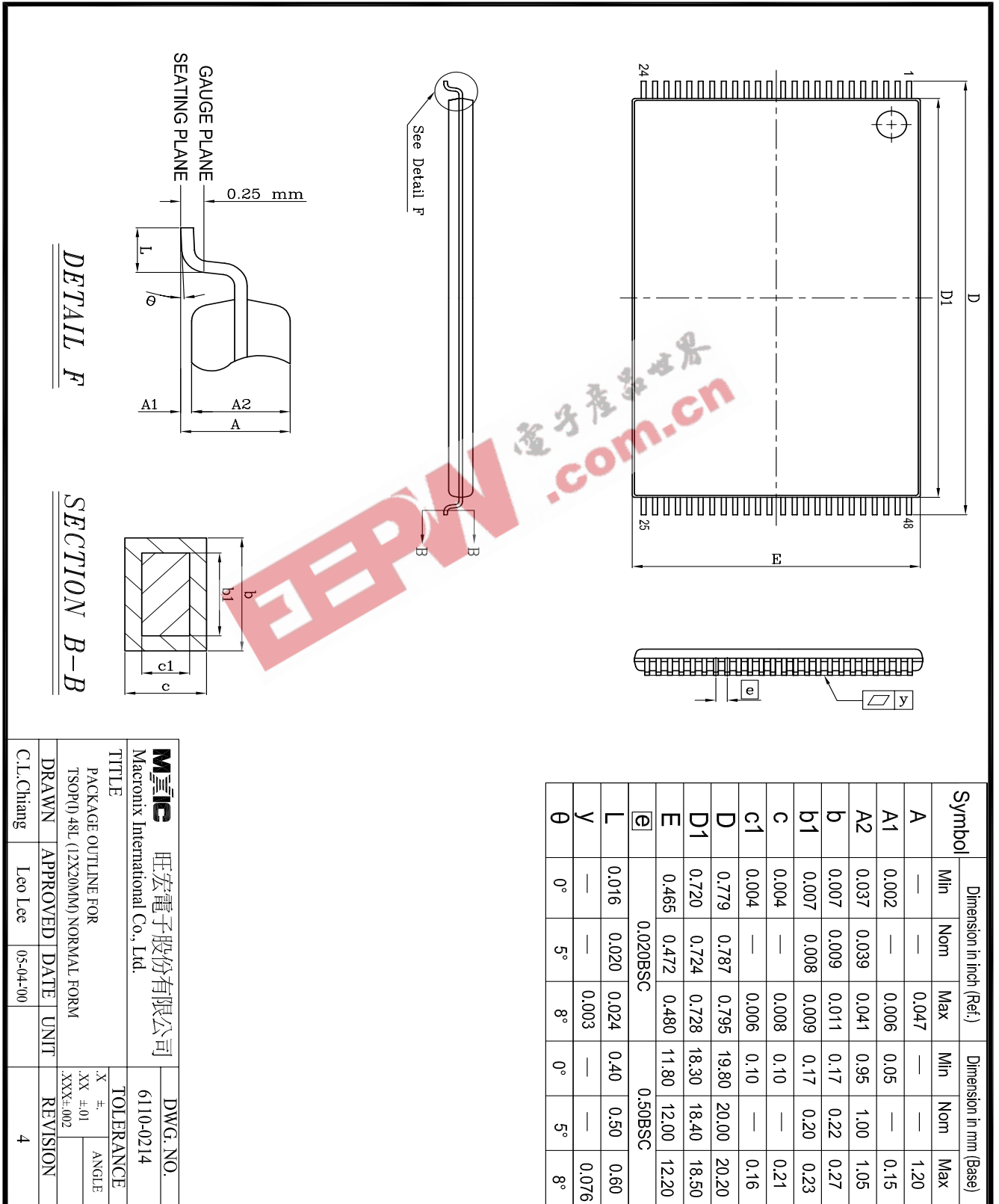

DETAIL F

SECTION B-B

MIIIC 旺宏電子股份有限公司 Macronix International Co., Ltd.		DWG. NO. 6110-0214	
TITLE PACKAGE OUTLINE FOR TSOP0.48L (12X20MM) NORMAL FORM			
DRAWN	APPROVED	DATE	UNIT
C.L.Chiang	Leo Lee	05-04-00	
TOLERANCE		REVISION	
X ±	XX ±0.1	ANGLE	
.XXX±0.02		4	



REVISION HISTORY

Revision	Description	Page	Date
2.1	AC Characteristics: tOH 10ns --> 0ns	P3	FEB/01/1999
2.2	Add Order Information--Note:MX23C6410PC-10 only applies to supply voltage 5V±5%	P1	OCT/02/2000
2.3	Modify Package Information	P5,6,7	OCT/09/2000
2.4	Modify Operating Current:100mA-->70mA	P1,3	JAN/15/2001
2.5	Modify Package Information Added 44-pin TSOP package	P5~7 P1,8	JUL/17/2001
2.6	Move 42-pin PDIP Package to another new data sheet	P1,5	JUL/20/2001
2.7	Removed 44-pin TSOP Package	P1,7	JAN/15/2002





MX23C6410

EEPW 电子产品世界 .com.cn

MACRONIX INTERNATIONAL Co., LTD.

HEADQUARTERS:

TEL:+886-3-578-6688

FAX:+886-3-563-2888

EUROPE OFFICE:

TEL:+32-2-456-8020

FAX:+32-2-456-8021

JAPAN OFFICE:

TEL:+81-44-246-9100

FAX:+81-44-246-9105

SINGAPORE OFFICE:

TEL:+65-348-8385

FAX:+65-348-8096

TAIPEI OFFICE:

TEL:+886-2-2509-3300

FAX:+886-2-2509-2200

MACRONIX AMERICA, INC.

TEL:+1-408-453-8088

FAX:+1-408-453-8488

CHICAGO OFFICE:

TEL:+1-847-963-1900

FAX:+1-847-963-1909

[http : //www.macronix.com](http://www.macronix.com)