

ECM Surface Mount Crystal

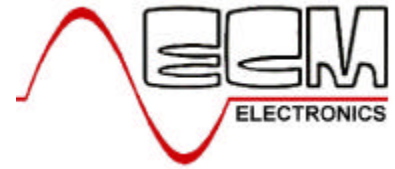

ECM 200SMX

- Molded Plastic Package
- Small Footprint
- Excellent Shock and Heat Resistance
- Tape & Reel or Bulk Packaging



Parameter	200SMX	
Frequency Range	32.768kHz and 24kHz to 615kHz	Fund
Calibration Tolerance @25°C	+/- 50ppm standard others available	Specify
Temperature Tolerance	+/- 50ppm standard others available	Specify
Operating Temperature	-40°C to +85°C other options available	Specify
Storage Temp	-55°C to +125°C	
Load Capacitance	6pF to 12.5pF	Specify
ESR	20kΩ to 50kΩ Frequency Dependant	
Shunt Capacitance	1.0pf max	
Drive Level	0.1mW max	
Ageing	+/- 5ppm First Year	

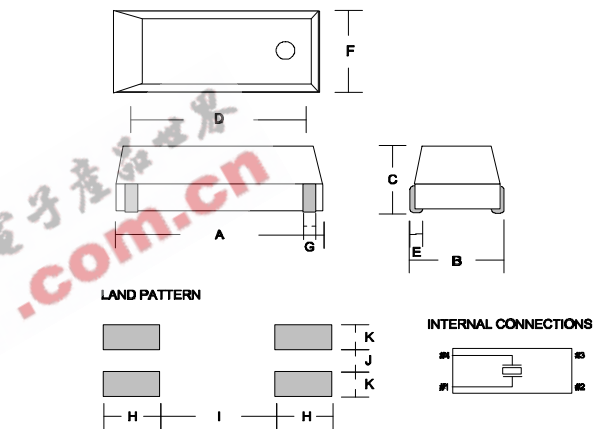

Standard Frequencies in kHz.

24.000	75.000	106.000
26.667	76.800	130.000
31.200	77.025	131.072
32.000	77.040	150.000
32.768	77.056	153.600
38.000	77.500	200.000
38.400	96.000	307.200
40.000	99.660	614.400
65.536	100.000	

A	B	C	D	E	F
8.70	3.70	2.50	5.50	1.40	2.90

G	H	I	J	K
0.60	0.70	4.80	0.70	1.60

Dimensions in mm

ECM Electronics Limited, Penmaen House, Ashington, West Sussex, RH20 3JR, UK
Tel: +44(0)1903 892810: Fax: +44(0)1903 892738. Email: ecm@ecmelectronics.co.uk

Although we have attempted to accurately reflect the products we market. ECM reserve the right without prior notice to discontinue any product or make design changes we believe necessary.