



# 2.5 V to 5.5 V, 230 $\mu$ A, Parallel Interface Dual Voltage-Output 8-/10-/12-Bit DACs

## AD5332/AD5333/AD5342/AD5343\*

### FEATURES

- AD5332: Dual 8-Bit DAC in 20-Lead TSSOP
- AD5333: Dual 10-Bit DAC in 24-Lead TSSOP
- AD5342: Dual 12-Bit DAC in 28-Lead TSSOP
- AD5343: Dual 12-Bit DAC in 20-Lead TSSOP
- Low Power Operation: 230  $\mu$ A @ 3 V, 300  $\mu$ A @ 5 V via  $\overline{\text{PD}}$  Pin
- Power-Down to 80 nA @ 3 V, 200 nA @ 5 V
- 2.5 V to 5.5 V Power Supply
- Double-Buffered Input Logic
- Guaranteed Monotonic by Design Over All Codes
- Buffered/Unbuffered Reference Input Options
- Output Range: 0- $V_{\text{REF}}$  or 0-2  $V_{\text{REF}}$
- Power-On Reset to Zero Volts
- Simultaneous Update of DAC Outputs via  $\overline{\text{LDAC}}$  Pin
- Asynchronous  $\overline{\text{CLR}}$  Facility
- Low Power Parallel Data Interface
- On-Chip Rail-to-Rail Output Buffer Amplifiers
- Temperature Range: -40°C to +105°C

### APPLICATIONS

- Portable Battery-Powered Instruments
- Digital Gain and Offset Adjustment
- Programmable Voltage and Current Sources
- Programmable Attenuators
- Industrial Process Control

### GENERAL DESCRIPTION

The AD5332/AD5333/AD5342/AD5343 are dual 8-, 10-, and 12-bit DACs. They operate from a 2.5 V to 5.5 V supply consuming just 230  $\mu$ A at 3 V, and feature a power-down pin,  $\overline{\text{PD}}$  that further reduces the current to 80 nA. These devices incorporate an on-chip output buffer that can drive the output to both supply rails, while the AD5333 and AD5342 allow a choice of buffered or unbuffered reference input.

The AD5332/AD5333/AD5342/AD5343 have a parallel interface.  $\overline{\text{CS}}$  selects the device and data is loaded into the input registers on the rising edge of  $\overline{\text{WR}}$ .

The GAIN pin on the AD5333 and AD5342 allows the output range to be set at 0 V to  $V_{\text{REF}}$  or 0 V to  $2 \times V_{\text{REF}}$ .

Input data to the DACs is double-buffered, allowing simultaneous update of multiple DACs in a system using the  $\overline{\text{LDAC}}$  pin.

An asynchronous  $\overline{\text{CLR}}$  input is also provided, which resets the contents of the Input Register and the DAC Register to all zeros. These devices also incorporate a power-on reset circuit that ensures that the DAC output powers on to 0 V and remains there until valid data is written to the device.

The AD5332/AD5333/AD5342/AD5343 are available in Thin Shrink Small Outline Packages (TSSOP).

AD5332 FUNCTIONAL BLOCK DIAGRAM  
(Other Diagrams Inside)

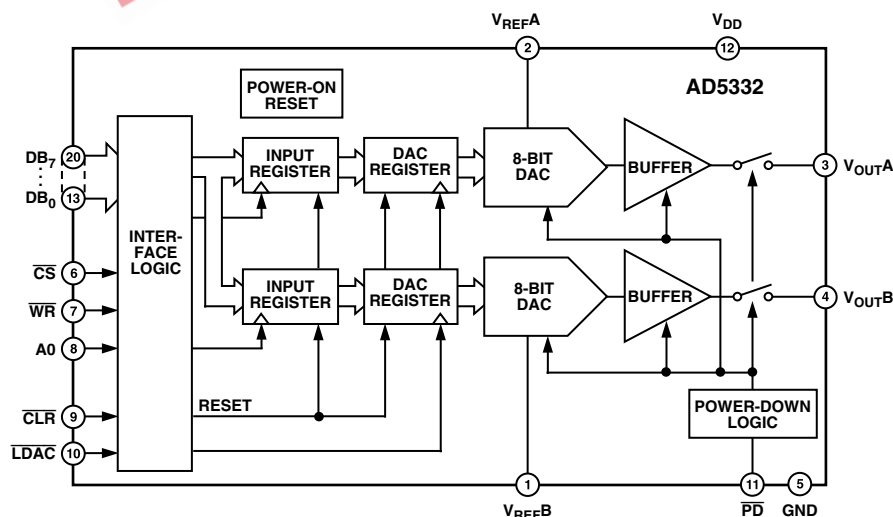

\*Protected by U.S. Patent Number 5,969,657; other patents pending.

REV. 0

Information furnished by Analog Devices is believed to be accurate and reliable. However, no responsibility is assumed by Analog Devices for its use, nor for any infringements of patents or other rights of third parties which may result from its use. No license is granted by implication or otherwise under any patent or patent rights of Analog Devices.

One Technology Way, P.O. Box 9106, Norwood, MA 02062-9106, U.S.A.  
Tel: 781/329-4700 World Wide Web Site: <http://www.analog.com>  
Fax: 781/326-8703 © Analog Devices, Inc., 2000

# AD5332/AD5333/AD5342/AD5343—SPECIFICATIONS

( $V_{DD} = 2.5\text{ V to }5.5\text{ V}$ ,  $V_{REF} = 2\text{ V}$ ,  $R_L = 2\text{ k}\Omega$  to GND;  $C_L = 200\text{ pF}$  to GND; all specifications  $T_{MIN}$  to  $T_{MAX}$  unless otherwise noted.)

Parameter <sup>1</sup>	B Version <sup>2</sup>			Unit	Conditions/Comments
	Min	Typ	Max		
<b>DC PERFORMANCE<sup>3, 4</sup></b>					
AD5332					
Resolution		8		Bits	Guaranteed Monotonic By Design Over All Codes
Relative Accuracy		$\pm 0.15$	$\pm 1$	LSB	
Differential Nonlinearity		$\pm 0.02$	$\pm 0.25$	LSB	
AD5333					
Resolution		10		Bits	Guaranteed Monotonic By Design Over All Codes
Relative Accuracy		$\pm 0.5$	$\pm 4$	LSB	
Differential Nonlinearity		$\pm 0.05$	$\pm 0.5$	LSB	
AD5342/AD5343					
Resolution		12		Bits	Guaranteed Monotonic By Design Over All Codes
Relative Accuracy		$\pm 2$	$\pm 16$	LSB	
Differential Nonlinearity		$\pm 0.2$	$\pm 1$	LSB	
Offset Error		$\pm 0.4$	$\pm 3$	% of FSR	Lower Deadband Exists Only if Offset Error Is Negative $V_{DD} = 5\text{ V}$ . Upper Deadband Exists Only if $V_{REF} = V_{DD}$
Gain Error		$\pm 0.15$	$\pm 1$	% of FSR	
Lower Deadband <sup>5</sup>		10	60	mV	
Upper Deadband		10	60	mV	
Offset Error Drift <sup>6</sup>		-12		ppm of FSR/ $^{\circ}\text{C}$	
Gain Error Drift <sup>6</sup>		-5		ppm of FSR/ $^{\circ}\text{C}$	
DC Power Supply Rejection Ratio <sup>6</sup>		-60		dB	$\Delta V_{DD} = \pm 10\%$ $R_L = 2\text{ k}\Omega$ to GND, $2\text{ k}\Omega$ to $V_{DD}$ ; $C_L = 200\text{ pF}$ to GND; Gain = 0
DC Crosstalk <sup>6</sup>		200		$\mu\text{V}$	
<b>DAC REFERENCE INPUT<sup>6</sup></b>					
$V_{REF}$ Input Range	1 0.25		$V_{DD}$ $V_{DD}$	V V	Buffered Reference (AD5333 and AD5342) Unbuffered Reference
$V_{REF}$ Input Impedance		>10 180 90		M $\Omega$ k $\Omega$ k $\Omega$	Buffered Reference (AD5333 and AD5342) Unbuffered Reference. Gain = 1, Input Impedance = $R_{DAC}$ Unbuffered Reference. Gain = 2, Input Impedance = $R_{DAC}$
Reference Feedthrough		-90		dB	Frequency = 10 kHz
Channel-to-Channel Isolation		-90		dB	Frequency = 10 kHz (AD5332, AD5333, and AD5342)
<b>OUTPUT CHARACTERISTICS<sup>6</sup></b>					
Minimum Output Voltage <sup>4, 7</sup>		0.001		V min	Rail-to-Rail Operation
Maximum Output Voltage <sup>4, 7</sup>		$V_{DD} - 0.001$		V max	
DC Output Impedance		0.5		$\Omega$	$V_{DD} = 5\text{ V}$ $V_{DD} = 3\text{ V}$
Short Circuit Current		25		mA	
		16		mA	
Power-Up Time		2.5		$\mu\text{s}$	Coming Out of Power-Down Mode. $V_{DD} = 5\text{ V}$
		5		$\mu\text{s}$	Coming Out of Power-Down Mode. $V_{DD} = 3\text{ V}$
<b>LOGIC INPUTS<sup>6</sup></b>					
Input Current		$\pm 1$		$\mu\text{A}$	$V_{DD} = 5\text{ V} \pm 10\%$ $V_{DD} = 3\text{ V} \pm 10\%$ $V_{DD} = 2.5\text{ V}$
$V_{IL}$ , Input Low Voltage			0.8 0.6 0.5	V V V	
$V_{IH}$ , Input High Voltage	2.4 2.1 2.0			V V V	
Pin Capacitance		3.5		pF	$V_{DD} = 2.5\text{ V}$
<b>POWER REQUIREMENTS</b>					
$V_{DD}$	2.5		5.5	V	All DACs active and excluding load currents Unbuffered Reference. $V_{IH} = V_{DD}$ , $V_{IL} = \text{GND}$ . $I_{DD}$ increases by $50\text{ }\mu\text{A}$ at $V_{REF} > V_{DD} - 100\text{ mV}$ . In Buffered Mode extra current is $(5 + V_{REF}/R_{DAC})\text{ }\mu\text{A}$ .
$I_{DD}$ (Normal Mode)					
$V_{DD} = 4.5\text{ V to }5.5\text{ V}$		300	450	$\mu\text{A}$	
$V_{DD} = 2.5\text{ V to }3.6\text{ V}$		230	350	$\mu\text{A}$	
$I_{DD}$ (Power-Down Mode)					
$V_{DD} = 4.5\text{ V to }5.5\text{ V}$		0.2	1	$\mu\text{A}$	
$V_{DD} = 2.5\text{ V to }3.6\text{ V}$		0.08	1	$\mu\text{A}$	

## NOTES

<sup>1</sup>See Terminology section.

<sup>2</sup>Temperature range: B Version:  $-40^{\circ}\text{C}$  to  $+105^{\circ}\text{C}$ ; typical specifications are at  $25^{\circ}\text{C}$ .

<sup>3</sup>Linearity is tested using a reduced code range: AD5332 (Code 8 to 255); AD5333 (Code 28 to 1023); AD5342/AD5343 (Code 115 to 4095).

<sup>4</sup>DC specifications tested with outputs unloaded.

<sup>5</sup>This corresponds to x codes. x = Deadband voltage/LSB size.

<sup>6</sup>Guaranteed by design and characterization, not production tested.

<sup>7</sup>In order for the amplifier output to reach its minimum voltage, Offset Error must be negative. In order for the amplifier output to reach its maximum voltage,  $V_{REF} = V_{DD}$  and "Offset plus Gain" Error must be positive.

Specifications subject to change without notice.

# AD5332/AD5333/AD5342/AD5343

## AC CHARACTERISTICS<sup>1</sup> ( $V_{DD} = 2.5\text{ V to }5.5\text{ V}$ , $R_L = 2\text{ k}\Omega\text{ to GND}$ ; $C_L = 200\text{ pF to GND}$ ; all specifications $T_{MIN}$ to $T_{MAX}$ unless otherwise noted.)

Parameter <sup>2</sup>	B Version <sup>3</sup>			Unit	Conditions/Comments
	Min	Typ	Max		
Output Voltage Settling Time					$V_{REF} = 2\text{ V}$ . See Figure 20
AD5332		6	8	$\mu\text{s}$	1/4 Scale to 3/4 Scale Change (40 H to C0 H)
AD5333		7	9	$\mu\text{s}$	1/4 Scale to 3/4 Scale Change (100 H to 300 H)
AD5342		8	10	$\mu\text{s}$	1/4 Scale to 3/4 Scale Change (400 H to C00 H)
AD5343		8	10	$\mu\text{s}$	1/4 Scale to 3/4 Scale Change (400 H to C00 H)
Slew Rate		0.7		$\text{V}/\mu\text{s}$	
Major Code Transition Glitch Energy		6		$\text{nV}\cdot\text{s}$	1 LSB Change Around Major Carry
Digital Feedthrough		0.5		$\text{nV}\cdot\text{s}$	
Digital Crosstalk		3		$\text{nV}\cdot\text{s}$	
Analog Crosstalk		0.5		$\text{nV}\cdot\text{s}$	
DAC-to-DAC Crosstalk		3.5		$\text{nV}\cdot\text{s}$	
Multiplying Bandwidth		200		$\text{kHz}$	$V_{REF} = 2\text{ V} \pm 0.1\text{ V p-p}$ . Unbuffered Mode
Total Harmonic Distortion		-70		$\text{dB}$	$V_{REF} = 2.5\text{ V} \pm 0.1\text{ V p-p}$ . Frequency = 10 kHz

### NOTES

<sup>1</sup>Guaranteed by design and characterization, not production tested.

<sup>2</sup>See Terminology section.

<sup>3</sup>Temperature range: B Version:  $-40^\circ\text{C}$  to  $+105^\circ\text{C}$ ; typical specifications are at  $25^\circ\text{C}$ .

Specifications subject to change without notice.

## TIMING CHARACTERISTICS<sup>1, 2, 3</sup> ( $V_{DD} = 2.5\text{ V to }5.5\text{ V}$ , All specifications $T_{MIN}$ to $T_{MAX}$ unless otherwise noted.)

Parameter	Limit at $T_{MIN}$ , $T_{MAX}$	Unit	Condition/Comments
$t_1$	0	ns min	$\overline{\text{CS}}$ to $\overline{\text{WR}}$ Setup Time
$t_2$	0	ns min	$\overline{\text{CS}}$ to $\overline{\text{WR}}$ Hold Time
$t_3$	20	ns min	$\overline{\text{WR}}$ Pulsewidth
$t_4$	5	ns min	Data, GAIN, BUF, HBEN Setup Time
$t_5$	4.5	ns min	Data, GAIN, BUF, HBEN Hold Time
$t_6$	5	ns min	Synchronous Mode. $\overline{\text{WR}}$ Falling to $\overline{\text{LDAC}}$ Falling
$t_7$	5	ns min	Synchronous Mode. $\overline{\text{LDAC}}$ Falling to $\overline{\text{WR}}$ Rising
$t_8$	4.5	ns min	Synchronous Mode. $\overline{\text{WR}}$ Rising to $\overline{\text{LDAC}}$ Rising
$t_9$	5	ns min	Asynchronous Mode. $\overline{\text{LDAC}}$ Rising to $\overline{\text{WR}}$ Rising
$t_{10}$	4.5	ns min	Asynchronous Mode. $\overline{\text{WR}}$ Rising to $\overline{\text{LDAC}}$ Falling
$t_{11}$	20	ns min	$\overline{\text{LDAC}}$ Pulsewidth
$t_{12}$	20	ns min	$\overline{\text{CLR}}$ Pulsewidth
$t_{13}$	50	ns min	Time Between $\overline{\text{WR}}$ Cycles
$t_{14}$	20	ns min	A0 Setup Time
$t_{15}$	0	ns min	A0 Hold Time

### NOTES

<sup>1</sup>Guaranteed by design and characterization, not production tested.

<sup>2</sup>All input signals are specified with  $t_r = t_f = 5\text{ ns}$  (10% to 90% of  $V_{DD}$ ) and timed from a voltage level of  $(V_{IL} + V_{IH})/2$ .

<sup>3</sup>See Figure 1.

Specifications subject to change without notice.

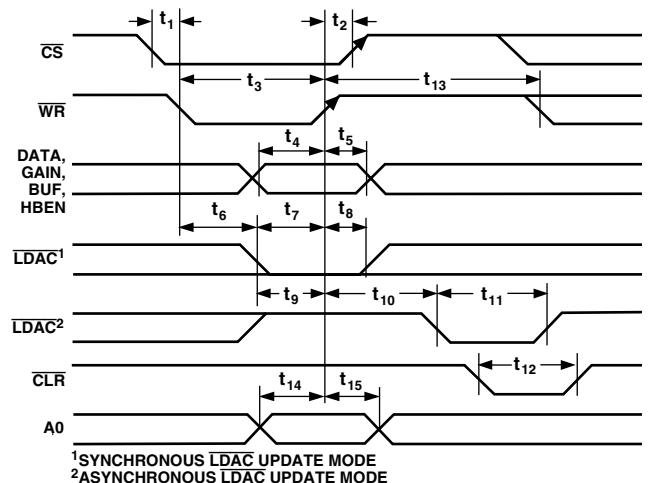

Figure 1. Parallel Interface Timing Diagram

# AD5332/AD5333/AD5342/AD5343

## ABSOLUTE MAXIMUM RATINGS\*

(T<sub>A</sub> = 25°C unless otherwise noted)

V <sub>DD</sub> to GND	−0.3 V to +7 V
Digital Input Voltage to GND	−0.3 V to V <sub>DD</sub> + 0.3 V
Digital Output Voltage to GND	−0.3 V to V <sub>DD</sub> + 0.3 V
Reference Input Voltage to GND	−0.3 V to V <sub>DD</sub> + 0.3 V
V <sub>OUT</sub> to GND	−0.3 V to V <sub>DD</sub> + 0.3 V
Operating Temperature Range	
Industrial (B Version)	−40°C to +105°C
Storage Temperature Range	−65°C to +150°C
Junction Temperature	150°C
TSSOP Package	
Power Dissipation	(T <sub>J max</sub> − T <sub>A</sub> )/θ <sub>JA</sub> mW
θ <sub>JA</sub> Thermal Impedance (20-Lead TSSOP)	143°C/W

θ <sub>JA</sub> Thermal Impedance (24-Lead TSSOP)	128°C/W
θ <sub>JA</sub> Thermal Impedance (28-Lead TSSOP)	97.9°C/W
θ <sub>JC</sub> Thermal Impedance (20-Lead TSSOP)	45°C/W
θ <sub>JC</sub> Thermal Impedance (24-Lead TSSOP)	42°C/W
θ <sub>JC</sub> Thermal Impedance (28-Lead TSSOP)	14°C/W
Reflow Soldering	
Peak Temperature	220 +5/−0°C
Time at Peak Temperature	10 sec to 40 sec

\*Stresses above those listed under Absolute Maximum Ratings may cause permanent damage to the device. This is a stress rating only; functional operation of the device at these or any other conditions above those listed in the operational sections of this specification is not implied. Exposure to absolute maximum rating conditions for extended periods may affect device reliability.

## ORDERING GUIDE

Model	Temperature Range	Package Description	Package Option
AD5332BRU	−40°C to +105°C	TSSOP (Thin Shrink Small Outline Package)	RU-20
AD5333BRU	−40°C to +105°C	TSSOP (Thin Shrink Small Outline Package)	RU-24
AD5342BRU	−40°C to +105°C	TSSOP (Thin Shrink Small Outline Package)	RU-28
AD5343BRU	−40°C to +105°C	TSSOP (Thin Shrink Small Outline Package)	RU-20

## CAUTION

ESD (electrostatic discharge) sensitive device. Electrostatic charges as high as 4000 V readily accumulate on the human body and test equipment and can discharge without detection. Although the AD5332/AD5333/AD5342/AD5343 features proprietary ESD protection circuitry, permanent damage may occur on devices subjected to high-energy electrostatic discharges. Therefore, proper ESD precautions are recommended to avoid performance degradation or loss of functionality.



# AD5332/AD5333/AD5342/AD5343

AD5332 FUNCTIONAL BLOCK DIAGRAM

AD5332 PIN CONFIGURATION

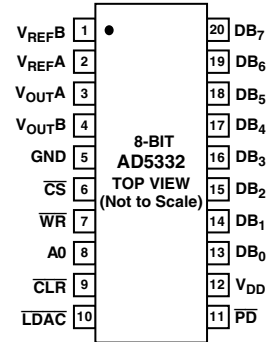
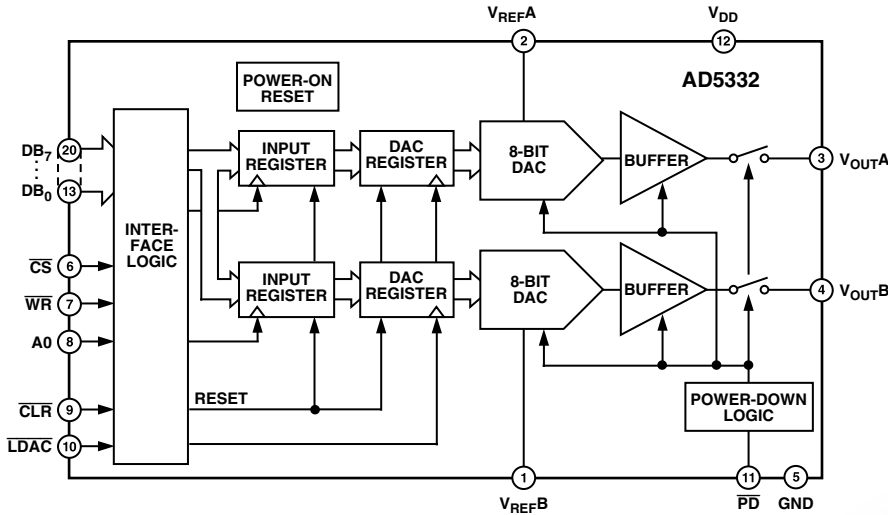

AD5332 PIN FUNCTION DESCRIPTIONS

Pin No.	Mnemonic	Function
1	$V_{REFB}$	Unbuffered reference input for DAC B.
2	$V_{REFA}$	Unbuffered reference input for DAC A.
3	$V_{OUTA}$	Output of DAC A. Buffered output with rail-to-rail operation.
4	$V_{OUTB}$	Output of DAC B. Buffered output with rail-to-rail operation.
5	GND	Ground reference point for all circuitry on the part.
6	$\overline{CS}$	Active low Chip Select Input. This is used in conjunction with $\overline{WR}$ to write data to the parallel interface.
7	$\overline{WR}$	Active low Write Input. This is used in conjunction with $\overline{CS}$ to write data to the parallel interface.
8	A0	Address pin for selecting which DAC A and DAC B.
9	$\overline{CLR}$	Asynchronous active low control input that clears all input registers and DAC registers to zeros.
10	$\overline{LDAC}$	Active low control input that updates the DAC registers with the contents of the input registers. This allows all DAC outputs to be simultaneously updated.
11	$\overline{PD}$	Power-Down Pin. This active low control pin puts all DACs into power-down mode.
12	$V_{DD}$	Power Supply Pin. These parts can operate from 2.5 V to 5.5 V and the supply should be decoupled with a 10 $\mu$ F capacitor in parallel with a 0.1 $\mu$ F capacitor to GND.
13–20	DB <sub>0</sub> –DB <sub>7</sub>	Eight Parallel Data Inputs. DB <sub>7</sub> is the MSB of these eight bits.

# AD5332/AD5333/AD5342/AD5343

AD5333 FUNCTIONAL BLOCK DIAGRAM

AD5333 PIN CONFIGURATION

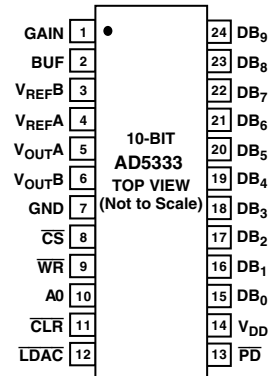
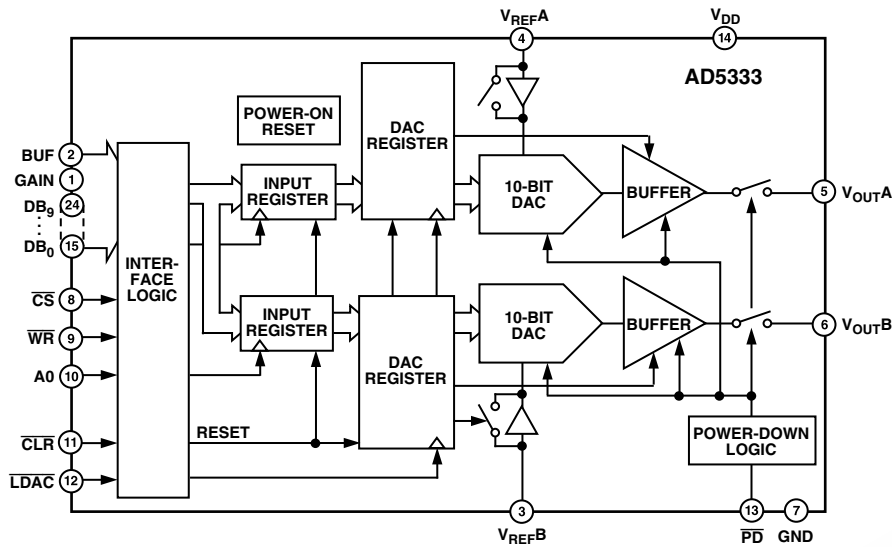

AD5333 PIN FUNCTION DESCRIPTIONS

Pin No.	Mnemonic	Function
1	GAIN	Gain Control Pin. This controls whether the output range from the DAC is $0-V_{REF}$ or $0-2 V_{REF}$ .
2	BUF	Buffer Control Pin. This pin controls whether the reference input to the DAC is buffered or unbuffered.
3	$V_{REFB}$	Reference input for DAC B.
4	$V_{REFA}$	Reference input for DAC A.
5	$V_{OUTA}$	Output of DAC A. Buffered output with rail-to-rail operation.
6	$V_{OUTB}$	Output of DAC B. Buffered output with rail-to-rail operation.
7	GND	Ground reference point for all circuitry on the part.
8	$\overline{CS}$	Active Low Chip Select Input. This is used in conjunction with $\overline{WR}$ to write data to the parallel interface.
9	$\overline{WR}$	Active Low Write Input. This is used in conjunction with $\overline{CS}$ to write data to the parallel interface.
10	A0	Address pin for selecting between DAC A and DAC B.
11	$\overline{CLR}$	Asynchronous active-low control input that clears all input registers and DAC registers to zeros.
12	$\overline{LDAC}$	Active-low control input that updates the DAC registers with the contents of the input registers. This allows all DAC outputs to be simultaneously updated.
13	$\overline{PD}$	Power-Down Pin. This active low control pin puts all DACs into power-down mode.
14	$V_{DD}$	Power Supply Pin. These parts can operate from 2.5 V to 5.5 V and the supply should be decoupled with a 10 $\mu$ F capacitor in parallel with a 0.1 $\mu$ F capacitor to GND.
15–24	DB <sub>0</sub> –DB <sub>9</sub>	10 Parallel Data Inputs. DB <sub>9</sub> is the MSB of these 10 bits.

# AD5332/AD5333/AD5342/AD5343

AD5342 FUNCTIONAL BLOCK DIAGRAM

AD5342 PIN CONFIGURATION

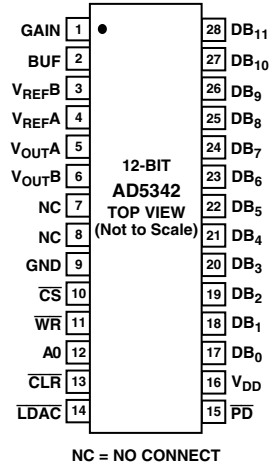
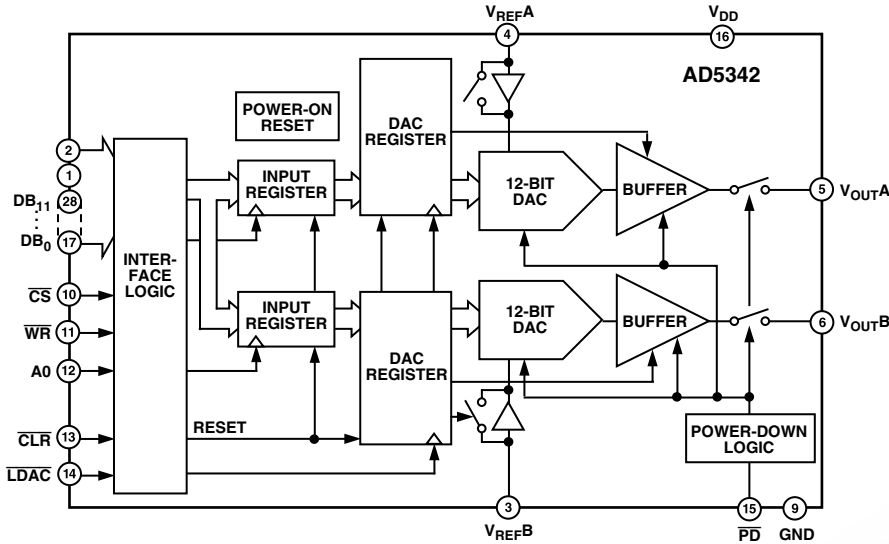

AD5342 PIN FUNCTION DESCRIPTIONS

Pin No.	Mnemonic	Function
1	GAIN	Gain Control Pin. This controls whether the output range from the DAC is $0-V_{REF}$ or $0-2 V_{REF}$ .
2	BUF	Buffer Control Pin. This pin controls whether the reference input to the DAC is buffered or unbuffered.
3	$V_{REFB}$	Reference Input for DAC B.
4	$V_{REFA}$	Reference Input for DAC A.
5	$V_{OUTA}$	Output of DAC A. Buffered output with rail-to-rail operation.
6	$V_{OUTB}$	Output of DAC B. Buffered output with rail-to-rail operation.
7, 8	NC	No Connect.
9	GND	Ground reference point for all circuitry on the part.
10	$\overline{CS}$	Active Low Chip Select Input. This is used in conjunction with $\overline{WR}$ to write data to the parallel interface.
11	$\overline{WR}$	Active low Write Input. This is used in conjunction with $\overline{CS}$ to write data to the parallel interface.
12	A0	Address pin for selecting between DAC A and DAC B.
13	$\overline{CLR}$	Asynchronous active low control input that clears all input registers and DAC registers to zeros.
14	$\overline{LDAC}$	Active low control input that updates the DAC registers with the contents of the input registers. This allows all DAC outputs to be simultaneously updated.
15	$\overline{PD}$	Power-Down Pin. This active low control pin puts all DACs into power-down mode.
16	$V_{DD}$	Power Supply Pin. These parts can operate from 2.5 V to 5.5 V and the supply should be decoupled with a 10 $\mu$ F capacitor in parallel with a 0.1 $\mu$ F capacitor to GND.
17–28	DB <sub>0</sub> –DB <sub>11</sub>	12 Parallel Data Inputs. DB <sub>11</sub> is the MSB of these 12 bits.

# AD5332/AD5333/AD5342/AD5343

## AD5343 FUNCTIONAL BLOCK DIAGRAM

## AD5343 PIN CONFIGURATION

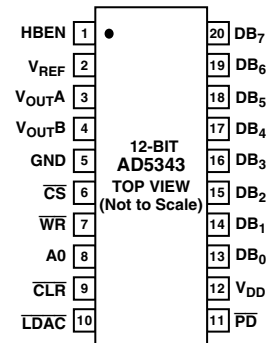
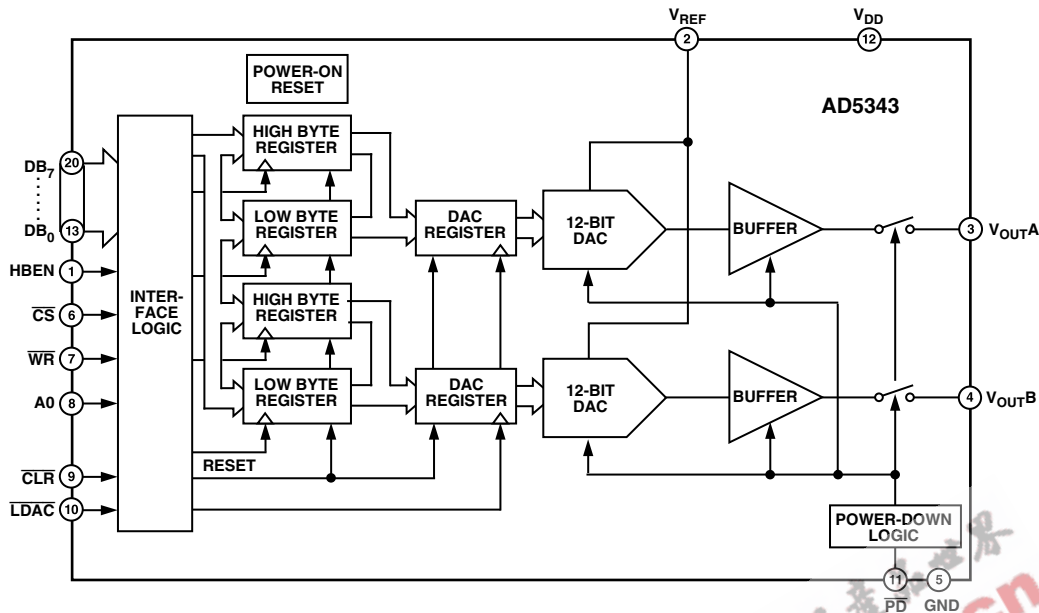

## AD5343 PIN FUNCTION DESCRIPTIONS

Pin No.	Mnemonic	Function
1	HBEN	This pin is used when writing to the device to determine if data is written to the high byte register or the low byte register.
2	$V_{REF}$	Unbuffered reference input for both DACs.
3	$V_{OUTA}$	Output of DAC A. Buffered output with rail-to-rail operation.
4	$V_{OUTB}$	Output of DAC B. Buffered output with rail-to-rail operation.
5	GND	Ground reference point for all circuitry on the part.
6	$\overline{CS}$	Active Low Chip Select Input. This is used in conjunction with $\overline{WR}$ to write data to the parallel interface.
7	$\overline{WR}$	Active Low Write Input. This is used in conjunction with $\overline{CS}$ to write data to the parallel interface.
8	A0	Address pin for selecting between DAC A and DAC B.
9	$\overline{CLR}$	Asynchronous active low control input that clears all input registers and DAC registers to zeros.
10	$\overline{LDAC}$	Active low control input that updates the DAC registers with the contents of the input registers. This allows all DAC outputs to be simultaneously updated.
11	$\overline{PD}$	Power-Down Pin. This active low control pin puts all DACs into power-down mode.
12	$V_{DD}$	Power Supply Pin. These parts can operate from 2.5 V to 5.5 V and the supply should be decoupled with a 10 $\mu$ F capacitor in parallel with a 0.1 $\mu$ F capacitor to GND.
13–20	DB <sub>0</sub> –DB <sub>7</sub>	Eight Parallel Data Inputs. DB <sub>7</sub> is the MSB of these eight bits.



**TERMINOLOGY**

**RELATIVE ACCURACY**

For the DAC, Relative Accuracy or Integral Nonlinearity (INL) is a measure of the maximum deviation, in LSBs, from a straight line passing through the actual endpoints of the DAC transfer function. Typical INL versus Code plot can be seen in Figures 5, 6, and 7.

**DIFFERENTIAL NONLINEARITY**

Differential Nonlinearity (DNL) is the difference between the measured change and the ideal 1 LSB change between any two adjacent codes. A specified differential nonlinearity of  $\pm 1$  LSB maximum ensures monotonicity. This DAC is guaranteed monotonic by design. Typical DNL versus Code plot can be seen in Figures 8, 9, and 10.

**OFFSET ERROR**

This is a measure of the offset error of the DAC and the output amplifier. It is expressed as a percentage of the full-scale range.

If the offset voltage is positive, the output voltage will still be positive at zero input code. This is shown in Figure 3. Because the DACs operate from a single supply, a negative offset cannot appear at the output of the buffer amplifier. Instead, there will be a code close to zero at which the amplifier output saturates (amplifier footroom). Below this code there will be a deadband over which the output voltage will not change. This is illustrated in Figure 4.

**GAIN ERROR**

This is a measure of the span error of the DAC (including any error in the gain of the buffer amplifier). It is the deviation in slope of the actual DAC transfer characteristic from the ideal expressed as a percentage of the full-scale range. This is illustrated in Figure 2.

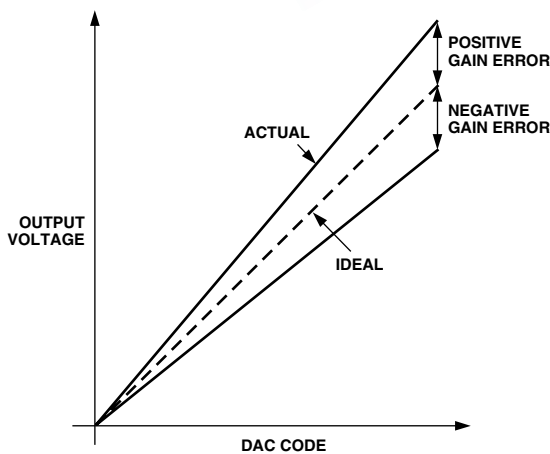

Figure 2. Gain Error

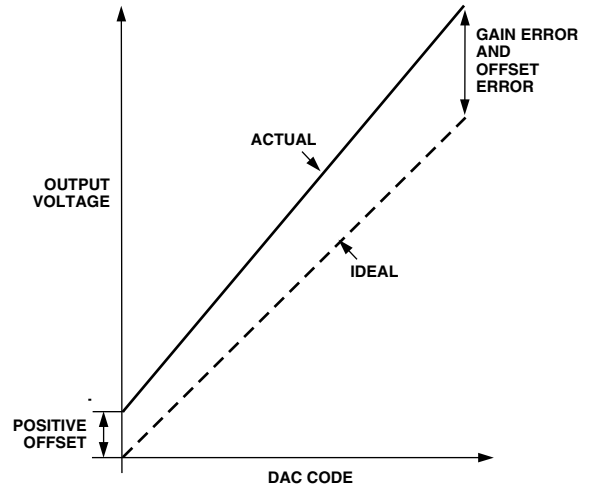

Figure 3. Positive Offset Error and Gain Error

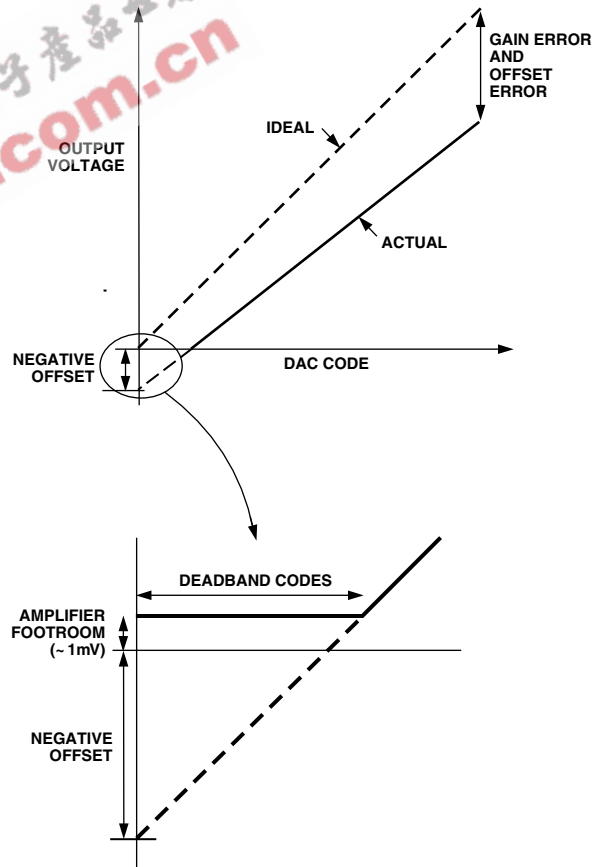

Figure 4. Negative Offset Error and Gain Error

## AD5332/AD5333/AD5342/AD5343

### OFFSET ERROR DRIFT

This is a measure of the change in Offset Error with changes in temperature. It is expressed in (ppm of full-scale range)/°C.

### GAIN ERROR DRIFT

This is a measure of the change in Gain Error with changes in temperature. It is expressed in (ppm of full-scale range)/°C.

### POWER-SUPPLY REJECTION RATIO (PSRR)

This indicates how the output of the DAC is affected by changes in the supply voltage. PSRR is the ratio of the change in  $V_{OUT}$  to a change in  $V_{DD}$  for full-scale output of the DAC. It is measured in dBs.  $V_{REF}$  is held at 2 V and  $V_{DD}$  is varied  $\pm 10\%$ .

### DC CROSSTALK

This is the dc change in the output level of one DAC at mid-scale in response to a full-scale code change (all 0s to all 1s and vice versa) and output change of the other DAC. It is expressed in  $\mu V$ .

### REFERENCE FEEDTHROUGH

This is the ratio of the amplitude of the signal at the DAC output to the reference input when the DAC output is not being updated (i.e.,  $\overline{LDAC}$  is high). It is expressed in dBs.

### CHANNEL-TO-CHANNEL ISOLATION

This is a ratio of the amplitude of the signal at the output of one DAC to a sine wave on the reference input of the other DAC. It is measured by grounding one  $V_{REF}$  pin and applying a 10 kHz, 4 V peak-to-peak sine wave to the other  $V_{REF}$  pin. It is expressed in dBs.

### MAJOR-CODE TRANSITION GLITCH ENERGY

Major-Code Transition Glitch Energy is the energy of the impulse injected into the analog output when the DAC changes state. It is normally specified as the area of the glitch in nV secs and is measured when the digital code is changed by 1 LSB at the major carry transition (011 . . . 11 to 100 . . . 00 or 100 . . . 00 to 011 . . . 11).

### DIGITAL FEEDTHROUGH

Digital Feedthrough is a measure of the impulse injected into the analog output of the DAC from the digital input pins of the device but is measured when the DAC is not being written to ( $\overline{CS}$  held high). It is specified in nV secs and is measured with a full-scale change on the digital input pins, i.e. from all 0s to all 1s and vice versa.

### DIGITAL CROSSTALK

This is the glitch impulse transferred to the output of one DAC at mid-scale in response to a full-scale code change (all 0s to all 1s and vice versa) in the input register of the other DAC. It is expressed in nV-secs.

### ANALOG CROSSTALK

This is the glitch impulse transferred to the output of one DAC due to a change in the output of the other DAC. It is measured by loading one of the input registers with a full-scale code change (all 0s to all 1s and vice versa) while keeping  $\overline{LDAC}$  high. Then pulse  $\overline{LDAC}$  low and monitor the output of the DAC whose digital code was not changed. The area of the glitch is expressed in nV-secs.

### DAC-TO-DAC CROSSTALK

This is the glitch impulse transferred to the output of one DAC due to a digital code change and subsequent output change of the other DAC. This includes both digital and analog crosstalk. It is measured by loading one of the DACs with a full-scale code change (all 0s to all 1s and vice versa) with the  $\overline{LDAC}$  pin set low and monitoring the output of the other DAC. The energy of the glitch is expressed in nV-secs.

### MULTIPLYING BANDWIDTH

The amplifiers within the DAC have a finite bandwidth. The Multiplying Bandwidth is a measure of this. A sine wave on the reference (with full-scale code loaded to the DAC) appears on the output. The Multiplying Bandwidth is the frequency at which the output amplitude falls to 3 dB below the input.

### TOTAL HARMONIC DISTORTION

This is the difference between an ideal sine wave and its attenuated version using the DAC. The sine wave is used as the reference for the DAC and the THD is a measure of the harmonics present on the DAC output. It is measured in dBs.

# Typical Performance Characteristics—AD5332/AD5333/AD5342/AD5343

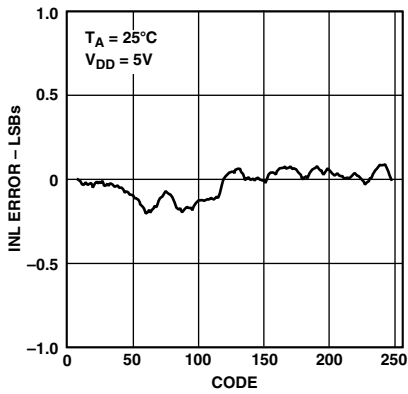

Figure 5. AD5332 Typical INL Plot

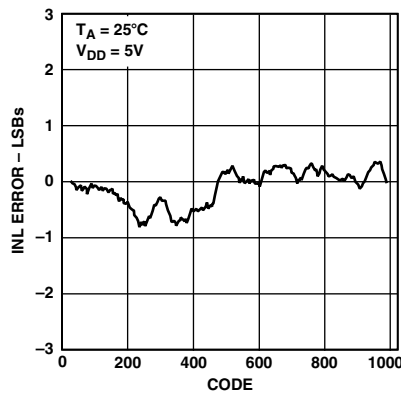

Figure 6. AD5333 Typical INL Plot

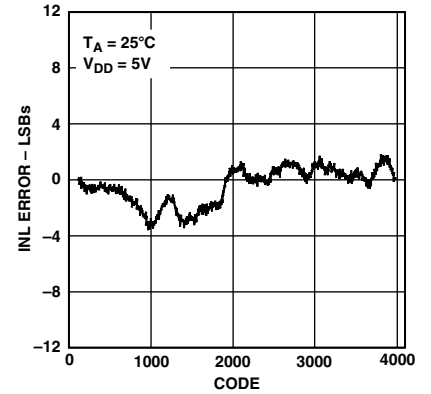

Figure 7. AD5342 Typical INL Plot

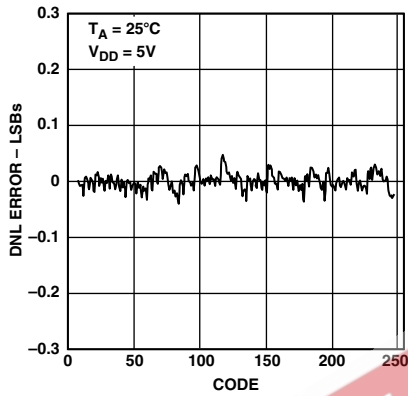

Figure 8. AD5332 Typical DNL Plot

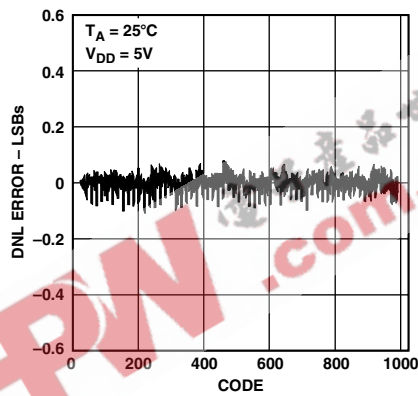

Figure 9. AD5333 Typical DNL Plot

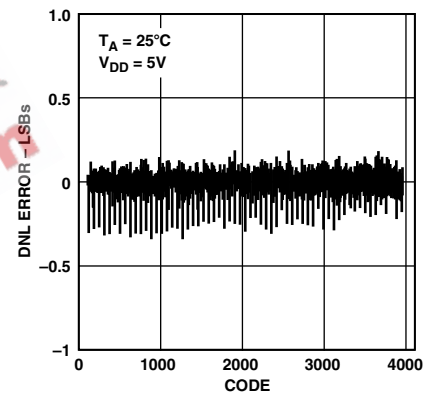

Figure 10. AD5342 Typical DNL Plot

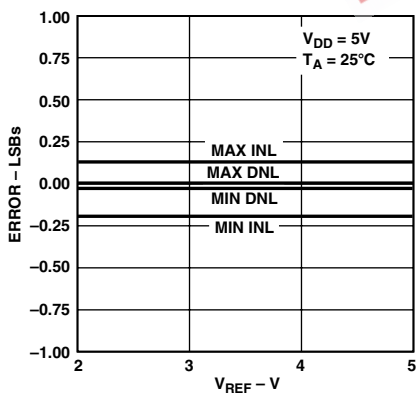

Figure 11. AD5332 INL and DNL Error vs.  $V_{REF}$

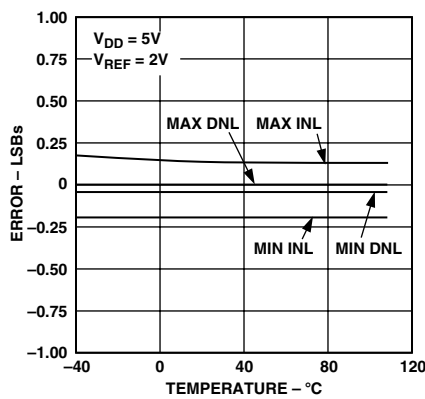

Figure 12. AD5332 INL Error and DNL Error vs. Temperature

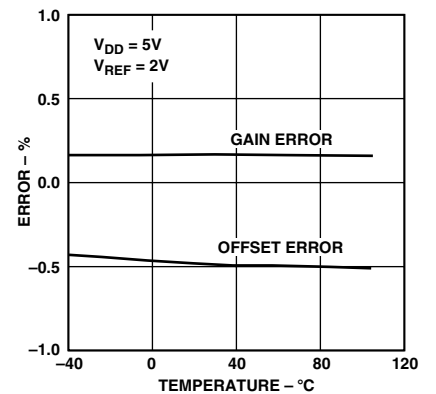

Figure 13. AD5332 Offset Error and Gain Error vs. Temperature

# AD5332/AD5333/AD5342/AD5343

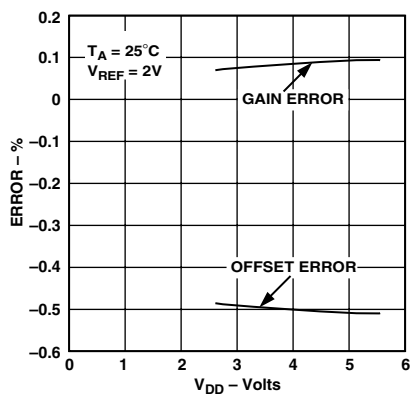

Figure 14. Offset Error and Gain Error vs.  $V_{DD}$

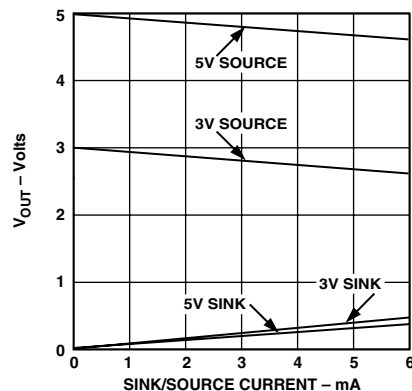

Figure 15.  $V_{OUT}$  Source and Sink Current Capability

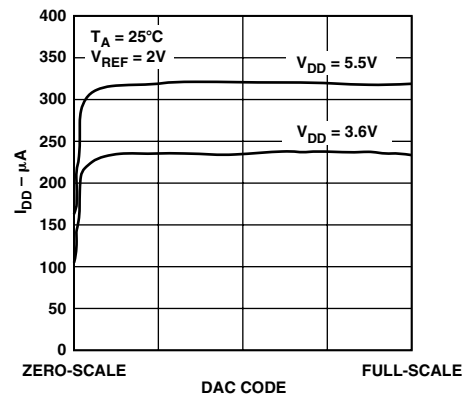

Figure 16. Supply Current vs. DAC Code

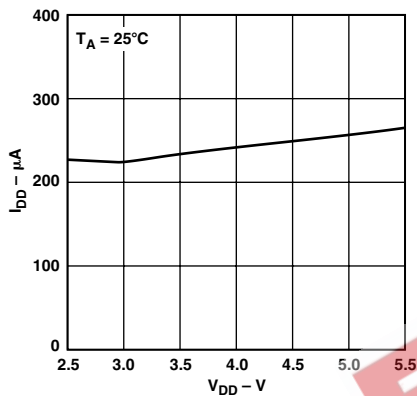

Figure 17. Supply Current vs. Supply Voltage

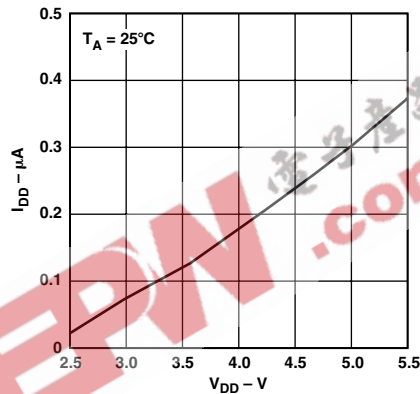

Figure 18. Power-Down Current vs. Supply Voltage

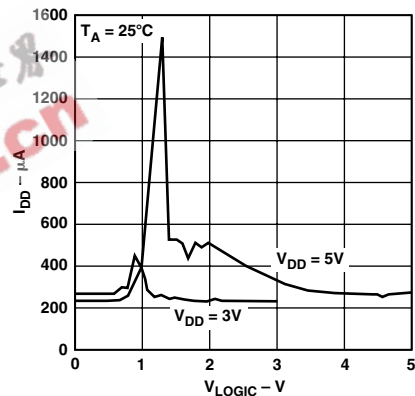

Figure 19. Supply Current vs. Logic Input Voltage

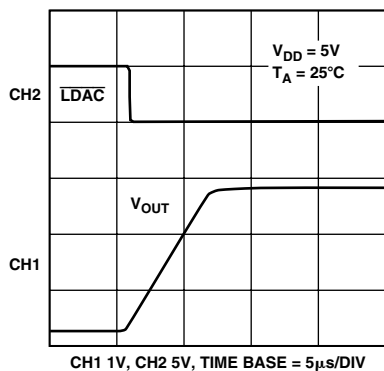

Figure 20. Half-Scale Settling (1/4 to 3/4 Scale Code Change)

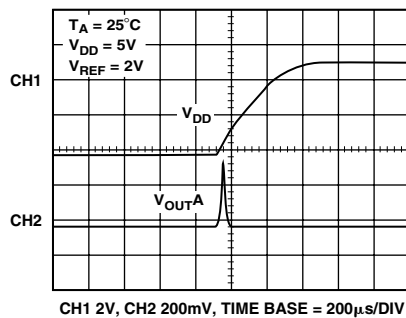

Figure 21. Power-On Reset to 0 V

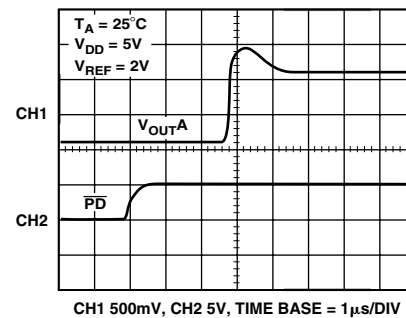

Figure 22. Exiting Power-Down to Midscale

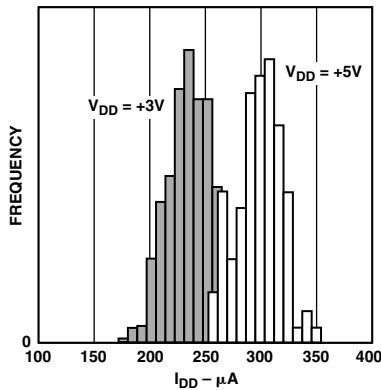

Figure 23.  $I_{DD}$  Histogram with  $V_{DD} = 3$  V and  $V_{DD} = 5$  V

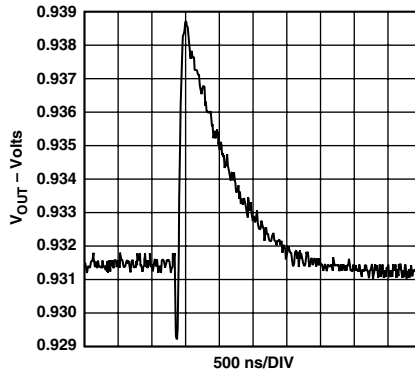

Figure 24. AD5342 Major-Code Transition Glitch Energy

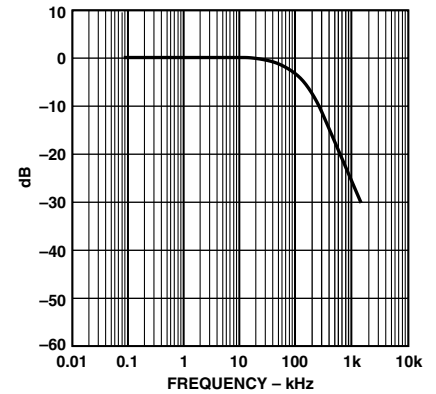

Figure 25. Multiplying Bandwidth (Small-Signal Frequency Response)

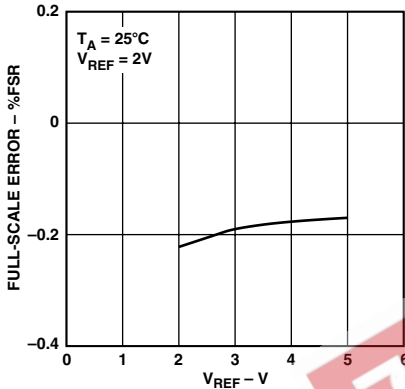

Figure 26. Full-Scale Error vs.  $V_{REF}$

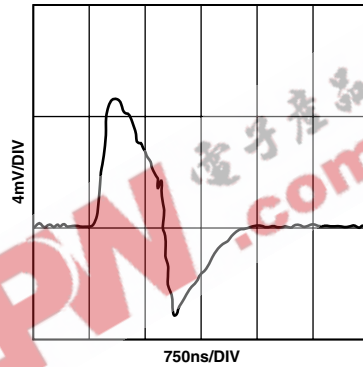

Figure 27. DAC-DAC Crosstalk

## FUNCTIONAL DESCRIPTION

The AD5332/AD5333/AD5342/AD5343 are dual DACs fabricated on a CMOS process with resolutions of 8, 10, 12, and 12 bits, respectively. They are written to using a parallel interface. They operate from single supplies of 2.5 V to 5.5 V and the output buffer amplifiers offer rail-to-rail output swing. The AD5333 and AD5342 have reference inputs that may be buffered to draw virtually no current from the reference source. Their output voltage range may be configured to be 0 to  $V_{REF}$  or 0 to  $2 V_{REF}$ . The reference inputs of the AD5332 and AD5343 are unbuffered and their output range is 0 to  $V_{REF}$ . The devices have a power-down feature that reduces current consumption to only 80 nA @ 3 V.

### Digital-to-Analog Section

The architecture of one DAC channel consists of a reference buffer and a resistor-string DAC followed by an output buffer amplifier. The voltage at the  $V_{REF}$  pin provides the reference voltage for the DAC. Figure 28 shows a block diagram of the DAC architecture. Since the input coding to the DAC is straight binary, the ideal output voltage is given by:

$$V_{OUT} = V_{REF} \times \frac{D}{2^N} \times Gain$$

where:

$D$  = decimal equivalent of the binary code which is loaded to the DAC register:

- 0–255 for AD5332 (8 Bits)
- 0–1023 for AD5333 (10 Bits)
- 0–4095 for AD5342/AD5343 (12 Bits)

$N$  = DAC resolution

$Gain$  = Output Amplifier Gain (1 or 2)

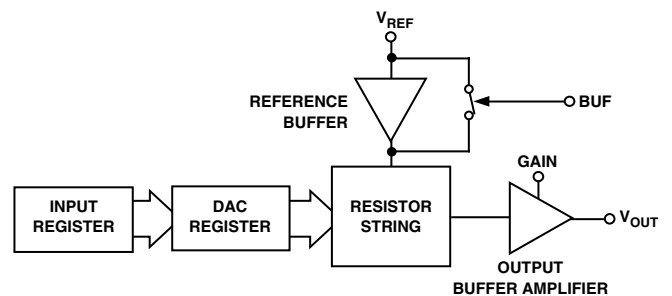

Figure 28. Single DAC Channel Architecture

# AD5332/AD5333/AD5342/AD5343

## Resistor String

The resistor string section is shown in Figure 29. It is simply a string of resistors, each of value  $R$ . The digital code loaded to the DAC register determines at what node on the string the voltage is tapped off to be fed into the output amplifier. The voltage is tapped off by closing one of the switches connecting the string to the amplifier. Because it is a string of resistors, it is guaranteed monotonic.

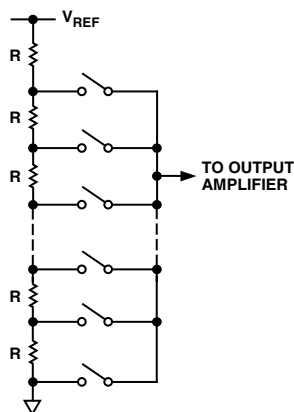

Figure 29. Resistor String

## DAC Reference Input

The DACs operate with an external reference. The AD5332, AD5333, and AD5342 have separate reference inputs for each DAC, while the AD5343 has a single reference input for both DACs. The reference inputs on the AD5333 and AD5342 may be configured as buffered or unbuffered. The reference inputs of the AD5332 and AD5343 are unbuffered. The buffered/unbuffered option is controlled by the BUF pin.

In buffered mode (BUF = 1) the current drawn from an external reference voltage is virtually zero, as the impedance is at least 10 M $\Omega$ . The reference input range is 1 V to  $V_{DD}$ .

In unbuffered mode (BUF = 0) the user can have a reference voltage as low as 0.25 V and as high as  $V_{DD}$  since there is no restriction due to headroom and footroom of the reference amplifier. The impedance is still large at typically 180 k $\Omega$  for 0– $V_{REF}$  mode and 90 k $\Omega$  for 0–2  $V_{REF}$  mode.

If using an external buffered reference (e.g., REF192) there is no need to use the on-chip buffer.

## Output Amplifier

The output buffer amplifier is capable of generating output voltages to within 1 mV of either rail. Its actual range depends on  $V_{REF}$ , GAIN, the load on  $V_{OUT}$  and offset error.

If a gain of 1 is selected (GAIN = 0), the output range is 0.001 V to  $V_{REF}$ .

If a gain of 2 is selected (GAIN = 1), on the AD5333 and AD5342 the output range is 0.001 V to 2  $V_{REF}$ .

The output amplifier is capable of driving a load of 2 k $\Omega$  to GND or  $V_{DD}$ , in parallel with 500 pF to GND or  $V_{DD}$ . The source and sink capabilities of the output amplifier can be seen in Figure 15.

The slew rate is 0.7 V/ $\mu$ s with a half-scale settling time to  $\pm 0.5$  LSB (at 8 bits) of 6  $\mu$ s with the output unloaded. See Figure 20.

## PARALLEL INTERFACE

The AD5332, AD5333, and AD5342 load their data as a single 8-, 10-, or 12-bit word, while the AD5343 loads data as a low byte of 8 bits and a high byte containing 4 bits.

## Double-Buffered Interface

The AD5332/AD5333/AD5342/AD5343 DACs all have double-buffered interfaces consisting of an input register and a DAC register. DAC data, BUF, and GAIN inputs are written to the input register under control of the Chip Select ( $\overline{CS}$ ) and Write ( $\overline{WR}$ ).

Access to the DAC register is controlled by the  $\overline{LDAC}$  function. When  $\overline{LDAC}$  is high, the DAC register is latched and the input register may change state without affecting the contents of the DAC register. However, when  $\overline{LDAC}$  is brought low, the DAC register becomes transparent and the contents of the input register are transferred to it. The gain and buffer control signals are also double-buffered and are only updated when  $\overline{LDAC}$  is taken low.

This is useful if the user requires simultaneous updating of all DACs and peripherals. The user may write to both input registers individually and then, by pulsing the  $\overline{LDAC}$  input low, both outputs will update simultaneously.

Double-buffering is also useful where the DAC data is loaded in two bytes, as in the AD5343, because it allows the whole data word to be assembled in parallel before updating the DAC register. This prevents spurious outputs that could occur if the DAC register were updated with only the high byte or the low byte.

These parts contain an extra feature whereby the DAC register is not updated unless its input register has been updated since the last time that  $\overline{LDAC}$  was brought low. Normally, when  $\overline{LDAC}$  is brought low, the DAC registers are filled with the contents of the input registers. In the case of the AD5332/AD5333/AD5342/AD5343, the part will only update the DAC register if the input register has been changed since the last time the DAC register was updated. This removes unnecessary crosstalk.

## Clear Input ( $\overline{CLR}$ )

$\overline{CLR}$  is an active low, asynchronous clear that resets the input and DAC registers.

## Chip Select Input ( $\overline{CS}$ )

$\overline{CS}$  is an active low input that selects the device.

## Write Input ( $\overline{WR}$ )

$\overline{WR}$  is an active low input that controls writing of data to the device. Data is latched into the input register on the rising edge of  $\overline{WR}$ .

## Load DAC Input ( $\overline{LDAC}$ )

$\overline{LDAC}$  transfers data from the input register to the DAC register (and hence updates the outputs). Use of the  $\overline{LDAC}$  function enables double buffering of the DAC data, GAIN and BUF. There are two  $\overline{LDAC}$  modes:

**Synchronous Mode:** In this mode the DAC register is updated after new data is read in on the rising edge of the  $\overline{WR}$  input.  $\overline{LDAC}$  can be tied permanently low or pulsed as in Figure 1.

**Asynchronous Mode:** In this mode the outputs are not updated at the same time that the input register is written to. When  $\overline{LDAC}$  goes low the DAC register is updated with the contents of the input register.

# AD5332/AD5333/AD5342/AD5343

## High-Byte Enable Input (HBEN)

High-Byte Enable is a control input on the AD5343 only that determines if data is written to the high-byte input register or the low-byte input register.

The low data byte of the AD5343 consists of data bits 0 to 7 at data inputs DB<sub>0</sub> to DB<sub>7</sub>, while the high byte consists of data bits 8 to 11 at data inputs DB<sub>8</sub> to DB<sub>11</sub>. DB<sub>4</sub> to DB<sub>7</sub> are ignored during a high byte write, but they may be used for data to set up the reference input as buffered/unbuffered, and buffer amplifier gain. See Figure 32.

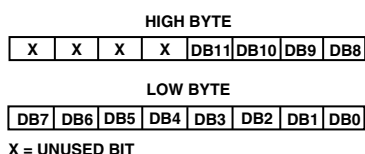

Figure 30. Data Format for AD5343

## POWER-ON RESET

The AD5332/AD5333/AD5342/AD5343 are provided with a power-on reset function, so that they power up in a defined state. The power-on state is:

- Normal operation
- Reference input unbuffered
- 0 – V<sub>REF</sub> output range
- Output voltage set to 0 V

Both input and DAC registers are filled with zeros and remain so until a valid write sequence is made to the device. This is particularly useful in applications where it is important to know the state of the DAC outputs while the device is powering up.

## POWER-DOWN MODE

The AD5332/AD5333/AD5342/AD5343 have low power consumption, dissipating typically 0.69 mW with a 3 V supply and 1.5 mW with a 5 V supply. Power consumption can be further reduced when the DACs are not in use by putting them into power-down mode, which is selected by taking pin  $\overline{\text{PD}}$  low.

When the  $\overline{\text{PD}}$  pin is high, the DACs work normally with a typical power consumption of 300  $\mu\text{A}$  at 5 V (230  $\mu\text{A}$  at 3 V). In power-down mode, however, the supply current falls to 200 nA at 5 V (80 nA at 3 V) when both DACs are powered down. Not only does the supply current drop, but the output stage is also internally switched from the output of the amplifier, making it open-circuit. This has the advantage that the outputs are three-state while the part is in power-down mode, and provides a defined input condition for whatever is connected to the outputs of the DAC amplifiers. The output stage is illustrated in Figure 31.

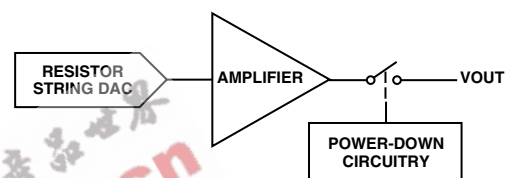

Figure 31. Output Stage During Power-Down

The bias generator, the output amplifier, the resistor string, and all other associated linear circuitry are all shut down when the power-down mode is activated. However, the contents of the registers are unaffected when in power-down. The time to exit power-down is typically 2.5  $\mu\text{s}$  for V<sub>DD</sub> = 5 V and 5  $\mu\text{s}$  when V<sub>DD</sub> = 3 V. This is the time from a rising edge on the  $\overline{\text{PD}}$  pin to when the output voltage deviates from its power-down voltage. See Figure 22.

Table I. AD5332/AD5333/AD5342 Truth Table

CLR	LDAC	CS	WR	A0	Function
1	1	1	X	X	No Data Transfer
1	1	X	1	X	No Data Transfer
0	X	X	X	X	Clear All Registers
1	1	0	0→1	0	Load DAC A Input Register
1	1	0	0→1	1	Load DAC B Input Register
1	0	X	X	X	Update DAC Registers

X = don't care.

Table II. AD5343 Truth Table

CLR	LDAC	CS	WR	A0	HBEN	Function
1	1	1	X	X	X	No Data Transfer
1	1	X	1	X	X	No Data Transfer
0	X	X	X	X	X	Clear All Registers
1	1	0	0→1	0	0	Load DAC A Low Byte Input Register
1	1	0	0→1	0	1	Load DAC A High Byte Input Register
1	1	0	0→1	1	0	Load DAC B Low Byte Input Register
1	1	0	0→1	1	1	Load DAC B High Byte Input Register
1	0	X	X	X	X	Update DAC Registers

X = don't care.

# AD5332/AD5333/AD5342/AD5343

## SUGGESTED DATABUS FORMATS

In most applications GAIN and BUF are hard-wired. However, if more flexibility is required, they can be included in a databus. This enables you to software program GAIN, giving the option of doubling the resolution in the lower half of the DAC range. In a bused system GAIN and BUF may be treated as data inputs since they are written to the device during a write operation and take effect when LDAC is taken low. This means that the reference buffers and the output amplifier gain of multiple DAC devices can be controlled using common GAIN and BUF lines.

The AD5333 and AD5342 databuses must be at least 10, and 12 bits wide respectively, and are best suited to a 16-bit databus system.

Examples of data formats for putting GAIN and BUF on a 16-bit databus are shown in Figure 32. Note that any unused bits above the actual DAC data may be used for BUF and GAIN.

AD5333															
X	X	X	X	BUF	GAIN	DB9	DB8	DB7	DB6	DB5	DB4	DB3	DB2	DB1	DB0

AD5342															
X	X	BUF	GAIN	DB11	DB10	DB9	DB8	DB7	DB6	DB5	DB4	DB3	DB2	DB1	DB0

X = UNUSED BIT

Figure 32. GAIN and BUF Data on a 16-Bit Bus

## APPLICATIONS INFORMATION

### Typical Application Circuits

The AD5332/AD5333/AD5342/AD5343 can be used with a wide range of reference voltages, especially if the reference inputs are configured to be unbuffered, in which case the devices offer full, one-quadrant multiplying capability over a reference range of 0.25 V to V<sub>DD</sub>. More typically, these devices may be used with a fixed, precision reference voltage. Figure 33 shows a typical setup for the devices when using an external reference connected to the unbuffered reference inputs. If the reference inputs are unbuffered, the reference input range is from 0.25 V to V<sub>DD</sub>, but if the on-chip reference buffers are used, the reference range is reduced. Suitable references for 5 V operation are the AD780 and REF192. For 2.5 V operation, a suitable external reference would be the AD589, a 1.23 V bandgap reference.

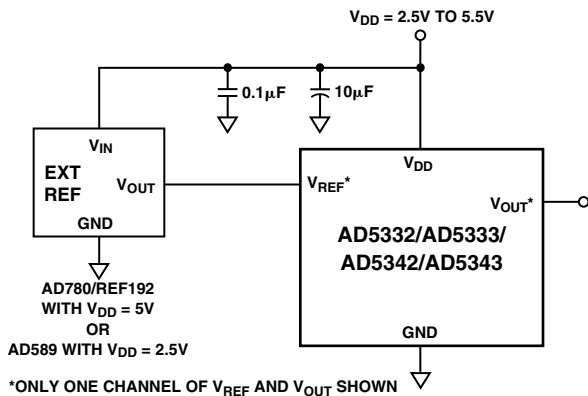

Figure 33. AD5332/AD5333/AD5342/AD5343 Using External Reference

### Driving V<sub>DD</sub> from the Reference Voltage

If an output range of zero to V<sub>DD</sub> is required when the reference inputs are configured as unbuffered, the simplest solution is to connect the reference inputs to V<sub>DD</sub>. As this supply may not be very accurate, and may be noisy, the devices may be powered from the reference voltage, for example using a 5 V reference such as the ADM663 or ADM666, as shown in Figure 34.

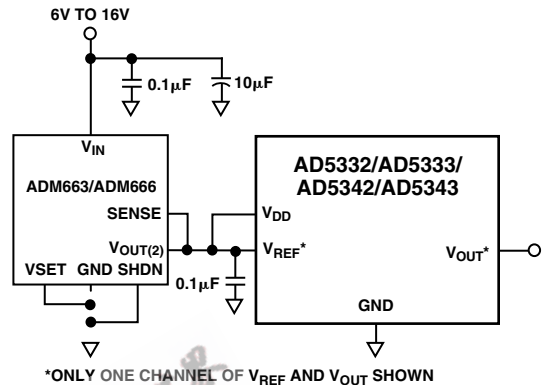

Figure 34. Using an ADM663/ADM666 as Power and Reference to AD5332/AD5333/AD5342/AD5343

### Bipolar Operation Using the AD5332/AD5333/AD5342/AD5343

The AD5332/AD5333/AD5342/AD5343 have been designed for single supply operation, but bipolar operation is achievable using the circuit shown in Figure 35. The circuit shown has been configured to achieve an output voltage range of -5 V < V<sub>O</sub> < +5 V. Rail-to-rail operation at the amplifier output is achievable using an AD820 or OP295 as the output amplifier.

The output voltage for any input code can be calculated as follows:

$$V_O = [(1 + R_4/R_3) \times (R_2/(R_1 + R_2) \times (2 \times V_{REF} \times D/2^N))] - R_4 \times V_{REF}/R_3$$

where:

D is the decimal equivalent of the code loaded to the DAC, N is DAC resolution and V<sub>REF</sub> is the reference voltage input.

With:

$$\begin{aligned} V_{REF} &= 2.5 \text{ V} \\ R_1 &= R_3 = 10 \text{ k}\Omega \\ R_2 &= R_4 = 20 \text{ k}\Omega \text{ and } V_{DD} = 5 \text{ V.} \\ V_{OUT} &= (10 \times D/2^N) - 5 \end{aligned}$$

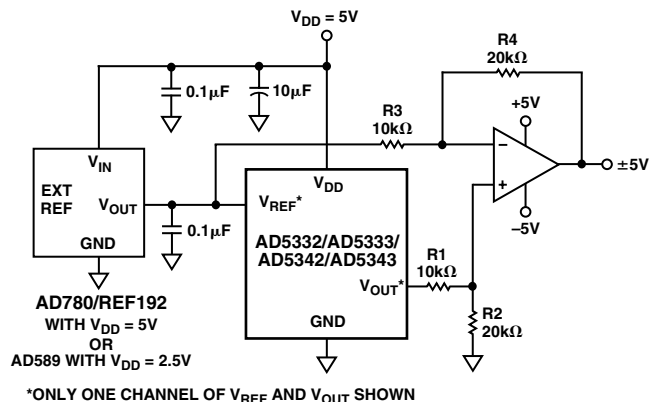

Figure 35. Bipolar Operation using the AD5332/AD5333/AD5342/AD5343



# AD5332/AD5333/AD5342/AD5343

## Decoding Multiple AD5332/AD5333/AD5342/AD5343

The  $\overline{CS}$  pin on these devices can be used in applications to decode a number of DACs. In this application, all DACs in the system receive the same data and  $\overline{WR}$  pulses, but only the  $\overline{CS}$  to one of the DACs will be active at any one time, so data will only be written to the DAC whose  $\overline{CS}$  is low. If multiple AD5343s are being used, a common HBEN line will also be required to determine if the data is written to the high-byte or low-byte register of the selected DAC.

The 74HC139 is used as a 2- to 4-line decoder to address any of the DACs in the system. To prevent timing errors from occurring, the enable input should be brought to its inactive state while the coded address inputs are changing state. Figure 36 shows a diagram of a typical setup for decoding multiple devices in a system. Once data has been written sequentially to all DACs in a system, all the DACs can be updated simultaneously using a common  $\overline{LDAC}$  line. A common  $\overline{CLR}$  line can also be used to reset all DAC outputs to zero.

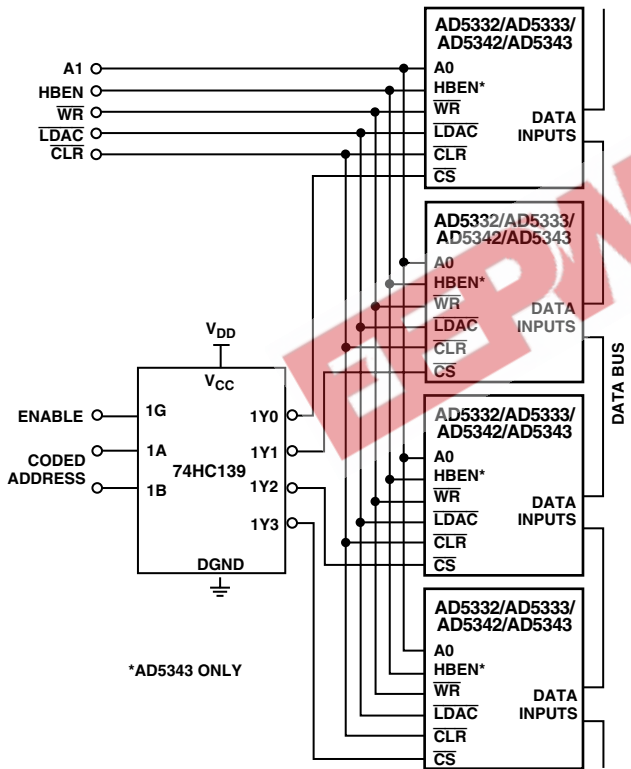

Figure 36. Decoding Multiple DAC Devices

## AD5332/AD5333/AD5342/AD5343 as a Digitally Programmable Window Detector

A digitally programmable upper/lower limit detector using the two DACs in the AD5332/AD5333/AD5342 is shown in Figure 37. The upper and lower limits for the test are loaded to DACs A and B which, in turn, set the limits on the CMP04. If a signal at the  $V_{IN}$  input is not within the programmed window, an LED will indicate the fail condition.

Note that the AD5343 has only a single reference input. If using the AD5332, AD5333, or AD5342, both reference inputs must be connected.

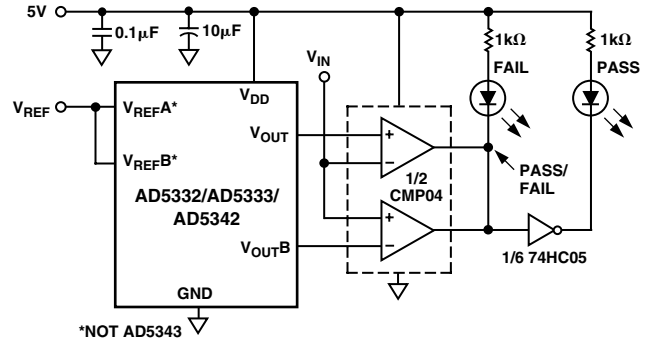

Figure 37. Programmable Window Detector

## Programmable Current Source

Figure 38 shows the AD5332/AD5333/AD5342/AD5343 used as the control element of a programmable current source. In this example, the full-scale current is set to 1 mA. The output voltage from the DAC is applied across the current setting resistor of 4.7 k $\Omega$  in series with the 470  $\Omega$  adjustment potentiometer, which gives an adjustment of about  $\pm 5\%$ . Suitable transistors to place in the feedback loop of the amplifier include the BC107 and the 2N3904, which enable the current source to operate from a minimum  $V_{SOURCE}$  of 6 V. The operating range is determined by the operating characteristics of the transistor. Suitable amplifiers include the AD820 and the OP295, both having rail-to-rail operation on their outputs. The current for any digital input code and resistor value can be calculated as follows:

$$I = G \times V_{REF} \times \frac{D}{(2^N \times R)} \text{ mA}$$

Where:

$G$  is the gain of the buffer amplifier (1 or 2)

$D$  is the digital equivalent of the digital input code

$N$  is the DAC resolution (8, 10, or 12 bits)

$R$  is the sum of the resistor plus adjustment potentiometer in k $\Omega$

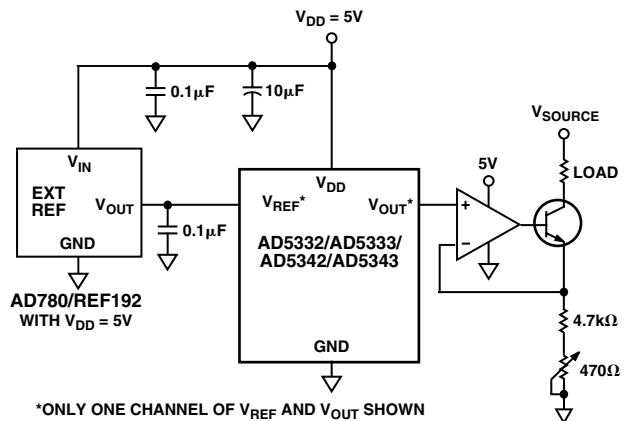

Figure 38. Programmable Current Source

# AD5332/AD5333/AD5342/AD5343

## Coarse and Fine Adjustment Using the AD5332/AD5333/AD5342/AD5343

The DACs in the AD5332/AD5333/AD5342/AD5343 can be paired together to form a coarse and fine adjustment function, as shown in Figure 39. DAC A is used to provide the coarse adjustment while DAC B provides the fine adjustment. Varying the ratio of R1 and R2 will change the relative effect of the coarse and fine adjustments. With the resistor values shown the output amplifier has unity gain for the DAC A output, so the output range is 0 V to 2.5 V – 1 LSB. For DAC B the amplifier has a gain of  $7.6 \times 10^{-3}$ , giving DAC B a range equal to 2 LSBs of DAC A.

The circuit is shown with a 2.5 V reference, but reference voltages up to  $V_{DD}$  may be used. The op amps indicated will allow a rail-to-rail output swing.

Note that the AD5343 has only a single reference input. If using the AD5332, AD5333, or AD5342, both reference inputs must be connected.

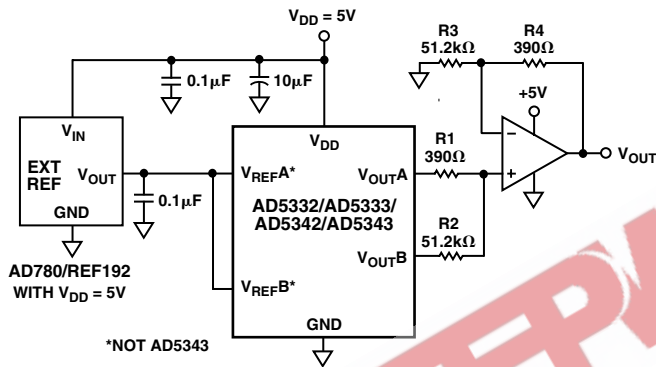

Figure 39. Coarse and Fine Adjustment

## Power Supply Bypassing and Grounding

In any circuit where accuracy is important, careful consideration of the power supply and ground return layout helps to ensure the rated performance. The printed circuit board on which the AD5332/AD5333/AD5342/AD5343 is mounted should be designed so that the analog and digital sections are separated, and confined to certain areas of the board. If the device is in a system where multiple devices require an AGND-to-DGND connection, the connection should be made at one point only. The star ground point should be established as closely as possible to the device. The AD5332/AD5333/AD5342/AD5343 should have ample supply bypassing of 10 µF in parallel with 0.1 µF on the supply located as close to the package as possible, ideally right up against the device. The 10 µF capacitors are the tantalum bead type. The 0.1 µF capacitor should have low Effective Series Resistance (ESR) and Effective Series Inductance (ESI), like the common ceramic types that provide a low impedance path to ground at high frequencies to handle transient currents due to internal logic switching.

The power supply lines of the device should use as large a trace as possible to provide low impedance paths and reduce the effects of glitches on the power supply line. Fast switching signals such as clocks should be shielded with digital ground to avoid radiating noise to other parts of the board, and should never be run near the reference inputs. Avoid crossover of digital and analog signals. Traces on opposite sides of the board should run at right angles to each other. This reduces the effects of feed-through through the board. A microstrip technique is by far the best, but not always possible with a double-sided board. In this technique, the component side of the board is dedicated to ground plane while signal traces are placed on the solder side.

# AD5332/AD5333/AD5342/AD5343

**Table III. Overview of AD53xx Parallel Devices**

Part No.	Resolution	DNL	V <sub>REF</sub> Pins	Settling Time	Additional Pin Functions				Package	Pins
					BUF	GAIN	HBEN	CLR		
<b>SINGLES</b>										
AD5330	8	±0.25	1	6 μs	✓	✓		✓	TSSOP	20
AD5331	10	±0.5	1	7 μs		✓		✓	TSSOP	20
AD5340	12	±1.0	1	8 μs	✓	✓		✓	TSSOP	24
AD5341	12	±1.0	1	8 μs	✓	✓	✓	✓	TSSOP	20
<b>DUALS</b>										
AD5332	8	±0.25	2	6 μs				✓	TSSOP	20
AD5333	10	±0.5	2	7 μs	✓	✓		✓	TSSOP	24
AD5342	12	±1.0	2	8 μs	✓	✓		✓	TSSOP	28
AD5343	12	±1.0	1	8 μs			✓	✓	TSSOP	20
<b>QUADS</b>										
AD5334	8	±0.25	2	6 μs		✓		✓	TSSOP	24
AD5335	10	±0.5	2	7 μs			✓	✓	TSSOP	24
AD5336	10	±0.5	4	7 μs		✓		✓	TSSOP	28
AD5344	12	±1.0	4	8 μs				✓	TSSOP	28

**Table IV. Overview of AD53xx Serial Devices**

Part No.	Resolution	No. of DACS	DNL	Interface	Settling Time	Package	Pins
<b>SINGLES</b>							
AD5300	8	1	±0.25	SPI	4 μs	SOT-23, MicroSOIC	6, 8
AD5310	10	1	±0.5	SPI	6 μs	SOT-23, MicroSOIC	6, 8
AD5320	12	1	±1.0	SPI	8 μs	SOT-23, MicroSOIC	6, 8
AD5301	8	1	±0.25	2-Wire	6 μs	SOT-23, MicroSOIC	6, 8
AD5311	10	1	±0.5	2-Wire	7 μs	SOT-23, MicroSOIC	6, 8
AD5321	12	1	±1.0	2-Wire	8 μs	SOT-23, MicroSOIC	6, 8
<b>DUALS</b>							
AD5302	8	2	±0.25	SPI	6 μs	MicroSOIC	8
AD5312	10	2	±0.5	SPI	7 μs	MicroSOIC	8
AD5322	12	2	±1.0	SPI	8 μs	MicroSOIC	8
AD5303	8	2	±0.25	SPI	6 μs	TSSOP	16
AD5313	10	2	±0.5	SPI	7 μs	TSSOP	16
AD5323	12	2	±1.0	SPI	8 μs	TSSOP	16
<b>QUADS</b>							
AD5304	8	4	±0.25	SPI	6 μs	MicroSOIC	10
AD5314	10	4	±0.5	SPI	7 μs	MicroSOIC	10
AD5324	12	4	±1.0	SPI	8 μs	MicroSOIC	10
AD5305	8	4	±0.25	2-Wire	6 μs	MicroSOIC	10
AD5315	10	4	±0.5	2-Wire	7 μs	MicroSOIC	10
AD5325	12	4	±1.0	2-Wire	8 μs	MicroSOIC	10
AD5306	8	4	±0.25	2-Wire	6 μs	TSSOP	16
AD5316	10	4	±0.5	2-Wire	7 μs	TSSOP	16
AD5326	12	4	±1.0	2-Wire	8 μs	TSSOP	16
AD5307	8	4	±0.25	SPI	6 μs	TSSOP	16
AD5317	10	4	±0.5	SPI	7 μs	TSSOP	16
AD5327	12	4	±1.0	SPI	8 μs	TSSOP	16

Visit our web-page at [http://www.analog.com/support/standard\\_linear/selection\\_guides/AD53xx.html](http://www.analog.com/support/standard_linear/selection_guides/AD53xx.html)

# AD5332/AD5333/AD5342/AD5343

## OUTLINE DIMENSIONS

Dimensions shown in inches and (mm).

### 20-Lead Thin Shrink Small Outline Package TSSOP (RU-20)

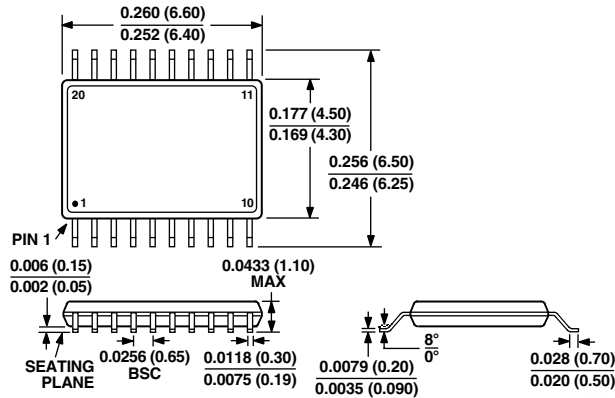

### 24-Lead Thin Shrink Small Outline Package TSSOP (RU-24)

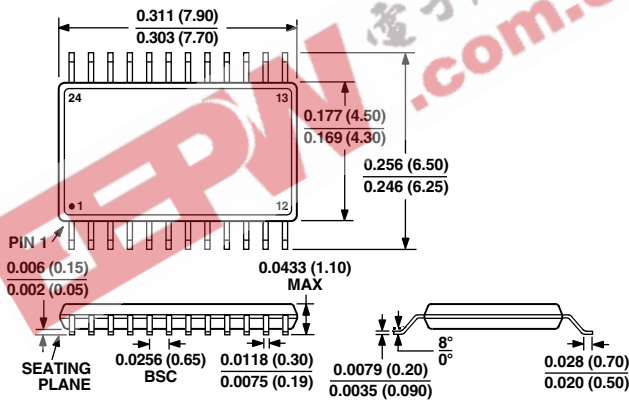

### 28-Lead Thin Shrink Small Outline Package TSSOP (RU-28)

