

DATA SHEET

For a complete data sheet, please also download:

- The IC06 74HC/HCT/HCU/HCMOS Logic Family Specifications
- The IC06 74HC/HCT/HCU/HCMOS Logic Package Information
- The IC06 74HC/HCT/HCU/HCMOS Logic Package Outlines

EEPW 电子产品世界
.com.cn

74HC/HCT139 Dual 2-to-4 line decoder/demultiplexer

Product specification
File under Integrated Circuits, IC06

September 1993

Dual 2-to-4 line decoder/demultiplexer

74HC/HCT139

FEATURES

- Demultiplexing capability
- Two independent 2-to-4 decoders
- Multifunction capability
- Active LOW mutually exclusive outputs
- Output capability: standard
- I_{CC} category: MSI

GENERAL DESCRIPTION

The 74HC/HCT139 are high-speed Si-gate CMOS devices and are pin compatible with low power Schottky TTL (LSTTL). It is specified in compliance with JEDEC standard no. 7A.

The 74HC/HCT139 are high-speed, dual 2-to-4 line decoder/multiplexers. This device has two independent decoders, each accepting two binary weighted inputs (nA_0 and nA_1) and providing four mutually exclusive active LOW outputs ($n\bar{Y}_0$ to $n\bar{Y}_3$). Each decoder has an active LOW enable input ($n\bar{E}$).

When $n\bar{E}$ is HIGH, every output is forced HIGH. The enable can be used as the data input for a 1-to-4 demultiplexer application.

The "139" is identical to the HEF4556 of the HE4000B family.

QUICK REFERENCE DATA

GND = 0 V; T_{amb} = 25 °C; t_r = t_f = 6 ns

SYMBOL	PARAMETER	CONDITIONS	TYPICAL		UNIT
			HC	HCT	
t _{PHL} / t _{PLH}	propagation delay	C _L = 15 pF; V _{CC} = 5 V			
	nA _n to n \bar{Y}_n n \bar{E}_3 to n \bar{Y}_n		11 10	13 13	ns ns
C _I	input capacitance		3.5	3.5	pF
C _{PD}	power dissipation capacitance per multiplexer	notes 1 and 2	42	44	pF

Notes

1. C_{PD} is used to determine the dynamic power dissipation (P_D in μW):

$$P_D = C_{PD} \times V_{CC}^2 \times f_i + \sum (C_L \times V_{CC}^2 \times f_o) \text{ where:}$$

f_i = input frequency in MHz

f_o = output frequency in MHz

∑ (C_L × V_{CC}² × f_o) = sum of outputs

C_L = output load capacitance in pF

V_{CC} = supply voltage in V

2. For HC the condition is V_I = GND to V_{CC}
For HCT the condition is V_I = GND to V_{CC} – 1.5 V

APPLICATIONS

- Memory decoding or data-routing
- Code conversion

ORDERING INFORMATION

See "74HC/HCT/HCU/HCMOS Logic Package Information".

Dual 2-to-4 line decoder/demultiplexer

74HC/HCT139

PIN DESCRIPTION

PIN NO.	SYMBOL	NAME AND FUNCTION
1, 15	$1\bar{E}, 2\bar{E}$	enable inputs (active LOW)
2, 3	$1A_0, 1A_1$	address inputs
4, 5, 6, 7	$1\bar{Y}_0$ to $1\bar{Y}_3$	outputs (active LOW)
8	GND	ground (0 V)
12, 11, 10, 9	$2\bar{Y}_0$ to $2\bar{Y}_3$	outputs (active LOW)
14, 13	$2A_0, 2A_1$	address inputs
16	V_{CC}	positive supply voltage

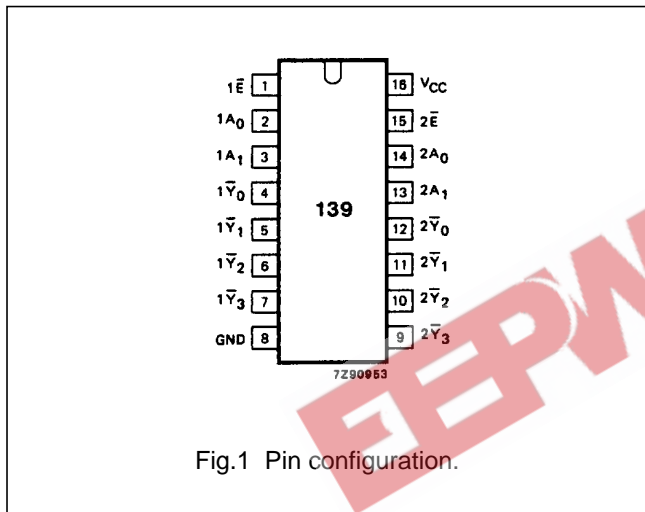

Fig.1 Pin configuration.

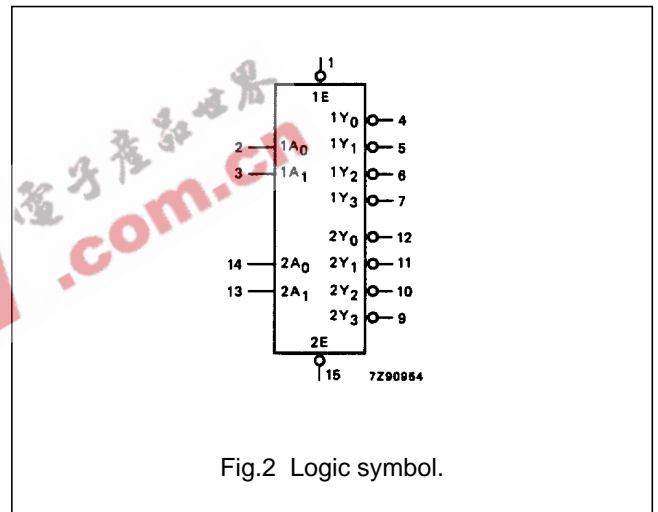

Fig.2 Logic symbol.

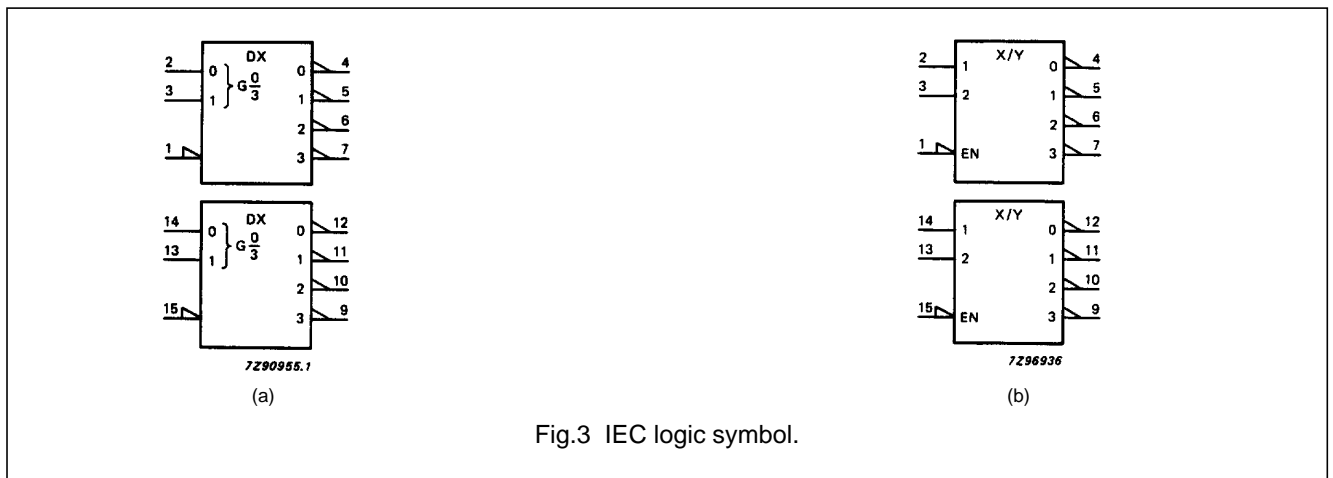

Fig.3 IEC logic symbol.

Dual 2-to-4 line decoder/demultiplexer

74HC/HCT139

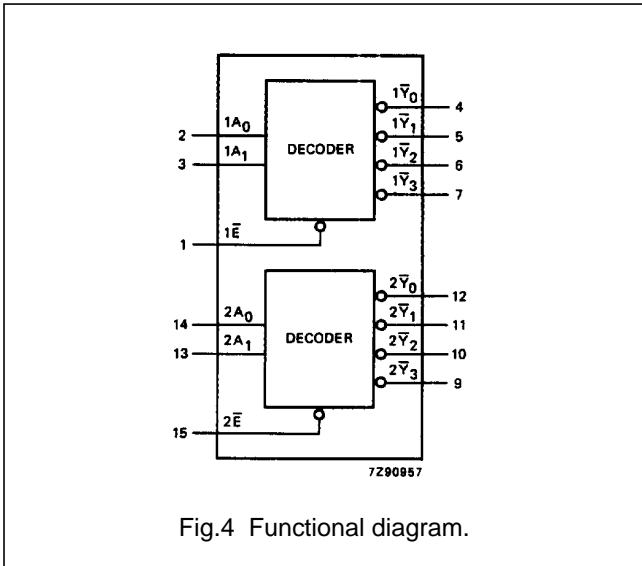

Fig.4 Functional diagram.

FUNCTION TABLE

INPUTS			OUTPUTS			
$n\bar{E}$	nA_0	nA_1	$n\bar{Y}_0$	$n\bar{Y}_1$	$n\bar{Y}_2$	$n\bar{Y}_3$
H	X	X	H	H	H	H
L	L	L	L	H	H	H
L	H	L	H	L	H	H
L	L	H	H	H	L	H
L	H	H	H	H	H	L

Notes

- H = HIGH voltage level
L = LOW voltage level
X = don't care

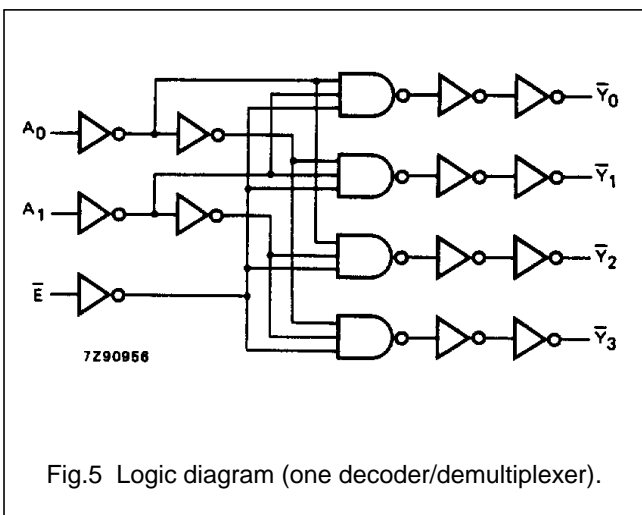

Fig.5 Logic diagram (one decoder/demultiplexer).

Dual 2-to-4 line decoder/demultiplexer

74HC/HCT139

DC CHARACTERISTICS FOR 74HC

For the DC characteristics see *"74HC/HCT/HCU/HCMOS Logic Family Specifications"*.

Output capability: standard

I_{CC} category: MSI

AC CHARACTERISTICS FOR 74HC

GND = 0 V; t_r = t_f = 6 ns; C_L = 50 pF

SYMBOL	PARAMETER	T _{amb} (°C)						UNIT	TEST CONDITIONS		
		74HC							V _{CC} (V)	WAVEFORMS	
		+25			-40 to +85		-40 to +125				
		min.	typ.	max.	min.	max.	min.				max.
t _{PHL} / t _{PLH}	propagation delay nA _n to \bar{Y}_n		39 14 11	145 29 25		180 36 31		220 44 38	ns	2.0 4.5 6.0	Fig.6
t _{PHL} / t _{PLH}	propagation delay n \bar{E} to n \bar{Y}_n		33 12 10	135 27 23		170 34 29		205 41 35	ns	2.0 4.5 6.0	Fig.7
t _{THL} / t _{TLH}	output transition time		19 7 6	75 15 13		95 19 16		110 22 19	ns	2.0 4.5 6.0	Figs 6 and 7

Dual 2-to-4 line decoder/demultiplexer

74HC/HCT139

DC CHARACTERISTICS FOR HCT

For the DC characteristics see "*74HC/HCT/HCU/HCMOS Logic Family Specifications*".

Output capability: standard

I_{CC} category: MSI

Note to HCT types

The value of additional quiescent supply current (ΔI_{CC}) for a unit load of 1 is given in the family specifications. To determine ΔI_{CC} per input, multiply this value by the unit load coefficient shown in the table below.

INPUT	UNIT LOAD COEFFICIENT
1A _n	0.70
2A _n	0.70
n \bar{E}	1.35

AC CHARACTERISTICS FOR 74HCT

GND = 0 V; t_r = t_f = 6 ns; C_L = 50 pF

SYMBOL	PARAMETER	T _{amb} (°C)								UNIT	TEST CONDITIONS	
		74HCT									V _{CC} (V)	WAVEFORMS
		+25			-40 to +85		-40 to +125					
		min.	typ.	max.	min.	max.	min.	max.				
t _{PHL} / t _{PLH}	propagation delay nA _n to \bar{Y}_n		16	34		43		51	ns	4.5	Fig.6	
t _{PHL} / t _{PLH}	propagation delay n \bar{E} to n \bar{Y}_n		16	34		43		51	ns	4.5	Fig.7	
t _{THL} / t _{TLH}	output transition time		7	15		19		22	ns	4.5	Figs 6 and 7	

Dual 2-to-4 line decoder/demultiplexer

74HC/HCT139

AC WAVEFORMS

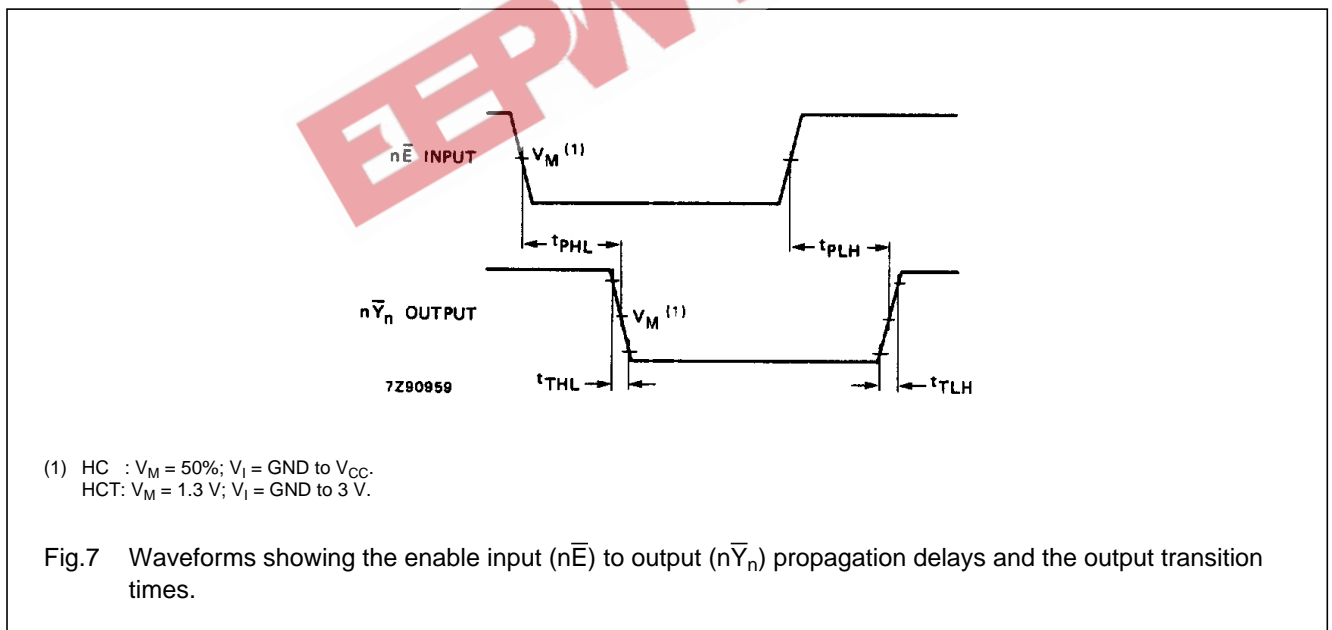
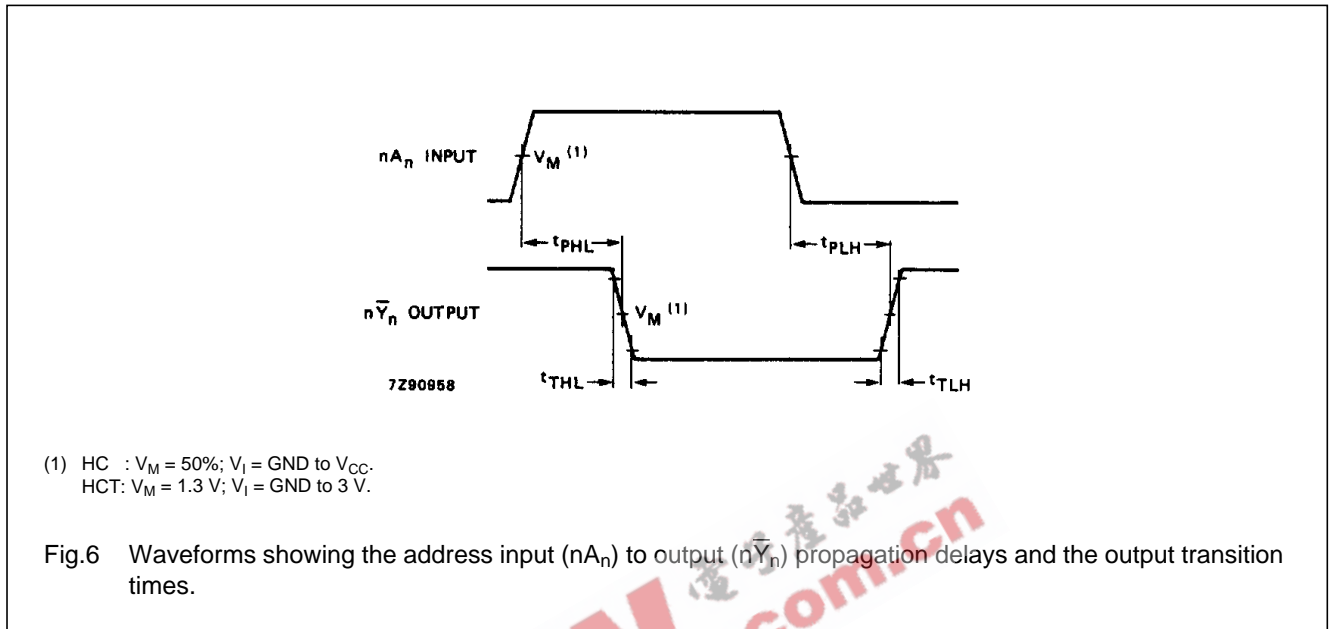

PACKAGE OUTLINES

See "74HC/HCT/HCU/HCMOS Logic Package Outlines".