

DATA SHEET

EEPW 电子产品世界
.com.cn

74LVC00A

Quad 2-input NAND gate

Product specification
Supersedes data of 1997 Aug 11
IC24 Data Handbook

1998 Apr 28

Quad 2-input NAND gate

74LVC00A

FEATURES

- Wide supply range of 1.2V to 3.6V
- Complies with JEDEC standard no. 8-1A
- Inputs accept voltages up to 5.5V
- CMOS low power consumption
- Direct interface with TTL levels
- 5-volt tolerant inputs, for interfacing with 5-volt logic

DESCRIPTION

The 74LVC00A is a high-performance, low power, low-voltage, Si-gate CMOS device and superior to most advanced CMOS compatible TTL families.

Inputs can be driven from either 3.3 V or 5 V devices. This feature allows the use of these devices as translators in a mixed 3.3 V/5 V environment.

Schmitt-trigger action at all inputs makes the circuit tolerant for slower input rise and fall times.

The 74LVC00A provides the 2-input NAND function.

QUICK REFERENCE DATA

GND = 0 V; T_{amb} = 25°C; t_r = t_f ≤ 2.5 ns

SYMBOL	PARAMETER	CONDITIONS	TYPICAL	UNIT
t _{PHL} t _{PLH}	Propagation delay nA, nB to nY	C _L = 50 pF; V _{CC} = 3.3 V	3.0	ns
C _I	Input capacitance		5.0	pF
C _{PD}	Power dissipation capacitance per gate	V _I = GND to V _{CC} ¹	28	pF

NOTES:

- C_{PD} is used to determine the dynamic power dissipation (P_D in μW)
 $P_D = C_{PD} \times V_{CC}^2 \times f_i + \sum (C_L \times V_{CC}^2 \times f_o)$ where:
 f_i = input frequency in MHz; C_L = output load capacity in pF;
 f_o = output frequency in MHz; V_{CC} = supply voltage in V;
 $\sum (C_L \times V_{CC}^2 \times f_o)$ = sum of the outputs.

ORDERING INFORMATION

PACKAGES	TEMPERATURE RANGE	OUTSIDE NORTH AMERICA	NORTH AMERICA	DWG NUMBER
14-Pin Plastic SO	-40°C to +85°C	74LVC00A D	74LVC00A D	SOT108-1
14-Pin Plastic SSOP Type II	-40°C to +85°C	74LVC00A DB	74LVC00A DB	SOT337-1
14-Pin Plastic TSSOP Type I	-40°C to +85°C	74LVC00A PW	74LVC00APW DH	SOT402-1

PIN CONFIGURATION

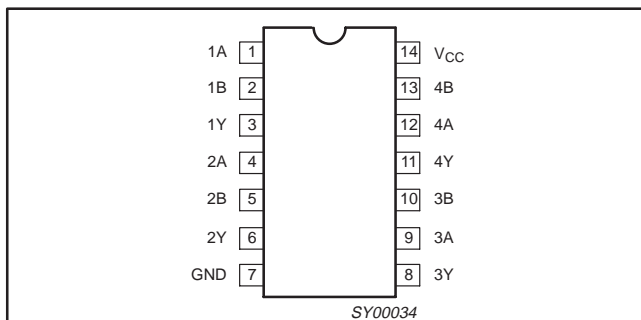

LOGIC SYMBOL

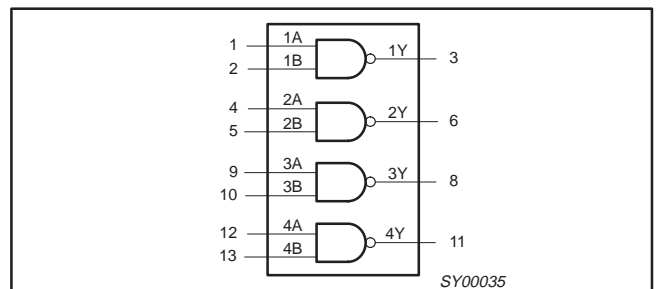

LOGIC SYMBOL (IEEE/IEC)

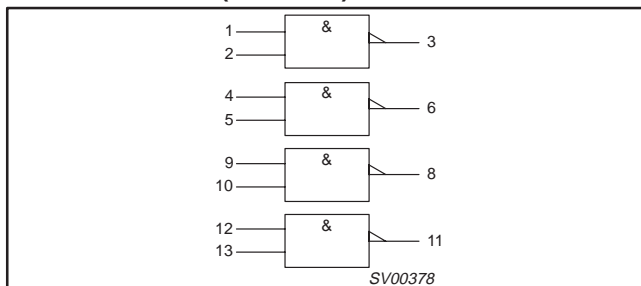

PIN DESCRIPTION

PIN NUMBER	SYMBOL	NAME AND FUNCTION
1, 4, 9, 12	1A – 4A	Data inputs
2, 5, 10, 13	1B – 4B	
3, 6, 8, 11	1Y – 4Y	Data outputs
7	GND	Ground (0 V)
14	V _{CC}	Positive supply voltage

Quad 2-input NAND gate

74LVC00A

LOGIC DIAGRAM (ONE GATE)

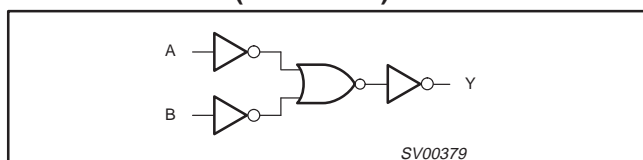

FUNCTION TABLE

INPUTS		OUTPUTS
nA	nB	nY
L	L	H
L	H	H
H	L	H
H	H	L

NOTES:

H = HIGH voltage level

L = LOW voltage level

RECOMMENDED OPERATING CONDITIONS

SYMBOL	PARAMETER	CONDITIONS	LIMITS		UNIT
			MIN	MAX	
V_{CC}	DC supply voltage (for max. speed performance)		2.7	3.6	V
V_{CC}	DC supply voltage (for low-voltage applications)		1.2	3.6	V
V_I	DC Input voltage range		0	5.5	V
V_O	DC output voltage range		0	V_{CC}	V
T_{amb}	Operating ambient temperature range in free-air		-40	+85	°C
t_r, t_f	Input rise and fall times	$V_{CC} = 1.2$ to 2.7V $V_{CC} = 2.7$ to 3.6V	0	20 10	ns/V

ABSOLUTE MAXIMUM RATINGS¹

Absolute Maximum Rating System (IEC 134)

Voltages are referenced to GND (ground = 0V)

SYMBOL	PARAMETER	CONDITIONS	RATING	UNIT
V_{CC}	DC supply voltage (for max. speed performance)		-0.5 to +6.5	V
I_{IK}	DC input diode current	$V_I < 0$	-50	mA
V_I	DC input voltage	Note 2	-0.5 to +5.5	V
I_{OK}	DC output diode current	$V_O > V_{CC}$ or $V_O < 0$	±50	mA
V_O	DC output voltage	Note 2	-0.5 to $V_{CC} + 0.5$	V
I_O	DC output source or sink current	$V_O = 0$ to V_{CC}	±50	mA
I_{GND}, I_{CC}	DC V_{CC} or GND current		±100	mA
T_{stg}	Storage temperature range		-65 to +150	°C
P_{TOT}	Power dissipation per package – plastic mini-pack (SO) – plastic shrink mini-pack (SSOP and TSSOP)	above +70°C derate linearly with 8 mW/K above +60°C derate linearly with 5.5 mW/K	500 500	mW

NOTES:

- Stresses beyond those listed may cause permanent damage to the device. These are stress ratings only and functional operation of the device at these or any other conditions beyond those indicated under "recommended operating conditions" is not implied. Exposure to absolute-maximum-rated conditions for extended periods may affect device reliability.
- The input and output voltage ratings may be exceeded if the input and output current ratings are observed.

Quad 2-input NAND gate

74LVC00A

DC CHARACTERISTICS

Over recommended operating conditions voltages are referenced to GND (ground = 0V)

SYMBOL	PARAMETER	TEST CONDITIONS	LIMITS			UNIT
			Temp = -40°C to +85°C			
			MIN	TYP ¹	MAX	
V _{IH}	HIGH level Input voltage	V _{CC} = 1.2V	V _{CC}			V
		V _{CC} = 2.7 to 3.6V	2.0			
V _{IL}	LOW level Input voltage	V _{CC} = 1.2V			GND	V
		V _{CC} = 2.7 to 3.6V			0.8	
V _{OH}	HIGH level output voltage	V _{CC} = 2.7V; V _I = V _{IH} or V _{IL} ; I _O = -12mA	V _{CC} - 0.5			V
		V _{CC} = 3.0V; V _I = V _{IH} or V _{IL} ; I _O = -100µA	V _{CC} - 0.2	V _{CC}		
		V _{CC} = 3.0V; V _I = V _{IH} or V _{IL} ; I _O = -18mA	V _{CC} - 0.6			
		V _{CC} = 3.0V; V _I = V _{IH} or V _{IL} ; I _O = -24mA	V _{CC} - 0.8			
V _{OL}	LOW level output voltage	V _{CC} = 2.7V; V _I = V _{IH} or V _{IL} ; I _O = 12mA			0.40	V
		V _{CC} = 3.0V; V _I = V _{IH} or V _{IL} ; I _O = 100µA			0.20	
		V _{CC} = 3.0V; V _I = V _{IH} or V _{IL} ; I _O = 24mA			0.55	
I _I	Input leakage current	V _{CC} = 3.6V; V _I = 5.5V or GND		±0.1	±5	µA
I _{CC}	Quiescent supply current	V _{CC} = 3.6V; V _I = V _{CC} or GND; I _O = 0		0.1	10	µA
ΔI _{CC}	Additional quiescent supply current per input pin	V _{CC} = 2.7V to 3.6V; V _I = V _{CC} - 0.6V; I _O = 0		5	500	µA

NOTES:

1. All typical values are at V_{CC} = 3.3V and T_{amb} = 25°C.

AC CHARACTERISTICS

GND = 0 V; t_r = t_f ≤ 2.5 ns; C_L = 50 pF

SYMBOL	PARAMETER	WAVEFORM	LIMITS							UNIT
			V _{CC} = 3.3V ±0.3V			V _{CC} = 2.7V			V _{CC} = 1.2V	
			MIN	TYP ¹	MAX	MIN	TYP	MAX	TYP	
t _{PHL} / t _{PLH}	Propagation delay nA, nB to nY	1, 2	1.5	3.0	5.0	1.5	3.4	5.8	11	ns

NOTE:

1. These typical values are at V_{CC} = 3.3V and T_{amb} = 25°C.

AC WAVEFORMS

V_M = 1.5 V at V_{CC} ≥ 2.7 V

V_M = 0.5 • V_{CC} at V_{CC} < 2.7 V

V_{OL} and V_{OH} are the typical output voltage drop that occur with the output load.

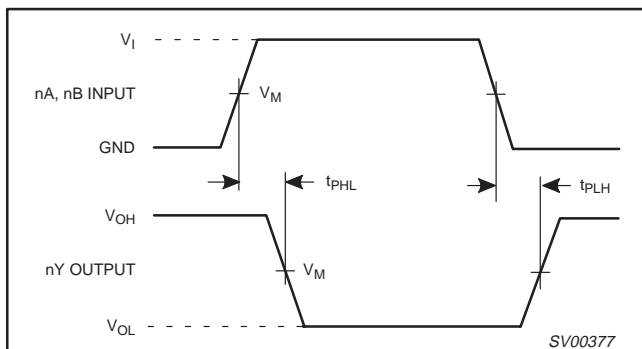

Waveform 1. Input (nA) to output (nY) propagation delays.

TEST CIRCUIT

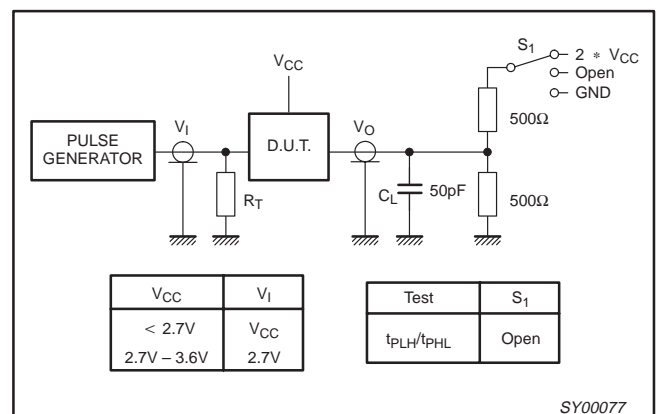

Waveform 2. Load circuitry for switching times.

Quad 2-input NAND gate

74LVC00A

SO14: plastic small outline package; 14 leads; body width 3.9 mm

SOT108-1

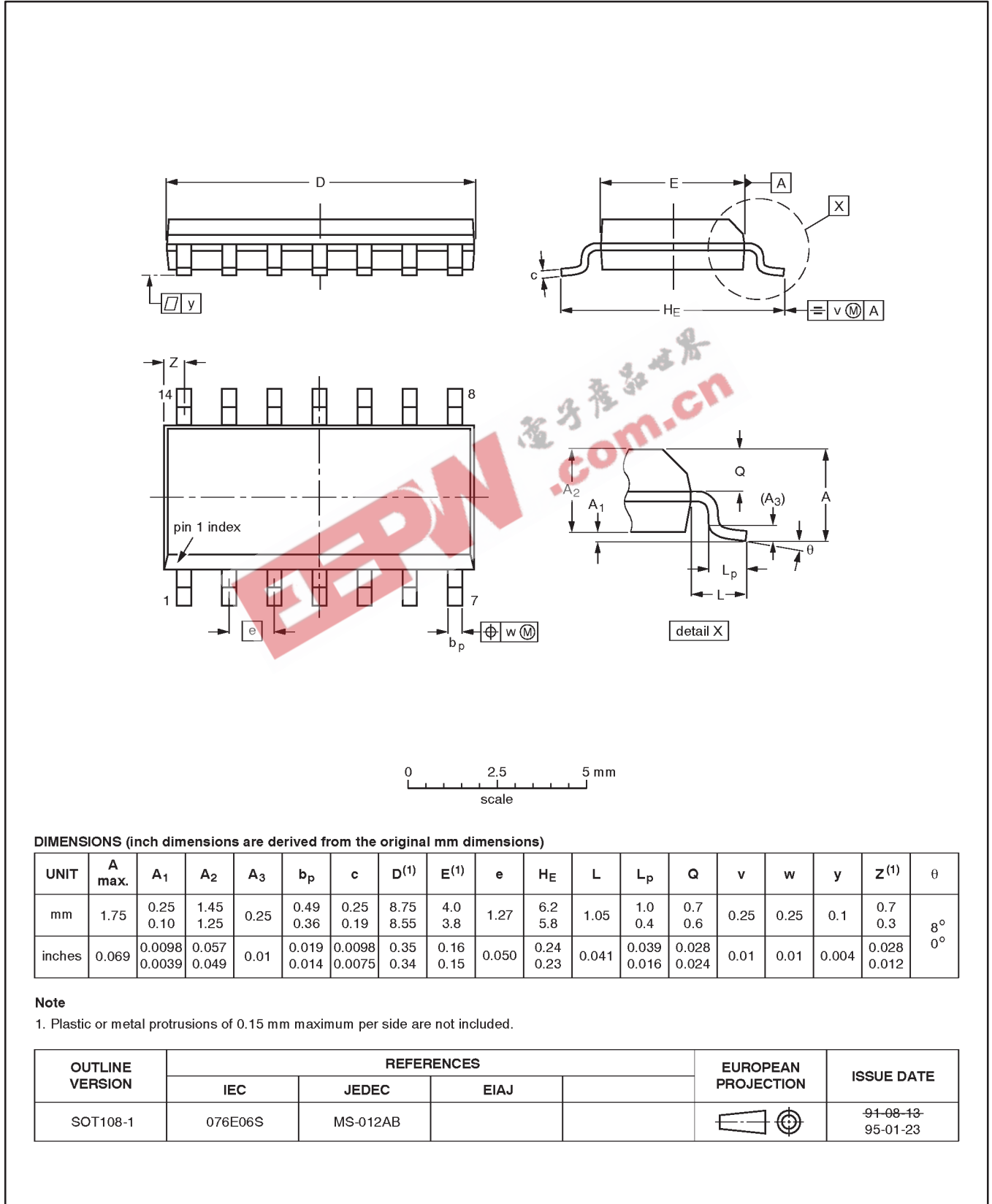

DIMENSIONS (inch dimensions are derived from the original mm dimensions)

UNIT	A max.	A ₁	A ₂	A ₃	b _p	c	D ⁽¹⁾	E ⁽¹⁾	e	H _E	L	L _p	Q	v	w	y	z ⁽¹⁾	θ
mm	1.75	0.25 0.10	1.45 1.25	0.25	0.49 0.36	0.25 0.19	8.75 8.55	4.0 3.8	1.27	6.2 5.8	1.05	1.0 0.4	0.7 0.6	0.25	0.25	0.1	0.7 0.3	8° 0°
inches	0.069	0.0098 0.0039	0.057 0.049	0.01	0.019 0.014	0.0098 0.0075	0.35 0.34	0.16 0.15	0.050	0.24 0.23	0.041	0.039 0.016	0.028 0.024	0.01	0.01	0.004	0.028 0.012	

Note

1. Plastic or metal protrusions of 0.15 mm maximum per side are not included.

OUTLINE VERSION	REFERENCES				EUROPEAN PROJECTION	ISSUE DATE
	IEC	JEDEC	EIAJ			
SOT108-1	076E06S	MS-012AB				91-08-13 95-01-23

Quad 2-input NAND gate

74LVC00A

SSOP14: plastic shrink small outline package; 14 leads; body width 5.3 mm

SOT337-1

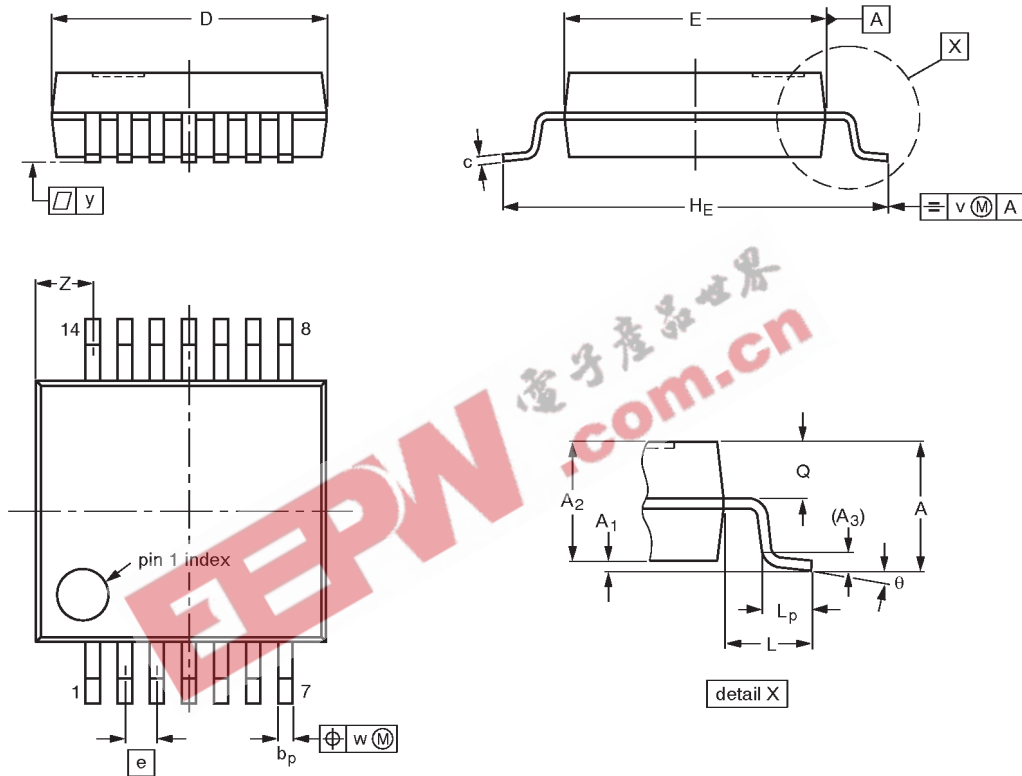

DIMENSIONS (mm are the original dimensions)

UNIT	A max.	A ₁	A ₂	A ₃	b _p	c	D ⁽¹⁾	E ⁽¹⁾	e	H _E	L	L _p	Q	v	w	y	Z ⁽¹⁾	θ
mm	2.0	0.21 0.05	1.80 1.65	0.25	0.38 0.25	0.20 0.09	6.4 6.0	5.4 5.2	0.65	7.9 7.6	1.25	1.03 0.63	0.9 0.7	0.2	0.13	0.1	1.4 0.9	8° 0°

Note

1. Plastic or metal protrusions of 0.25 mm maximum per side are not included.

OUTLINE VERSION	REFERENCES				EUROPEAN PROJECTION	ISSUE DATE
	IEC	JEDEC	EIAJ			
SOT337-1		MO-150AB				95-02-04 96-01-18

Quad 2-input NAND gate

74LVC00A

TSSOP14: plastic thin shrink small outline package; 14 leads; body width 4.4 mm

SOT402-1

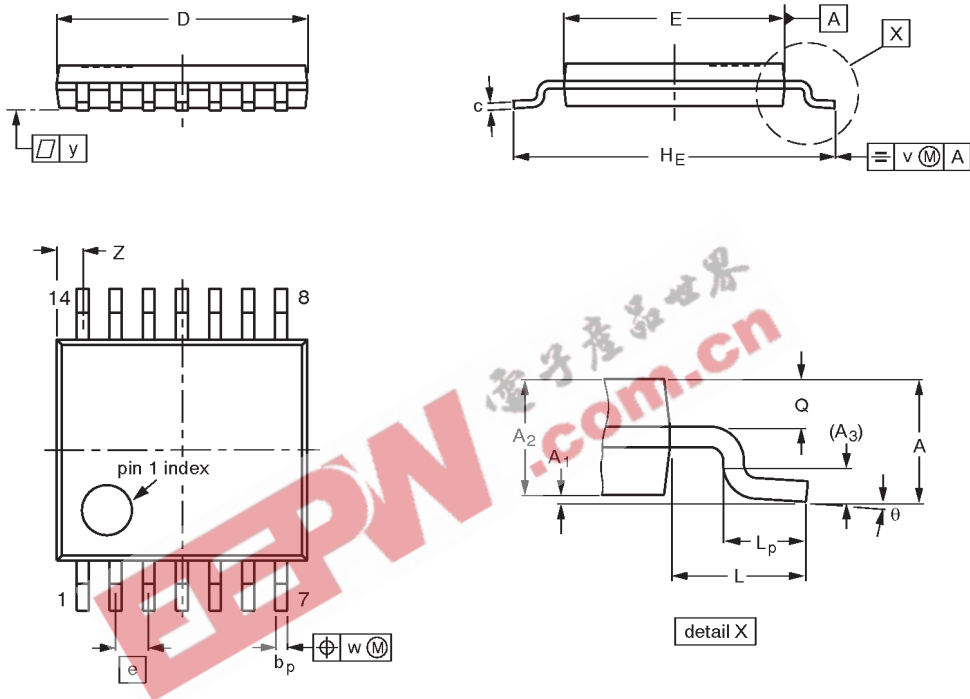

DIMENSIONS (mm are the original dimensions)

UNIT	A max.	A ₁	A ₂	A ₃	b _p	c	D ⁽¹⁾	E ⁽²⁾	e	H _E	L	L _p	Q	v	w	y	Z ⁽¹⁾	θ
mm	1.10	0.15 0.05	0.95 0.80	0.25	0.30 0.19	0.2 0.1	5.1 4.9	4.5 4.3	0.65	6.6 6.2	1.0	0.75 0.50	0.4 0.3	0.2	0.13	0.1	0.72 0.38	8° 0°

Notes

1. Plastic or metal protrusions of 0.15 mm maximum per side are not included.
2. Plastic interlead protrusions of 0.25 mm maximum per side are not included.

OUTLINE VERSION	REFERENCES				EUROPEAN PROJECTION	ISSUE DATE
	IEC	JEDEC	EIAJ			
SOT402-1		MO-153				-94-07-12- 95-04-04

Quad 2-input NAND gate

74LVC00A

DEFINITIONS

Data Sheet Identification	Product Status	Definition
<i>Objective Specification</i>	Formative or in Design	This data sheet contains the design target or goal specifications for product development. Specifications may change in any manner without notice.
<i>Preliminary Specification</i>	Preproduction Product	This data sheet contains preliminary data, and supplementary data will be published at a later date. Philips Semiconductors reserves the right to make changes at any time without notice in order to improve design and supply the best possible product.
<i>Product Specification</i>	Full Production	This data sheet contains Final Specifications. Philips Semiconductors reserves the right to make changes at any time without notice, in order to improve design and supply the best possible product.

Philips Semiconductors and Philips Electronics North America Corporation reserve the right to make changes, without notice, in the products, including circuits, standard cells, and/or software, described or contained herein in order to improve design and/or performance. Philips Semiconductors assumes no responsibility or liability for the use of any of these products, conveys no license or title under any patent, copyright, or mask work right to these products, and makes no representations or warranties that these products are free from patent, copyright, or mask work right infringement, unless otherwise specified. Applications that are described herein for any of these products are for illustrative purposes only. Philips Semiconductors makes no representation or warranty that such applications will be suitable for the specified use without further testing or modification.

LIFE SUPPORT APPLICATIONS

Philips Semiconductors and Philips Electronics North America Corporation Products are not designed for use in life support appliances, devices, or systems where malfunction of a Philips Semiconductors and Philips Electronics North America Corporation Product can reasonably be expected to result in a personal injury. Philips Semiconductors and Philips Electronics North America Corporation customers using or selling Philips Semiconductors and Philips Electronics North America Corporation Products for use in such applications do so at their own risk and agree to fully indemnify Philips Semiconductors and Philips Electronics North America Corporation for any damages resulting from such improper use or sale.

Philips Semiconductors
811 East Arques Avenue
P.O. Box 3409
Sunnyvale, California 94088-3409
Telephone 800-234-7381

© Copyright Philips Electronics North America Corporation 1998
 All rights reserved. Printed in U.S.A.

print code

Date of release: 05-96

Document order number:

9397-750-04476

Let's make things better.