

DATA SHEET

EEPW 电子產品世界
.com.cn

74HC/HCT258

Quad 2-input multiplexer; 3-state;
inverting

Product specification
File under Integrated Circuits, IC06

1999 Sep 02

Quad 2-input multiplexer; 3-state; inverting

74HC/HCT258

FEATURES

- Inverting data path
- 3-state outputs interface directly with system bus
- Output capability: bus driver
- I_{CC} category: MSI.

GENERAL DESCRIPTION

The 74HC/HCT258 are high-speed Si-gate CMOS devices and are pin compatible with Low power Schottky TTL (LSTTL). They are specified in compliance with JEDEC standard no. 7A.

The 74HC/HCT258 have four identical 2-input multiplexers with 3-state outputs, which select 4 bits of data from two sources and are controlled by a common data select input (S).

The data inputs from source 0 (1I₀ to 4I₀) are selected when input S is LOW and the data inputs from source 1 (1I₁ to 4I₁) are selected when S is HIGH.

QUICK REFERENCE DATA

GND = 0 V; T_{amb} = 25 °C; t_r = t_f = 6 ns.

SYMBOL	PARAMETER	CONDITIONS	TYPICAL		UNIT
			HC	HCT	
t _{PHL} /t _{PLH}	propagation delay nI ₀ , nI ₁ to n \bar{Y} S to n \bar{Y}	C _L = 15 pF; V _{CC} = 5 V	9	13	ns
			14	16	ns
C _I	input capacitance		3.5	3.5	pF
C _{PD}	power dissipation capacitance per multiplexer	notes 1 and 2	55	38	pF

Notes

1. C_{PD} is used to determine the dynamic power dissipation (P_D in μW):
 $P_D = C_{PD} \times V_{CC}^2 \times f_i + \sum (C_L \times V_{CC}^2 \times f_o)$ where:
 f_i = input frequency in MHz;
 f_o = output frequency in MHz;
 $\sum (C_L \times V_{CC}^2 \times f_o)$ = sum of outputs;
 C_L = output load capacitance in pF;
 V_{CC} = supply voltage in Volts.
2. For HC the condition is V_I = GND to V_{CC};
 For HCT the condition is V_I = GND to V_{CC} - 1.5 V.

Data appears at the outputs (1 \bar{Y} to 4 \bar{Y}) in inverted form from the select inputs.

The '258' is the logic implementation of a 4-pole, 2-position switch, where the position of the switch is determined by the logic levels applied to S. The outputs are forced to a high impedance OFF-state when \overline{OE} is HIGH.

The logic equations for the outputs are:

$$1\bar{Y} = \overline{\overline{OE} \times (1I_1 \times S + 1I_0 \times \bar{S})}$$

$$2\bar{Y} = \overline{\overline{OE} \times (2I_1 \times S + 2I_0 \times \bar{S})}$$

$$3\bar{Y} = \overline{\overline{OE} \times (3I_1 \times S + 3I_0 \times \bar{S})}$$

$$4\bar{Y} = \overline{\overline{OE} \times (4I_1 \times S + 4I_0 \times \bar{S})}$$

The '258' is identical to the '257' but has inverting outputs.

Quad 2-input multiplexer; 3-state; inverting

74HC/HCT258

ORDERING INFORMATION

TYPE NUMBER	PACKAGE		
	NAME	DESCRIPTION	VERSION
74HC258N; 74HCT258N	DIP16	plastic dual in-line package; 16 leads (300 mil); long body	SOT38-1
74HC258D; 74HCT258D	SO16	plastic small outline package; 16 leads; body width 3.9 mm	SOT109-1
74HC258DB	SSOP16	plastic shrink small outline package; 16 leads; body width 5.3 mm	SOT338-1

PIN DESCRIPTION

PIN NO.	SYMBOL	NAME AND FUNCTION
1	S	common data select input
2, 5, 11 and 14	1I ₀ to 4I ₀	data inputs from source 0
3, 6, 10 and 13	1I ₁ to 4I ₁	data inputs from source 1
4, 7, 9 and 12	1Ȳ to 4Ȳ	3-state multiplexer outputs
8	GND	ground (0 V)
15	OĒ	3-state output enable input (active LOW)
16	V _{CC}	positive supply voltage

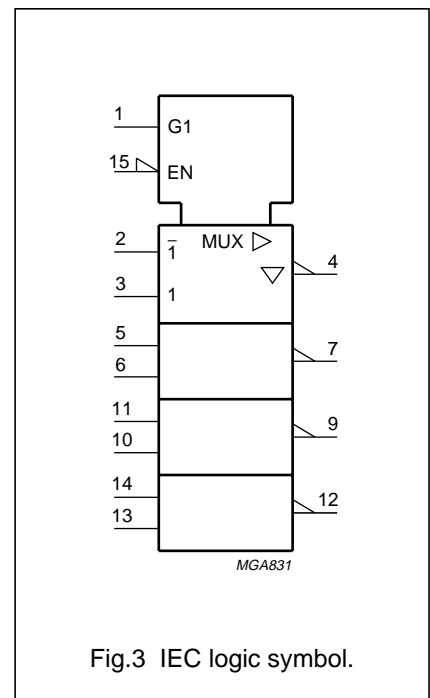
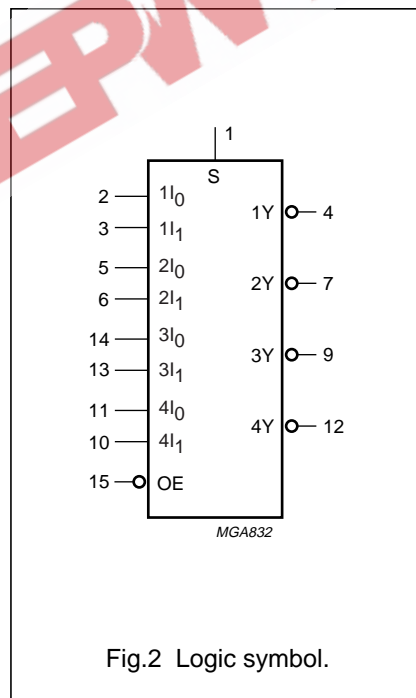
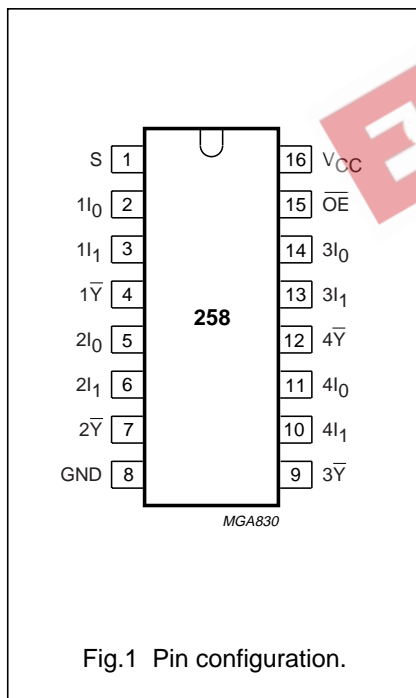

Quad 2-input multiplexer; 3-state; inverting

74HC/HCT258

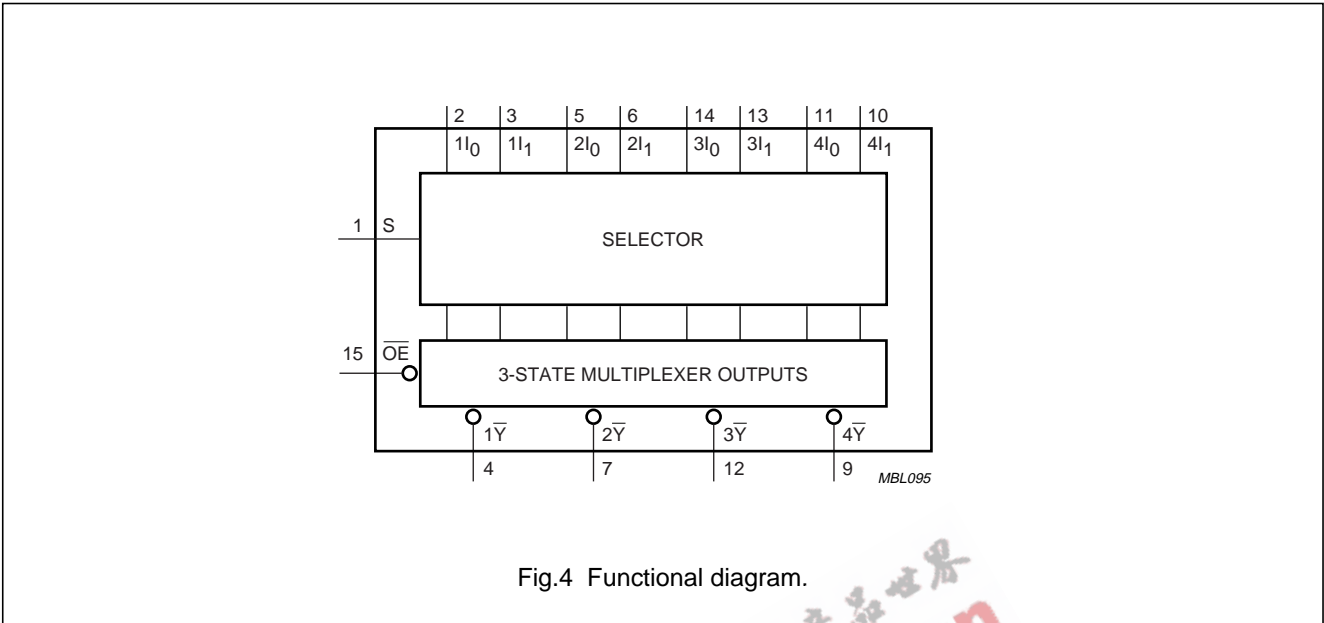

Fig.4 Functional diagram.

FUNCTION TABLE

See note 1

INPUTS				OUTPUT
OE	S	nI ₀	nI ₁	nY
H	X	X	X	Z
L	H	X	L	H
L	H	X	H	L
L	L	L	X	H
L	L	H	X	L

Note

1. H = HIGH voltage level;
 L = LOW voltage level;
 X = don't care;
 Z = high impedance OFF-state.

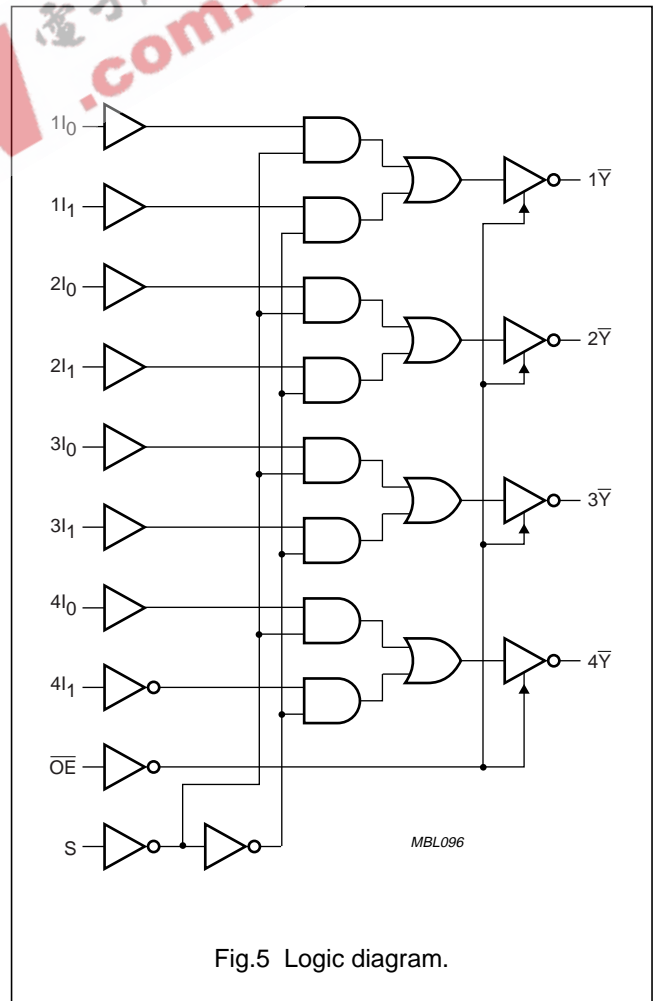

Fig.5 Logic diagram.

Quad 2-input multiplexer; 3-state; inverting

74HC/HCT258

DC CHARACTERISTICS FOR 74HC

For the DC characteristics see chapter "HCMOS family characteristics", section "Family specifications".

Output capability: bus driver.

I_{CC} category: MSI.

AC CHARACTERISTICS FOR 74HC

GND = 0 V; t_r = t_f = 6 ns; C_L = 50 pF.

SYMBOL	PARAMETER	T _{amb} (°C)						UNIT	TEST CONDITIONS		
		25			-40 to +85		-40 to +125		V _{CC} (V)	WAVEFORMS	
		MIN.	TYP.	MAX.	MIN.	MAX.	MIN.				MAX.
t _{PHL} /t _{PLH}	propagation delay; nI ₀ to n \bar{Y} ; nI ₁ to n \bar{Y}	-	30	95	-	120	-	145	ns	2.0	see Fig.6
		-	11	19	-	24	-	29		4.5	
		-	9	16	-	20	-	25		6.0	
	propagation delay; S to n \bar{Y}	-	47	140	-	175	-	210	ns	2.0	see Fig.6
		-	17	28	-	35	-	42		4.5	
		-	14	24	-	30	-	36		6.0	
t _{PZH} /t _{PZL}	3-state output enable time OE to n \bar{Y}	-	39	140	-	175	-	210	ns	2.0	see Fig.7
		-	14	28	-	35	-	42		4.5	
		-	11	24	-	30	-	36		6.0	
t _{PHZ} /t _{PLZ}	3-state output disable time OE to n \bar{Y}	-	55	150	-	190	-	225	ns	2.0	see Fig.7
		-	20	30	-	38	-	45		4.5	
		-	16	26	-	33	-	38		6.0	
t _{THL} /t _{TLH}	output transition time	-	14	60	-	75	-	90	ns	2.0	see Fig.6
		-	5	12	-	15	-	18		4.5	
		-	4	10	-	13	-	15		6.0	

Quad 2-input multiplexer; 3-state; inverting

74HC/HCT258

DC CHARACTERISTICS FOR 74HCT

For the DC characteristics see chapter "HCMOS family characteristics", section "Family specifications".

Output capability: bus driver.

I_{CC} category: MSI.

Note to HCT types

The value of additional quiescent supply current (ΔI_{CC}) for a unit load of 1 is given in the family specifications.

To determine ΔI_{CC} per input, multiply this value by the unit load coefficient shown in Table 1.

Table 1

INPUT	UNIT LOAD COEFFICIENT
nI ₀	0.50
nI ₁	0.50
\overline{OE}	1.50
S	1.50

AC CHARACTERISTICS FOR 74HCT

GND = 0 V; t_r = t_f = 6 ns; C_L = 50 pF.

SYMBOL	PARAMETER	T _{amb} (°C)							UNIT	TEST CONDITIONS	
		25			-40 to +85		-40 to +125			V _{CC} (V)	WAVEFORMS
		MIN.	TYP.	MAX.	MIN.	MAX.	MIN.	MAX.			
t _{PHL} /t _{PLH}	propagation delay; nI ₀ to n \overline{Y} ; nI ₁ to n \overline{Y}	–	16	27	–	34	–	41	ns	4.5	see Fig.6
	propagation delay; S to n \overline{Y}	–	19	34	–	43	–	51	ns	4.5	see Fig.6
t _{PZH} /t _{PZL}	3-state output enable time; \overline{OE} to n \overline{Y}	–	18	30	–	38	–	45	ns	4.5	see Fig.7
t _{PHZ} /t _{PLZ}	3-state output disable time; \overline{OE} to n \overline{Y}	–	17	30	–	38	–	45	ns	4.5	see Fig.7
t _{THL} /t _{TLH}	output transition time	–	5	12	–	15	–	18	ns	4.5	see Fig.6

Quad 2-input multiplexer; 3-state; inverting

74HC/HCT258

AC WAVEFORMS

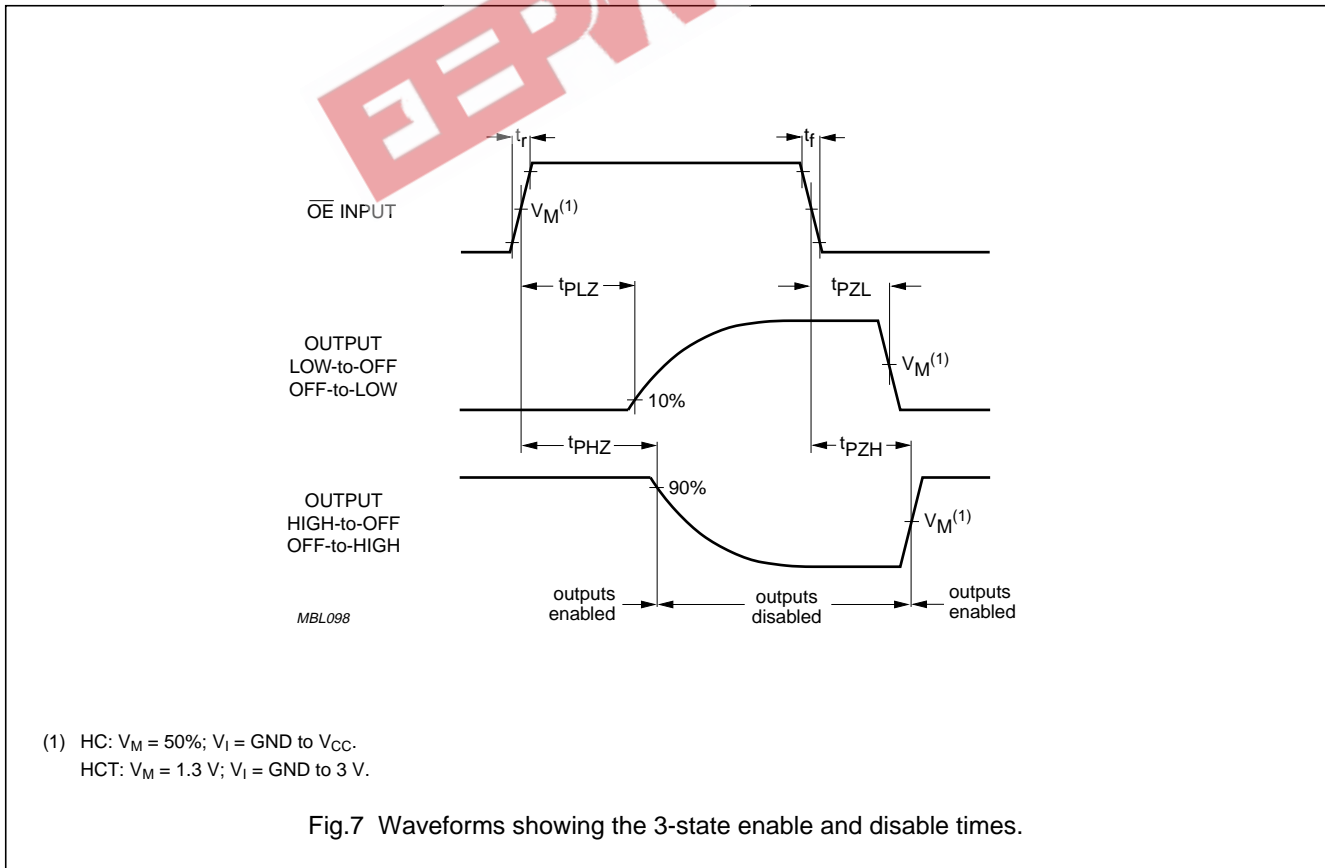
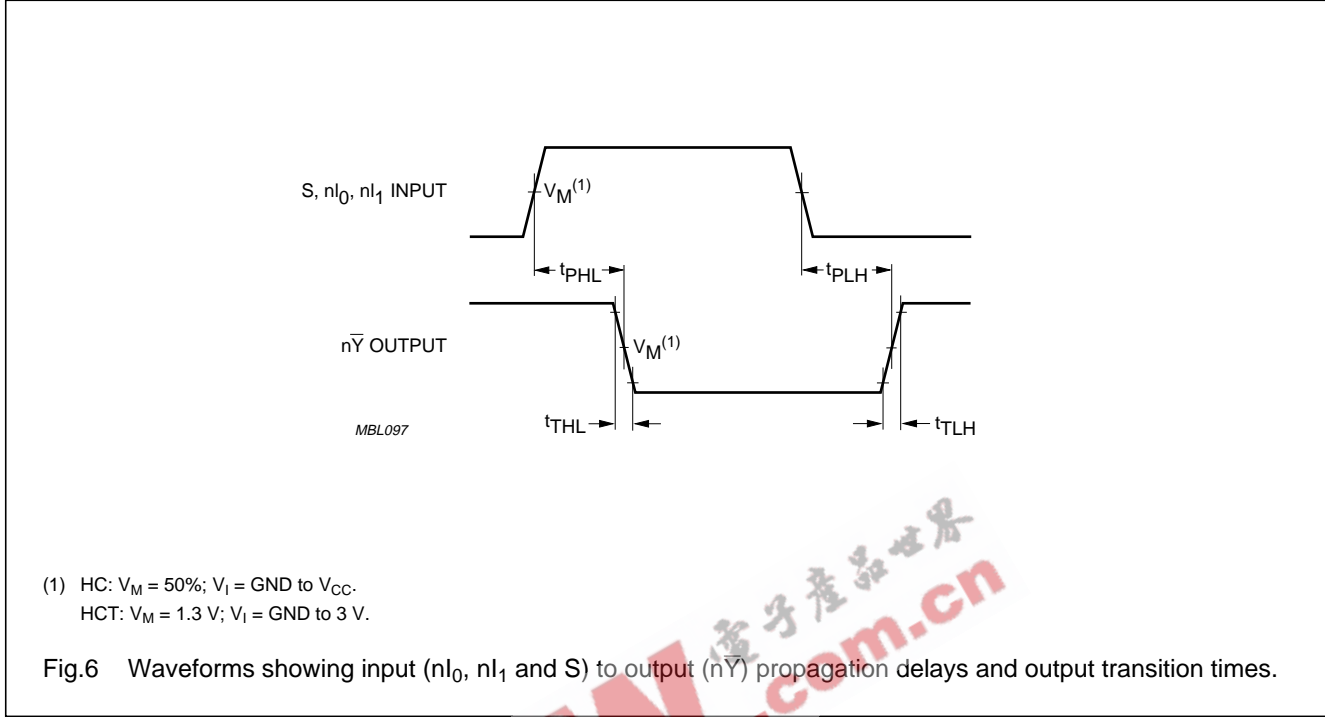

Quad 2-input multiplexer; 3-state; inverting

74HC/HCT258

PACKAGE OUTLINES

DIP16: plastic dual in-line package; 16 leads (300 mil); long body

SOT38-1

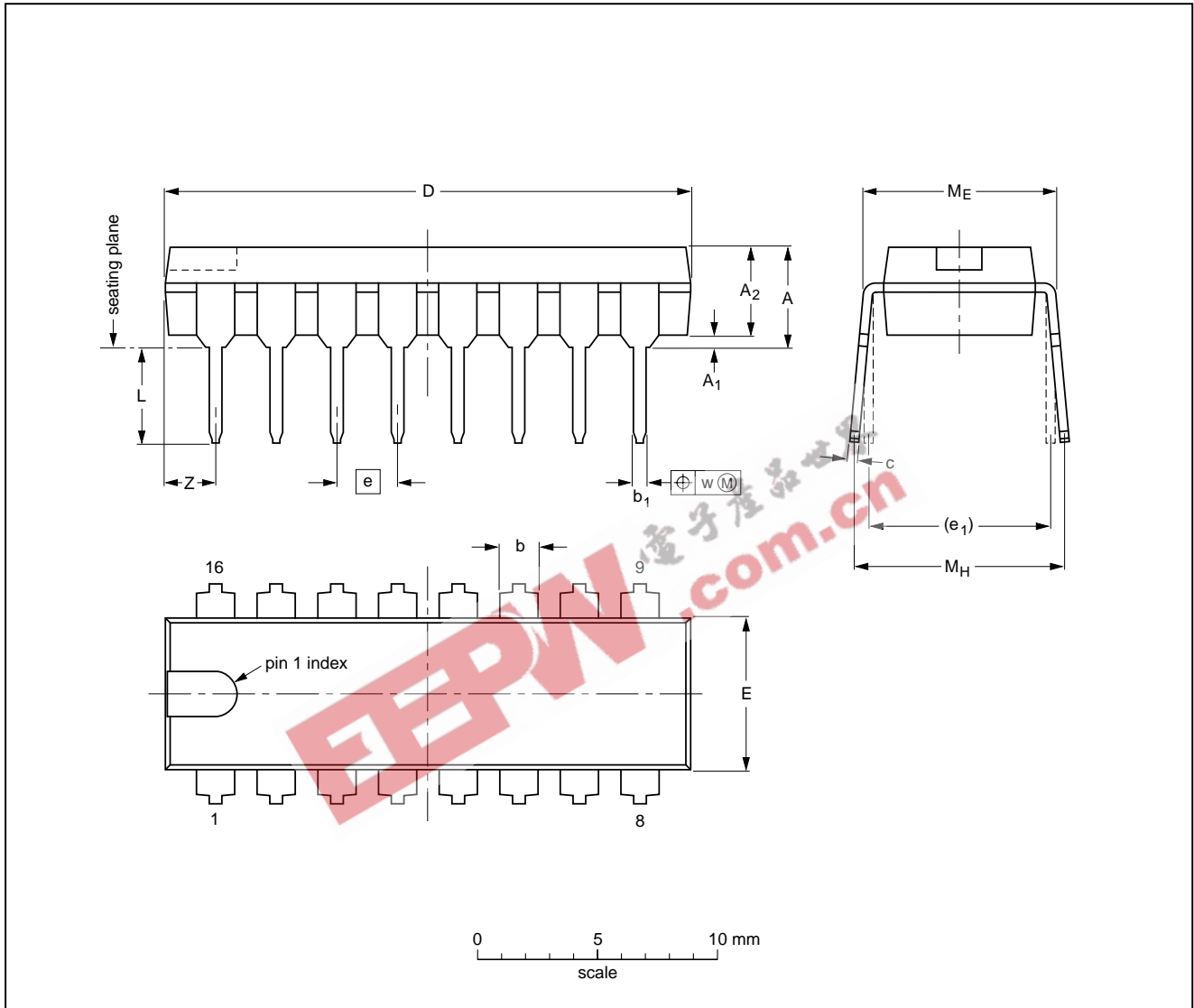

DIMENSIONS (inch dimensions are derived from the original mm dimensions)

UNIT	A max.	A ₁ min.	A ₂ max.	b	b ₁	c	D ⁽¹⁾	E ⁽¹⁾	e	e ₁	L	M _E	M _H	w	Z ⁽¹⁾ max.
mm	4.7	0.51	3.7	1.40 1.14	0.53 0.38	0.32 0.23	21.8 21.4	6.48 6.20	2.54	7.62	3.9 3.4	8.25 7.80	9.5 8.3	0.254	2.2
inches	0.19	0.020	0.15	0.055 0.045	0.021 0.015	0.013 0.009	0.86 0.84	0.26 0.24	0.10	0.30	0.15 0.13	0.32 0.31	0.37 0.33	0.01	0.087

Note

1. Plastic or metal protrusions of 0.25 mm maximum per side are not included.

OUTLINE VERSION	REFERENCES				EUROPEAN PROJECTION	ISSUE DATE
	IEC	JEDEC	EIAJ			
SOT38-1	050G09	MO-001AE				92-10-02 95-01-19

Quad 2-input multiplexer; 3-state; inverting

74HC/HCT258

SO16: plastic small outline package; 16 leads; body width 3.9 mm

SOT109-1

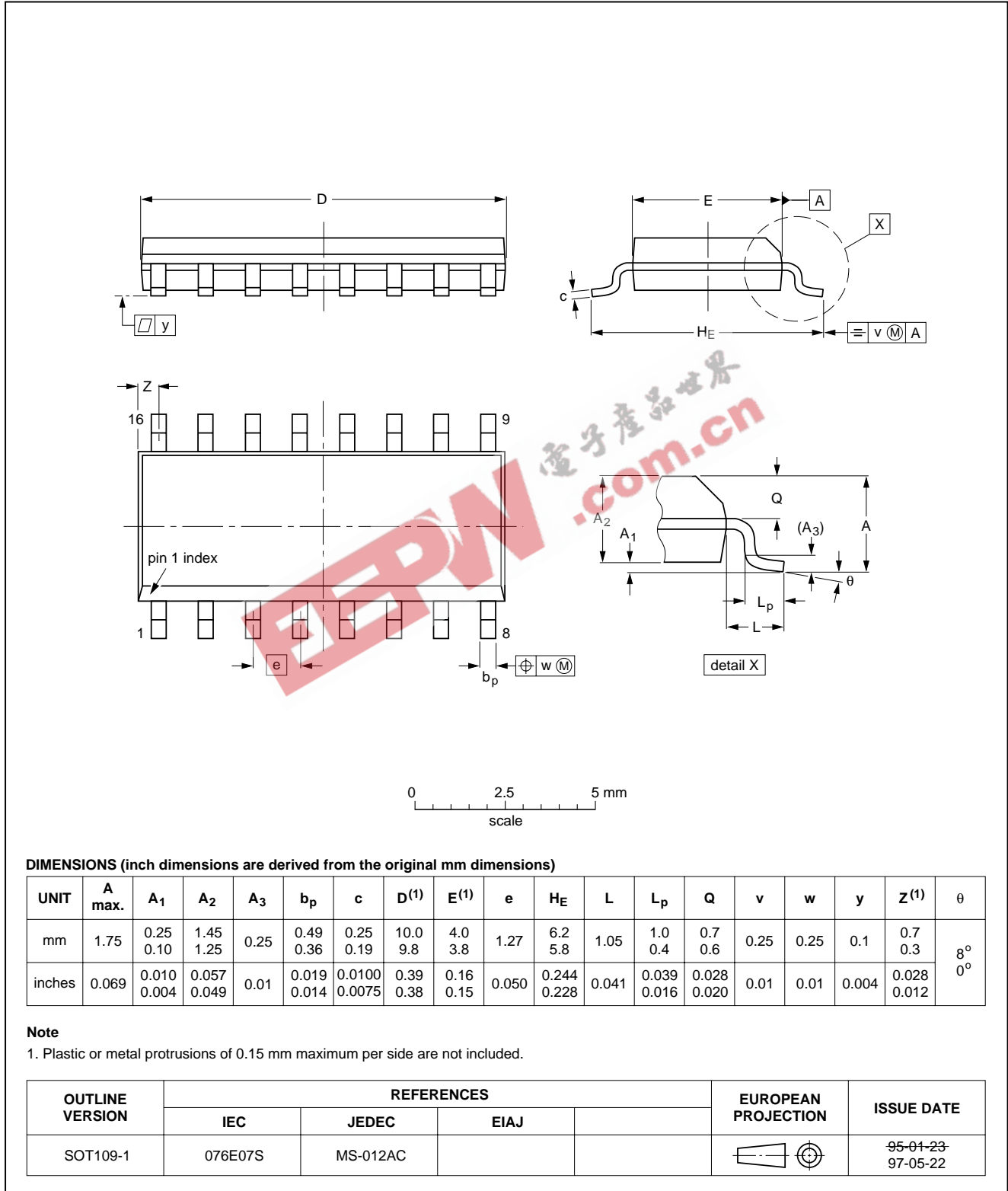

Quad 2-input multiplexer; 3-state; inverting

74HC/HCT258

SSOP16: plastic shrink small outline package; 16 leads; body width 5.3 mm

SOT338-1

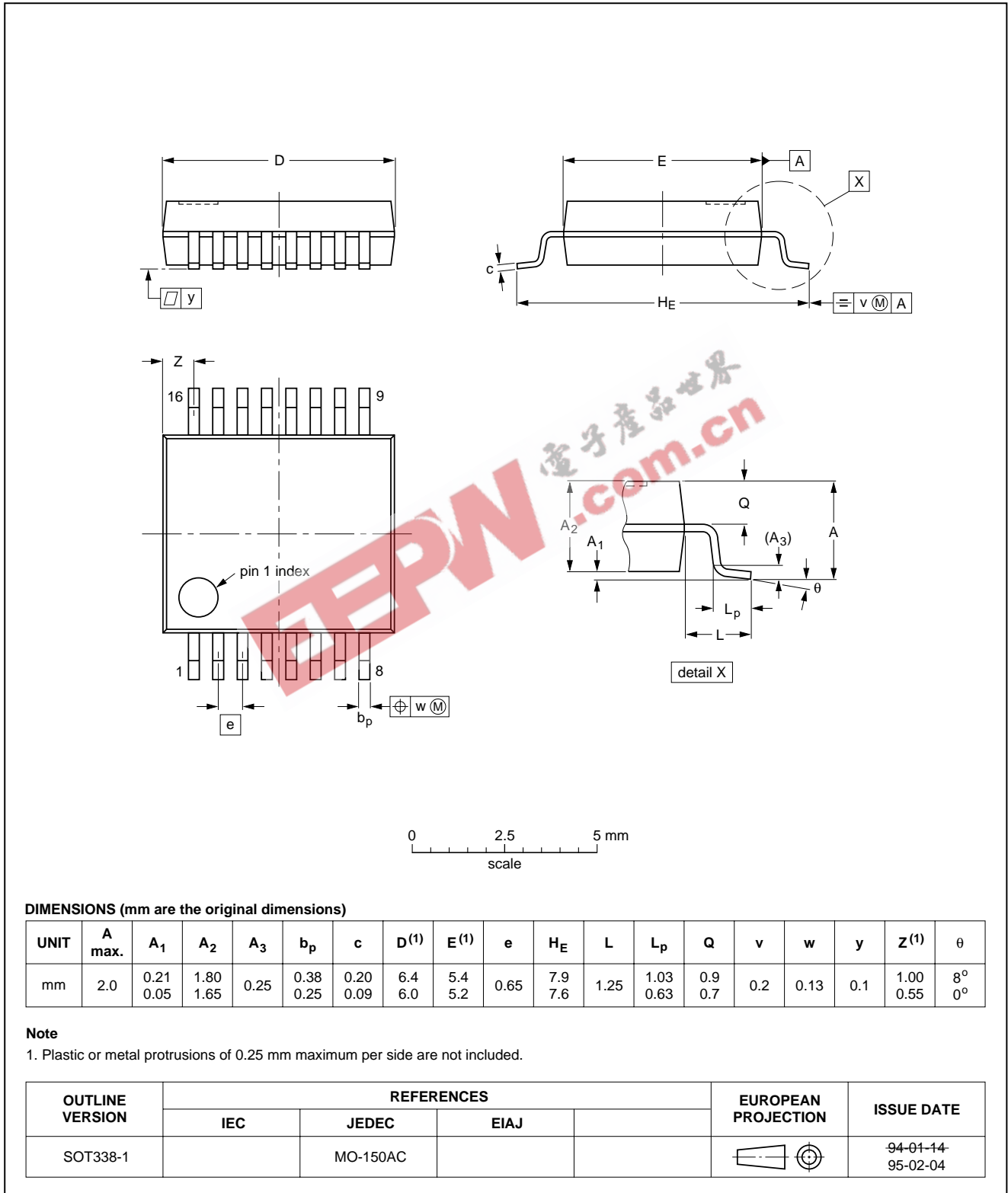

Quad 2-input multiplexer; 3-state; inverting

74HC/HCT258

SOLDERING**Introduction**

This text gives a very brief insight to a complex technology. A more in-depth account of soldering ICs can be found in our "Data Handbook IC26; Integrated Circuit Packages" (document order number 9398 652 90011).

There is no soldering method that is ideal for all IC packages. Wave soldering is often preferred when through-hole and surface mount components are mixed on one printed-circuit board. However, wave soldering is not always suitable for surface mount ICs, or for printed-circuit boards with high population densities. In these situations reflow soldering is often used.

Through-hole mount packages**SOLDERING BY DIPPING OR BY SOLDER WAVE**

The maximum permissible temperature of the solder is 260 °C; solder at this temperature must not be in contact with the joints for more than 5 seconds. The total contact time of successive solder waves must not exceed 5 seconds.

The device may be mounted up to the seating plane, but the temperature of the plastic body must not exceed the specified maximum storage temperature ($T_{stg(max)}$). If the printed-circuit board has been pre-heated, forced cooling may be necessary immediately after soldering to keep the temperature within the permissible limit.

MANUAL SOLDERING

Apply the soldering iron (24 V or less) to the lead(s) of the package, either below the seating plane or not more than 2 mm above it. If the temperature of the soldering iron bit is less than 300 °C it may remain in contact for up to 10 seconds. If the bit temperature is between 300 and 400 °C, contact may be up to 5 seconds.

Surface mount packages**REFLOW SOLDERING**

Reflow soldering requires solder paste (a suspension of fine solder particles, flux and binding agent) to be applied to the printed-circuit board by screen printing, stencilling or pressure-syringe dispensing before package placement.

Several methods exist for reflowing; for example, infrared/convection heating in a conveyor type oven. Throughput times (preheating, soldering and cooling) vary between 100 and 200 seconds depending on heating method.

Typical reflow peak temperatures range from 215 to 250 °C. The top-surface temperature of the packages should preferably be kept below 230 °C.

WAVE SOLDERING

Conventional single wave soldering is not recommended for surface mount devices (SMDs) or printed-circuit boards with a high component density, as solder bridging and non-wetting can present major problems.

To overcome these problems the double-wave soldering method was specifically developed.

If wave soldering is used the following conditions must be observed for optimal results:

- Use a double-wave soldering method comprising a turbulent wave with high upward pressure followed by a smooth laminar wave.
- For packages with leads on two sides and a pitch (e):
 - larger than or equal to 1.27 mm, the footprint longitudinal axis is **preferred** to be parallel to the transport direction of the printed-circuit board;
 - smaller than 1.27 mm, the footprint longitudinal axis **must** be parallel to the transport direction of the printed-circuit board.

The footprint must incorporate solder thieves at the downstream end.

- For packages with leads on four sides, the footprint must be placed at a 45° angle to the transport direction of the printed-circuit board. The footprint must incorporate solder thieves downstream and at the side corners.

During placement and before soldering, the package must be fixed with a droplet of adhesive. The adhesive can be applied by screen printing, pin transfer or syringe dispensing. The package can be soldered after the adhesive is cured.

Typical dwell time is 4 seconds at 250 °C.

A mildly-activated flux will eliminate the need for removal of corrosive residues in most applications.

MANUAL SOLDERING

Fix the component by first soldering two diagonally-opposite end leads. Use a low voltage (24 V or less) soldering iron applied to the flat part of the lead. Contact time must be limited to 10 seconds at up to 300 °C.

When using a dedicated tool, all other leads can be soldered in one operation within 2 to 5 seconds between 270 and 320 °C.

Quad 2-input multiplexer; 3-state; inverting

74HC/HCT258

Suitability of IC packages for wave, reflow and dipping soldering methods

MOUNTING	PACKAGE	SOLDERING METHOD		
		WAVE	REFLOW ⁽¹⁾	DIPPING
Through-hole mount	DBS, DIP, HDIP, SDIP, SIL	suitable ⁽²⁾	–	suitable
Surface mount	BGA, SQFP	not suitable	suitable	–
	HLQFP, HSQFP, HSOP, HTQFP, HTSSOP, SMS	not suitable ⁽³⁾	suitable	–
	PLCC ⁽⁴⁾ , SO, SOJ	suitable	suitable	–
	LQFP, QFP, TQFP	not recommended ⁽⁴⁾⁽⁵⁾	suitable	–
	SSOP, TSSOP, VSO	not recommended ⁽⁶⁾	suitable	–

Notes

- All surface mount (SMD) packages are moisture sensitive. Depending upon the moisture content, the maximum temperature (with respect to time) and body size of the package, there is a risk that internal or external package cracks may occur due to vaporization of the moisture in them (the so called popcorn effect). For details, refer to the Drypack information in the "Data Handbook IC26; Integrated Circuit Packages; Section: Packing Methods".
- For SDIP packages, the longitudinal axis must be parallel to the transport direction of the printed-circuit board.
- These packages are not suitable for wave soldering as a solder joint between the printed-circuit board and heatsink (at bottom version) can not be achieved, and as solder may stick to the heatsink (on top version).
- If wave soldering is considered, then the package must be placed at a 45° angle to the solder wave direction. The package footprint must incorporate solder thieves downstream and at the side corners.
- Wave soldering is only suitable for LQFP, QFP and TQFP packages with a pitch (e) equal to or larger than 0.8 mm; it is definitely not suitable for packages with a pitch (e) equal to or smaller than 0.65 mm.
- Wave soldering is only suitable for SSOP and TSSOP packages with a pitch (e) equal to or larger than 0.65 mm; it is definitely not suitable for packages with a pitch (e) equal to or smaller than 0.5 mm.

DEFINITIONS

Data sheet status	
Objective specification	This data sheet contains target or goal specifications for product development.
Preliminary specification	This data sheet contains preliminary data; supplementary data may be published later.
Product specification	This data sheet contains final product specifications.
Limiting values	
Limiting values given are in accordance with the Absolute Maximum Rating System (IEC 134). Stress above one or more of the limiting values may cause permanent damage to the device. These are stress ratings only and operation of the device at these or at any other conditions above those given in the Characteristics sections of the specification is not implied. Exposure to limiting values for extended periods may affect device reliability.	
Application information	
Where application information is given, it is advisory and does not form part of the specification.	

LIFE SUPPORT APPLICATIONS

These products are not designed for use in life support appliances, devices, or systems where malfunction of these products can reasonably be expected to result in personal injury. Philips customers using or selling these products for use in such applications do so at their own risk and agree to fully indemnify Philips for any damages resulting from such improper use or sale.

Quad 2-input multiplexer; 3-state; inverting

74HC/HCT258

NOTES



Quad 2-input multiplexer; 3-state; inverting

74HC/HCT258

NOTES



Quad 2-input multiplexer; 3-state; inverting

74HC/HCT258

NOTES



Philips Semiconductors – a worldwide company

Argentina: see South America

Australia: 3 Figtree Drive, HOMEBUSH, NSW 2140,
Tel. +61 2 9704 8141, Fax. +61 2 9704 8139

Austria: Computerstr. 6, A-1101 WIEN, P.O. Box 213,
Tel. +43 1 60 101 1248, Fax. +43 1 60 101 1210

Belarus: Hotel Minsk Business Center, Bld. 3, r. 1211, Volodarski Str. 6,
220050 MINSK, Tel. +375 172 20 0733, Fax. +375 172 20 0773

Belgium: see The Netherlands

Brazil: see South America

Bulgaria: Philips Bulgaria Ltd., Energoproject, 15th floor,
51 James Bourchier Blvd., 1407 SOFIA,
Tel. +359 2 68 9211, Fax. +359 2 68 9102

Canada: PHILIPS SEMICONDUCTORS/COMPONENTS,
Tel. +1 800 234 7381, Fax. +1 800 943 0087

China/Hong Kong: 501 Hong Kong Industrial Technology Centre,
72 Tat Chee Avenue, Kowloon Tong, HONG KONG,
Tel. +852 2319 7888, Fax. +852 2319 7700

Colombia: see South America

Czech Republic: see Austria

Denmark: Sydhavnsgade 23, 1780 COPENHAGEN V,
Tel. +45 33 29 3333, Fax. +45 33 29 3905

Finland: Sinikalliontie 3, FIN-02630 ESPOO,
Tel. +358 9 615 800, Fax. +358 9 6158 0920

France: 51 Rue Carnot, BP317, 92156 SURESNES Cedex,
Tel. +33 1 4099 6161, Fax. +33 1 4099 6427

Germany: Hammerbrookstraße 69, D-20097 HAMBURG,
Tel. +49 40 2353 60, Fax. +49 40 2353 6300

Hungary: see Austria

India: Philips INDIA Ltd, Band Box Building, 2nd floor,
254-D, Dr. Annie Besant Road, Worli, MUMBAI 400 025,
Tel. +91 22 493 8541, Fax. +91 22 493 0966

Indonesia: PT Philips Development Corporation, Semiconductors Division,
Gedung Philips, Jl. Buncit Raya Kav.99-100, JAKARTA 12510,
Tel. +62 21 794 0040 ext. 2501, Fax. +62 21 794 0080

Ireland: Newstead, Clonskeagh, DUBLIN 14,
Tel. +353 1 7640 000, Fax. +353 1 7640 200

Israel: RAPAC Electronics, 7 Kehilat Saloniki St, PO Box 18053,
TEL AVIV 61180, Tel. +972 3 645 0444, Fax. +972 3 649 1007

Italy: PHILIPS SEMICONDUCTORS, Via Casati, 23 - 20052 MONZA (MI),
Tel. +39 039 203 6838, Fax +39 039 203 6800

Japan: Philips Bldg 13-37, Kohnan 2-chome, Minato-ku,
TOKYO 108-8507, Tel. +81 3 3740 5130, Fax. +81 3 3740 5057

Korea: Philips House, 260-199 Itaewon-dong, Yongsan-ku, SEOUL,
Tel. +82 2 709 1412, Fax. +82 2 709 1415

Malaysia: No. 76 Jalan Universiti, 46200 PETALING JAYA, SELANGOR,
Tel. +60 3 750 5214, Fax. +60 3 757 4880

Mexico: 5900 Gateway East, Suite 200, EL PASO, TEXAS 79905,
Tel. +9-5 800 234 7381, Fax +9-5 800 943 0087

Middle East: see Italy

Netherlands: Postbus 90050, 5600 PB EINDHOVEN, Bldg. VB,
Tel. +31 40 27 82785, Fax. +31 40 27 88399

New Zealand: 2 Wagener Place, C.P.O. Box 1041, AUCKLAND,
Tel. +64 9 849 4160, Fax. +64 9 849 7811

Norway: Box 1, Manglerud 0612, OSLO,
Tel. +47 22 74 8000, Fax. +47 22 74 8341

Pakistan: see Singapore

Philippines: Philips Semiconductors Philippines Inc.,
106 Valero St. Salcedo Village, P.O. Box 2108 MCC, MAKATI,
Metro MANILA, Tel. +63 2 816 6380, Fax. +63 2 817 3474

Poland: Ul. Lukiska 10, PL 04-123 WARSZAWA,
Tel. +48 22 612 2831, Fax. +48 22 612 2327

Portugal: see Spain

Romania: see Italy

Russia: Philips Russia, Ul. Usatcheva 35A, 119048 MOSCOW,
Tel. +7 095 755 6918, Fax. +7 095 755 6919

Singapore: Lorong 1, Toa Payoh, SINGAPORE 319762,
Tel. +65 350 2538, Fax. +65 251 6500

Slovakia: see Austria

Slovenia: see Italy

South Africa: S.A. PHILIPS Pty Ltd., 195-215 Main Road Martindale,
2092 JOHANNESBURG, P.O. Box 58088 Newville 2114,
Tel. +27 11 471 5401, Fax. +27 11 471 5398

South America: Al. Vicente Pinzon, 173, 6th floor,
04547-130 SÃO PAULO, SP, Brazil,
Tel. +55 11 821 2333, Fax. +55 11 821 2382

Spain: Balmes 22, 08007 BARCELONA,
Tel. +34 93 301 6312, Fax. +34 93 301 4107

Sweden: Kottbygatan 7, Akalla, S-16485 STOCKHOLM,
Tel. +46 8 5985 2000, Fax. +46 8 5985 2745

Switzerland: Allmendstrasse 140, CH-8027 ZÜRICH,
Tel. +41 1 488 2741 Fax. +41 1 488 3263

Taiwan: Philips Semiconductors, 6F, No. 96, Chien Kuo N. Rd., Sec. 1,
TAIPEI, Taiwan Tel. +886 2 2134 2886, Fax. +886 2 2134 2874

Thailand: PHILIPS ELECTRONICS (THAILAND) Ltd.,
209/2 Sanpavuth-Bangna Road Prakanong, BANGKOK 10260,
Tel. +66 2 745 4090, Fax. +66 2 398 0793

Turkey: Yukari Dudullu, Org. San. Blg., 2.Cad. Nr. 28 81260 Umraniye,
ISTANBUL, Tel. +90 216 522 1500, Fax. +90 216 522 1813

Ukraine: PHILIPS UKRAINE, 4 Patrice Lumumba str., Building B, Floor 7,
252042 KIEV, Tel. +380 44 264 2776, Fax. +380 44 268 0461

United Kingdom: Philips Semiconductors Ltd., 276 Bath Road, Hayes,
MIDDLESEX UB3 5BX, Tel. +44 208 730 5000, Fax. +44 208 754 8421

United States: 811 East Arques Avenue, SUNNYVALE, CA 94088-3409,
Tel. +1 800 234 7381, Fax. +1 800 943 0087

Uruguay: see South America

Vietnam: see Singapore

Yugoslavia: PHILIPS, Trg N. Pasica 5/v, 11000 BEOGRAD,
Tel. +381 11 62 5344, Fax. +381 11 63 5777

For all other countries apply to: Philips Semiconductors,
International Marketing & Sales Communications, Building BE-p, P.O. Box 218,
5600 MD EINDHOVEN, The Netherlands, Fax. +31 40 27 24825

Internet: <http://www.semiconductors.philips.com>

© Philips Electronics N.V. 1999

SCA 67

All rights are reserved. Reproduction in whole or in part is prohibited without the prior written consent of the copyright owner.

The information presented in this document does not form part of any quotation or contract, is believed to be accurate and reliable and may be changed without notice. No liability will be accepted by the publisher for any consequence of its use. Publication thereof does not convey nor imply any license under patent- or other industrial or intellectual property rights.

Printed in The Netherlands

245002/02/pp16

Date of release: 1999 Sep 02

Document order number: 9397 750 06308

Let's make things better.

Philips
Semiconductors



PHILIPS