

DATA SHEET

For a complete data sheet, please also download:

- The IC06 74HC/HCT/HCU/HCMOS Logic Family Specifications
- The IC06 74HC/HCT/HCU/HCMOS Logic Package Information
- The IC06 74HC/HCT/HCU/HCMOS Logic Package Outlines

EEPW 电子产品世界
.com.cn

74HC/HCT4353

Triple 2-channel analog
multiplexer/demultiplexer with latch

Product specification
File under Integrated Circuits, IC06

December 1990

Triple 2-channel analog multiplexer/demultiplexer with latch

74HC/HCT4353

FEATURES

- Wide analog input voltage range: ± 5 V
- Low "ON" resistance:
 - 80 Ω (typ.) at $V_{CC} - V_{EE} = 4.5$ V
 - 70 Ω (typ.) at $V_{CC} - V_{EE} = 6.0$ V
 - 60 Ω (typ.) at $V_{CC} - V_{EE} = 9.0$ V
- Logic level translation: to enable 5 V logic to communicate with ± 5 V analog signals
- Typical "break before make" built in
- Address latches provided
- Output capability: non-standard
- I_{CC} category: MSI

GENERAL DESCRIPTION

The 74HC/HCT4353 are high-speed Si-gate CMOS devices. They are specified in compliance with JEDEC standard no. 7A.

The 74HC/HCT4353 are triple 2-channel analog multiplexers/demultiplexers with two common enable inputs (\bar{E}_1 and E_2) and a latch enable input (\bar{LE}). Each

multiplexer has two independent inputs/outputs (nY_0 and nY_1), a common input/output (nZ) and select inputs (S_1 to S_3).

Each multiplexer/demultiplexer contains two bidirectional analog switches, each with one side connected to an independent input/output (nY_0 and nY_1) and the other side connected to a common input/output (nZ).

With \bar{E}_1 LOW and E_2 HIGH, one of the two switches is selected (low impedance ON-state) by S_1 to S_3 . The data at the select inputs may be latched by using the active LOW latch enable input (\bar{LE}). When \bar{LE} is HIGH, the latch is transparent. When either of the two enable inputs, \bar{E}_1 (active LOW) and E_2 (active HIGH), is inactive, all analog switches are turned off.

V_{CC} and GND are the supply voltage pins for the digital control inputs (S_1 to S_3 , \bar{LE} , \bar{E}_1 and E_2). The V_{CC} to GND ranges are 2.0 to 10.0 V for HC and 4.5 to 5.5 V for HCT. The analog inputs/outputs (nY_0 and nY_1 , and nZ) can swing between V_{CC} as a positive limit and V_{EE} as a negative limit. $V_{CC} - V_{EE}$ may not exceed 10.0 V.

For operation as a digital multiplexer/demultiplexer, V_{EE} is connected to GND (typically ground).

QUICK REFERENCE DATA

$V_{EE} = GND = 0$ V; $T_{amb} = 25$ °C; $t_r = t_f = 6$ ns

SYMBOL	PARAMETER	CONDITIONS	TYPICAL		UNIT
			HC	HCT	
t_{PZH}/t_{PZL}	turn "ON" time \bar{E}_1 , E_2 or S_n to V_{OS}	$C_L = 50$ pF; $R_L = 1$ k Ω ;	29	21	ns
t_{PHZ}/t_{PLZ}	turn "OFF" time \bar{E}_1 , E_2 or S_n to V_{OS}	$V_{CC} = 5$ V	20	22	ns
C_I	input capacitance		3.5	3.5	pF
C_{PD}	power dissipation capacitance per switch	notes 1 and 2	23	23	pF
C_S	max. switch capacitance independent (Y) common (Z)		5	5	pF
			8	8	pF

Notes

- C_{PD} is used to determine the dynamic power dissipation (P_D in μ W):

$$P_D = C_{PD} \times V_{CC}^2 \times f_i + \sum \{(C_L + C_S) \times V_{CC}^2 \times f_o\}$$
 where:
 - f_i = input frequency in MHz
 - C_L = output load capacitance in pF
 - f_o = output frequency in MHz
 - C_S = max. switch capacitance in pF

$$\sum \{(C_L \times C_S) \times V_{CC}^2 \times f_o\} = \text{sum of outputs}$$

V_{CC} = supply voltage in V

- For HC the condition is $V_I = GND$ to V_{CC}
For HCT the condition is $V_I = GND$ to $V_{CC} - 1.5$ V

ORDERING INFORMATION

See "74HC/HCT/HCU/HCMOS Logic Package Information".

Triple 2-channel analog
multiplexer/demultiplexer with latch

74HC/HCT4353

PIN DESCRIPTION

PIN NO.	SYMBOL	NAME AND FUNCTION
2, 1	2Y ₀ , 2Y ₁	independent inputs/outputs
5	3Z	common input/output
6, 4	3Y ₀ , 3Y ₁	independent inputs/outputs
3, 14	n.c.	not connected
7	\bar{E}_1	enable input (active LOW)
8	E ₂	enable input (active HIGH)
9	V _{EE}	negative supply voltage
10	GND	ground (0 V)
11	$\bar{L}E$	latch enable input (active LOW)
15, 13, 12	S ₁ to S ₃	select inputs
16, 17	1Y ₀ , 1Y ₁	independent inputs/outputs
18	1Z	common input/output
19	2Z	common input/output
20	V _{CC}	positive supply voltage

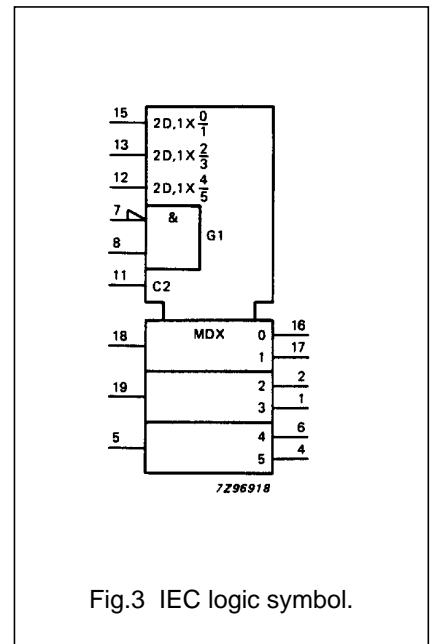
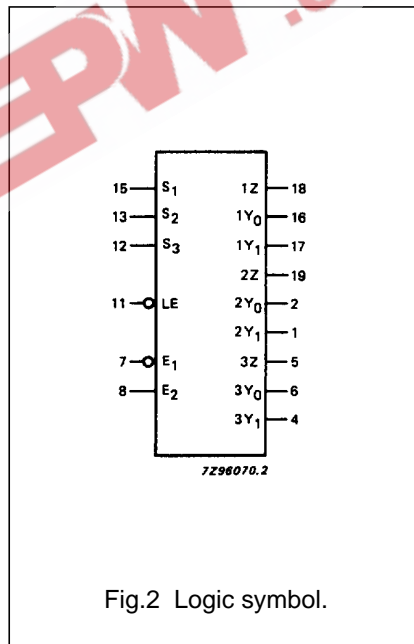
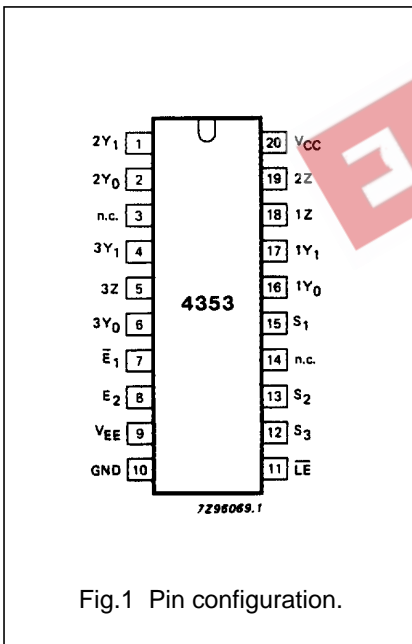

Triple 2-channel analog multiplexer/demultiplexer with latch

74HC/HCT4353

FUNCTION TABLE

INPUTS				CHANNEL ON
\bar{E}_1	E_2	\bar{LE}	S_n	
H	H	X	X	none
X	L	X	X	none
L	H	H	L	$nY_0 - nZ$
L	H	H	H	$nY_1 - nZ$
L	H	L	X	(1)
X	X	↓	X	(2)

Notes

1. Last selected channel "ON".
2. Selected channels latched.

H = HIGH voltage level
 L = LOW voltage level
 X = don't care
 ↓ = HIGH-to-LOW \bar{LE} transition

APPLICATIONS

- Analog multiplexing and demultiplexing
- Digital multiplexing and demultiplexing
- Signal gating

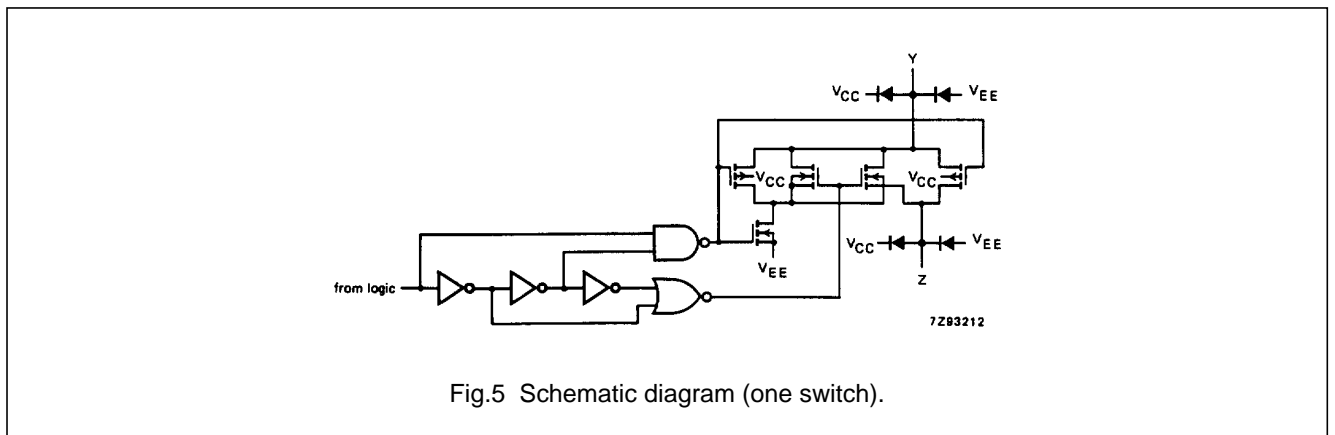
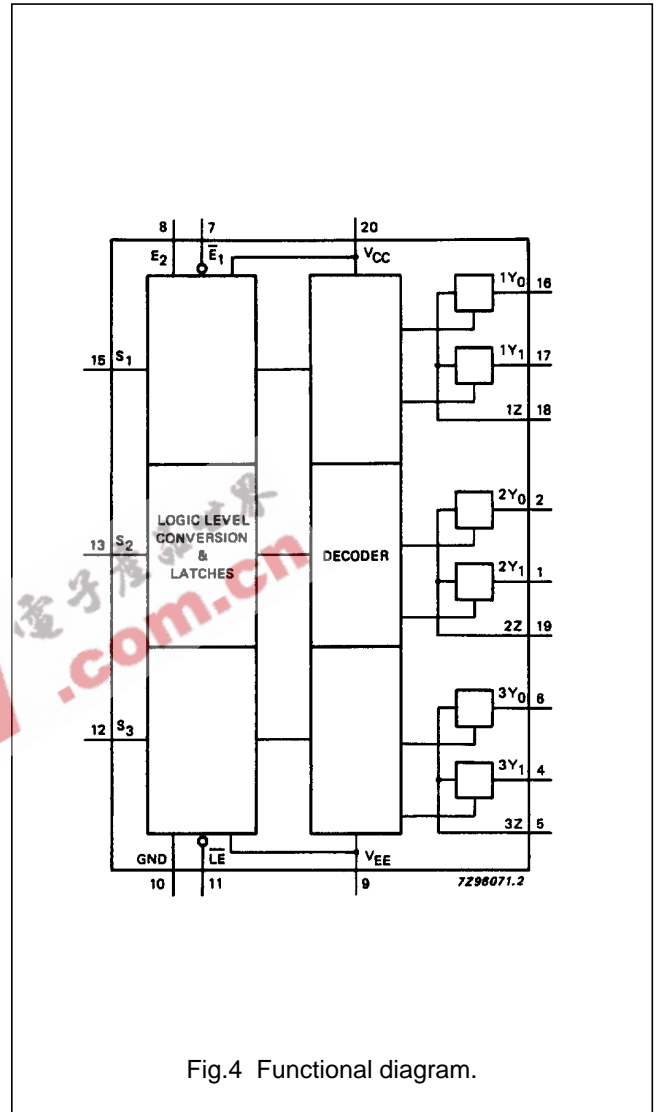

Triple 2-channel analog multiplexer/demultiplexer with latch

74HC/HCT4353

RATINGS

Limiting values in accordance with the Absolute Maximum System (IEC 134)

Voltages are referenced to $V_{EE} = \text{GND}$ (ground = 0 V)

SYMBOL	PARAMETER	MIN.	MAX.	UNIT	CONDITIONS
V_{CC}	DC supply voltage	-0.5	+11.0	V	
$\pm I_{IK}$	DC digital input diode current		20	mA	for $V_I < -0.5 \text{ V}$ or $V_I > V_{CC} + 0.5 \text{ V}$
$\pm I_{SK}$	DC switch diode current		20	mA	for $V_S < -0.5 \text{ V}$ or $V_S > V_{CC} + 0.5 \text{ V}$
$\pm I_S$	DC switch current		25	mA	for $-0.5 \text{ V} < V_S < V_{CC} + 0.5 \text{ V}$
$\pm I_{EE}$	DC V_{EE} current		20	mA	
$\pm I_{CC}$; $\pm I_{GND}$	DC V_{CC} or GND current		50	mA	
T_{stg}	storage temperature range	-65	+150	°C	
P_{tot}	power dissipation per package				for temperature range: -40 to +125 °C 74HC/HCT
	plastic DIL		750	mW	above +70 °C: derate linearly with 12 mW/K
	plastic mini-pack (SO)		500	mW	above +70 °C: derate linearly with 8 mW/K
P_S	power dissipation per switch		100	mW	

Note to ratings

- To avoid drawing V_{CC} current out of terminals nZ, when switch current flows in terminals nY_n, the voltage drop across the bidirectional switch must not exceed 0.4 V. If the switch current flows into terminals nZ, no V_{CC} current will flow out of terminals nY_n. In this case there is no limit for the voltage drop across the switch, but the voltages at nY_n and nZ may not exceed V_{CC} or V_{EE} .

RECOMMENDED OPERATING CONDITIONS

SYMBOL	PARAMETER	74HC			74HCT			UNIT	CONDITIONS
		min.	typ.	max.	min.	typ.	max.		
V_{CC}	DC supply voltage $V_{CC}-\text{GND}$	2.0	5.0	10.0	4.5	5.0	5.5	V	see Figs 6 and 7
V_{CC}	DC supply voltage $V_{CC}-V_{EE}$	2.0	5.0	10.0	2.0	5.0	10.0	V	see Figs 6 and 7
V_I	DC input voltage range	GND		V_{CC}	GND		V_{CC}	V	
V_S	DC switch voltage range	V_{EE}		V_{CC}	V_{EE}		V_{CC}	V	
T_{amb}	operating ambient temperature range	-40		+85	-40		+85	°C	see DC and AC CHARACTER- ISTICS
T_{amb}	operating ambient temperature range	-40		+125	-40		+125	°C	
t_r, t_f	input rise and fall times		6.0	1000 500 400 250		6.0	500	ns	$V_{CC} = 2.0 \text{ V}$ $V_{CC} = 4.5 \text{ V}$ $V_{CC} = 6.0 \text{ V}$ $V_{CC} = 10.0 \text{ V}$

Triple 2-channel analog multiplexer/demultiplexer with latch

74HC/HCT4353

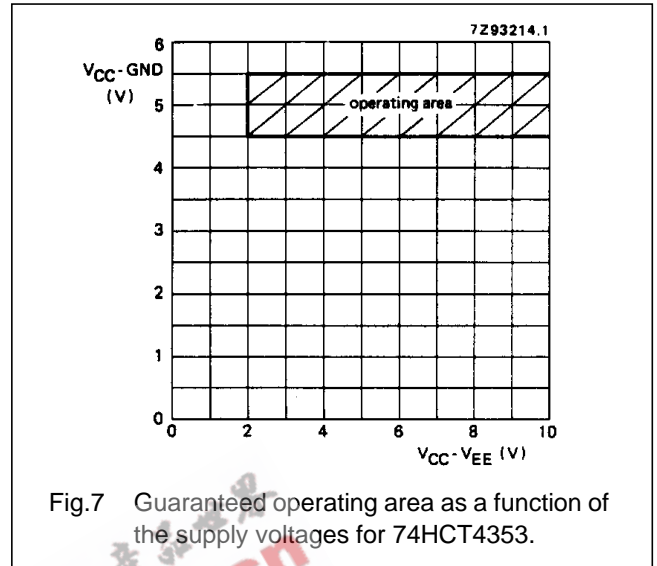
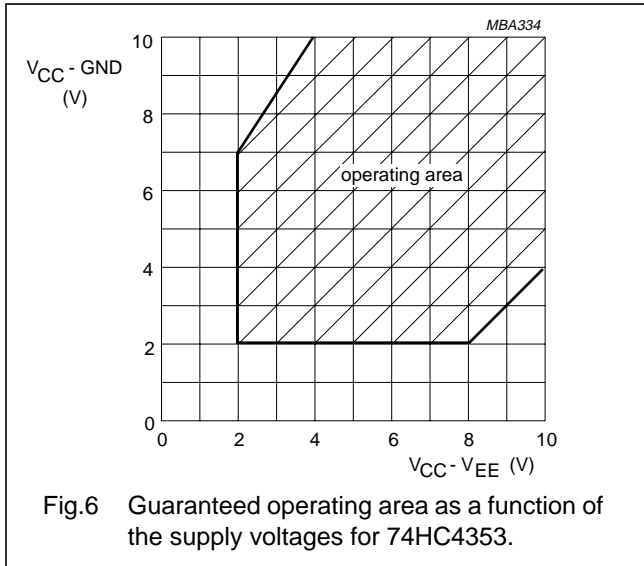

DC CHARACTERISTICS FOR 74HC/HCT

For 74HC: $V_{CC} - GND$ or $V_{CC} - V_{EE} = 2.0, 4.5, 6.0$ and 9.0 V

For 74HCT: $V_{CC} - GND = 4.5$ and 5.5 V; $V_{CC} - V_{EE} = 2.0, 4.5, 6.0$ and 9.0 V

SYMBOL	PARAMETER	T_{amb} (°C)						UNIT	TEST CONDITIONS						
		74HC/HCT								V_{CC} (V)	V_{EE} (V)	I_s (μA)	V_{is}	V_i	
		+25			-40 to +85		-40 to +125								
min.	typ.	max.	min.	max.	min.	max.									
R_{ON}	ON resistance (peak)	-	-	-	-	-	-	Ω	2.0	0	100	V_{CC} to V_{EE}	V_{IN} or V_{IL}		
		100	180	225	270	Ω	4.5	0	1000						
		90	160	200	240	Ω	6.0	0	1000						
		70	130	165	195	Ω	4.5	-4.5	1000						
R_{ON}	ON resistance (rail)	150	-	-	-	-	-	Ω	2.0	0	100	V_{EE}	V_{IH} or V_{IL}		
		80	140	175	210	Ω	4.5	0	1000						
		70	120	150	180	Ω	6.0	0	1000						
		60	105	130	160	Ω	4.5	-4.5	1000						
R_{ON}	ON resistance	150	-	-	-	-	-	Ω	2.0	0	100	V_{CC}	V_{IH} or V_{IL}		
		90	160	200	240	Ω	4.5	0	1000						
		80	140	175	210	Ω	6.0	0	1000						
		65	120	150	180	Ω	4.5	-4.5	1000						
ΔR_{ON}	maximum ΔR_{ON} resistance between any two channels	-	-	-	-	-	-	Ω	2.0	0		V_{CC} to V_{EE}	V_{IH} or V_{IL}		
		9						Ω	4.5	0					
		8						Ω	6.0	0					
		6						Ω	4.5	-4.5					

Notes to DC characteristics

- At supply voltages ($V_{CC} - V_{EE}$) approaching 2.0 V the analog switch ON-resistance becomes extremely non-linear. There it is recommended that these devices be used to transmit digital signals only, when using these supply voltages.
- For test circuit measuring R_{ON} see Fig.8.

Triple 2-channel analog multiplexer/demultiplexer with latch

74HC/HCT4353

DC CHARACTERISTICS FOR 74HC

Voltages are referenced to GND (ground = 0 V)

SYMBOL	PARAMETER	T_{amb} (°C)							UNIT	TEST CONDITIONS			
		74HC								V_{CC} (V)	V_{EE} (V)	V_I	OTHER
		+25			-40 to +85		-40 to +125						
		min.	typ.	max.	min.	max.	min.	max.					
V_{IH}	HIGH level input voltage	1.5 3.15 4.2 6.3	1.2 2.4 3.2 4.7		1.5 3.15 4.2 6.3		1.5 3.15 4.2 6.3		V	2.0 4.5 6.0 9.0			
V_{IL}	LOW level input voltage		0.8 2.1 2.8 4.3	0.5 1.35 1.8 2.7		0.5 1.35 1.8 2.7		0.5 1.35 1.8 2.7	V	2.0 4.5 6.0 9.0			
$\pm I_I$	input leakage current			0.1 0.2		1.0 2.0		1.0 2.0	μA	6.0 10.0	0	V_{CC} or GND	
$\pm I_S$	analog switch OFF-state current per channel			0.1		1.0		1.0	μA	10.0	0	V_{IH} or V_{IL}	$ V_S = V_{CC} - V_{EE}$ (see Fig.10)
$\pm I_S$	analog switch OFF-state current all channels			0.1		1.0		1.0	μA	10.0	0	V_{IH} or V_{IL}	$ V_S = V_{CC} - V_{EE}$ (see Fig.10)
$\pm I_S$	analog switch ON-state current			0.1		1.0		1.0	μA	10.0	0	V_{IH} or V_{IL}	$ V_S = V_{CC} - V_{EE}$ (see Fig.11)
I_{CC}	quiescent supply current			8.0 16.0		80.0 160.0		160.0 320.0	μA	6.0 10.0	0	V_{CC} or GND	$V_{is} = V_{EE}$ or V_{CC} ; $V_{os} = V_{CC}$ or V_{EE}

Triple 2-channel analog
multiplexer/demultiplexer with latch

74HC/HCT4353

AC CHARACTERISTICS FOR 74HC

GND = 0 V; $t_r = t_f = 6$ ns; $C_L = 50$ pF

SYMBOL	PARAMETER	T _{amb} (°C)						UNIT	TEST CONDITIONS			
		74HC							V _{CC} (V)	V _{EE} (V)	OTHER	
		+25			-40 to +85		-40 to +125					
		min.	typ.	max.	min.	max.	min.					max.
t _{PHL} / t _{PLH}	propagation delay V _{is} to V _{os}		14 5 4 4	60 12 10 8		75 15 13 10		90 18 15 12	ns	2.0 4.5 6.0 4.5	0 0 0 -4.5	R _L = ∞; C _L = 50 pF (see Fig.18)
t _{PZH} / t _{PZL}	turn "ON" time \overline{E}_1 ; E ₂ to V _{os}		61 22 18 18	250 50 43 40		315 63 54 50		375 75 64 60	ns	2.0 4.5 6.0 4.5	0 0 0 -4.5	R _L = 1 kΩ; C _L = 50 pF (see Fig.19)
t _{PZH} / t _{PZL}	turn "ON" time \overline{LE} to V _{os}		55 20 16 17	200 40 34 40		250 50 43 50		300 60 51 60	ns	2.0 4.5 6.0 4.5	0 0 0 -4.5	R _L = 1 kΩ; C _L = 50 pF (see Fig.19)
t _{PZH} / t _{PZL}	turn "ON" time S _n to V _{os}		61 22 18 17	225 45 38 40		280 56 48 50		340 68 58 60	ns	2.0 4.5 6.0 4.5	0 0 0 -4.5	R _L = 1 kΩ; C _L = 50 pF (see Fig.19)
t _{PHZ} / t _{PLZ}	turn "OFF" time \overline{E}_1 ; E ₂ to V _{os}		66 24 19 19	250 50 43 40		315 63 54 50		375 75 64 60	ns	2.0 4.5 6.0 4.5	0 0 0 -4.5	R _L = 1 kΩ; C _L = 50 pF (see Fig.19)
t _{PHZ} / t _{PLZ}	turn "OFF" time S _n to V _{os} ; \overline{LE} to V _{os}		55 20 16 19	200 40 34 40		250 50 43 50		300 60 51 60	ns	2.0 4.5 6.0 4.5	0 0 0 -4.5	R _L = 1 kΩ; C _L = 50 pF (see Fig.19)
t _{su}	set-up time S _n to \overline{LE}	60 12 10 18	17 6 5 8		75 15 13 23		90 18 15 27		ns	2.0 4.5 6.0 4.5	0 0 0 -4.5	R _L = 1 kΩ; C _L = 50 pF (see Fig.20)
t _h	hold time S _n to \overline{LE}	5 5 5 5	-6 -2 -2 -3		5 5 5 5		5 5 5 5		ns	2.0 4.5 6.0 4.5	0 0 0 -4.5	R _L = 1 kΩ; C _L = 50 pF (see Fig.20)
t _w	\overline{LE} minimum pulse width HIGH	80 16 14 16	11 4 3 6		100 20 17 20		120 24 20 24		ns	2.0 4.5 6.0 4.5	0 0 0 -4.5	R _L = 1 kΩ; C _L = 50 pF (see Fig.20)

Triple 2-channel analog multiplexer/demultiplexer with latch

74HC/HCT4353

DC CHARACTERISTICS FOR 74HCT

Voltages are referenced to GND (ground = 0 V)

SYMBOL	PARAMETER	T _{amb} (°C)							UNIT	TEST CONDITIONS			
		74HCT								V _{CC} (V)	V _{EE} (V)	V _I	OTHER
		+25			-40 to +85		-40 to +125						
		min.	typ.	max.	min.	max.	min.	max.					
V _{IH}	HIGH level input voltage	2.0	1.6		2.0		2.0		V	4.5 to 5.5			
V _{IL}	LOW level input voltage		1.2	0.8		0.8		0.8	V	4.5 to 5.5			
±I _I	input leakage current			0.1		1.0		1.0	μA	5.5	0	V _{CC} or GND	
±I _S	analog switch OFF-state current per channel			0.1		1.0		1.0	μA	10.0	0	V _{IH} or V _{IL}	V _S = V _{CC} - V _{EE} Fig.10
±I _S	analog switch OFF-state current all channels			0.1		1.0		1.0	μA	10.0	0	V _{IH} or V _{IL}	V _S = V _{CC} - V _{EE} Fig.10
±I _S	analog switch ON-state current			0.1		1.0		1.0	μA	10.0	0	V _{IH} or V _{IL}	V _S = V _{CC} - V _{EE} Fig.11
I _{CC}	quiescent supply current			8.0 16.0		80.0 160.0		160.0 320.0	μA	5.5 5.0	0 -5.0	V _{CC} or GND	V _{is} = V _{EE} or V _{CC} ; V _{os} = V _{CC} or V _{EE}
ΔI _{CC}	additional quiescent supply current per input pin for unit load coefficient is 1 (note 1)		100	360		450		490	μA	4.5 to 5.5	0	V _{CC} -2.1 V	other inputs at V _{CC} or GND

Note to HCT types

- The value of additional quiescent supply current (ΔI_{CC}) for a unit load of 1 is given here.
To determine ΔI_{CC} per input, multiply this value by the unit load coefficient shown in the table below.

INPUT	UNIT LOAD COEFFICIENT
\bar{E}_1, E_2	0.50
S_n	0.50
LE	1.5

Triple 2-channel analog multiplexer/demultiplexer with latch

74HC/HCT4353

AC CHARACTERISTICS FOR 74HCTGND = 0 V; $t_r = t_f = 6$ ns; $C_L = 50$ pF

SYMBOL	PARAMETER	T_{amb} (°C)						UNIT	TEST CONDITIONS			
		74HCT							V_{CC} (V)	V_{EE} (V)	OTHER	
		+25			-40 to +85		-40 to +125					
		min.	typ.	max.	min.	max.	min.					max.
t_{PHL}/t_{PLH}	propagation delay V_{is} to V_{os}		5 4	12 8		15 10		18 12	ns	4.5 4.5	0 -4.5	$R_L = \infty$; $C_L = 50$ pF (see Fig.18)
t_{PZH}/t_{PZL}	turn "ON" time \overline{E}_1 to V_{os}		26 22	55 45		69 56		83 68	ns	4.5 4.5	0 -4.5	$R_L = 1$ k Ω ; $C_L = 50$ pF (see Fig.19)
t_{PZH}/t_{PZL}	turn "ON" time E_2 to V_{os}		22 18	50 40		63 50		75 60	ns	4.5 4.5	0 -4.5	$R_L = 1$ k Ω ; $C_L = 50$ pF (see Fig.19)
t_{PZH}/t_{PZL}	turn "ON" time \overline{LE} to V_{os}		21 17	45 40		56 50		68 60	ns	4.5 4.5	0 -4.5	$R_L = 1$ k Ω ; $C_L = 50$ pF (see Fig.19)
t_{PZH}/t_{PZL}	turn "ON" time S_n to V_{os}		25 19	50 45		63 56		75 68	ns	4.5 4.5	0 -4.5	$R_L = 1$ k Ω ; $C_L = 50$ pF (see Fig.19)
t_{PHZ}/t_{PLZ}	turn "OFF" time \overline{E}_1 to V_{os}		23 19	50 40		63 50		75 60	ns	4.5 4.5	0 -4.5	$R_L = 1$ k Ω ; $C_L = 50$ pF (see Fig.19)
t_{PHZ}/t_{PLZ}	turn "OFF" time E_2 to V_{os}		27 23	50 40		63 50		75 60	ns	4.5 4.5	0 -4.5	$R_L = 1$ k Ω ; $C_L = 50$ pF (see Fig.19)
t_{PHZ}/t_{PLZ}	turn "OFF" time \overline{LE} to V_{os}		19 19	40 40		50 50		60 60	ns	4.5 4.5	0 -4.5	$R_L = 1$ k Ω ; $C_L = 50$ pF (see Fig.19)
t_{PHZ}/t_{PLZ}	turn "OFF" time S_n to V_{os}		22 22	45 45		56 56		68 68	ns	4.5 4.5	0 -4.5	$R_L = 1$ k Ω ; $C_L = 50$ pF (see Fig.19)
t_{su}	set-up time S_n to \overline{LE}	12 15	7 9		15 19		18 22		ns	4.5 4.5	0 -4.5	$R_L = 1$ k Ω ; $C_L = 50$ pF (see Fig.20)
t_h	hold time S_n to \overline{LE}	5 5	0 -2		5 5		5 5		ns	4.5 4.5	0 -4.5	$R_L = 1$ k Ω ; $C_L = 50$ pF (see Fig.20)
t_w	\overline{LE} minimum pulse width HIGH	16 16	3 5		20 20		24 24		ns	4.5 4.5	0 -4.5	$R_L = 1$ k Ω ; $C_L = 50$ pF (see Fig.20)

Triple 2-channel analog multiplexer/demultiplexer with latch

74HC/HCT4353

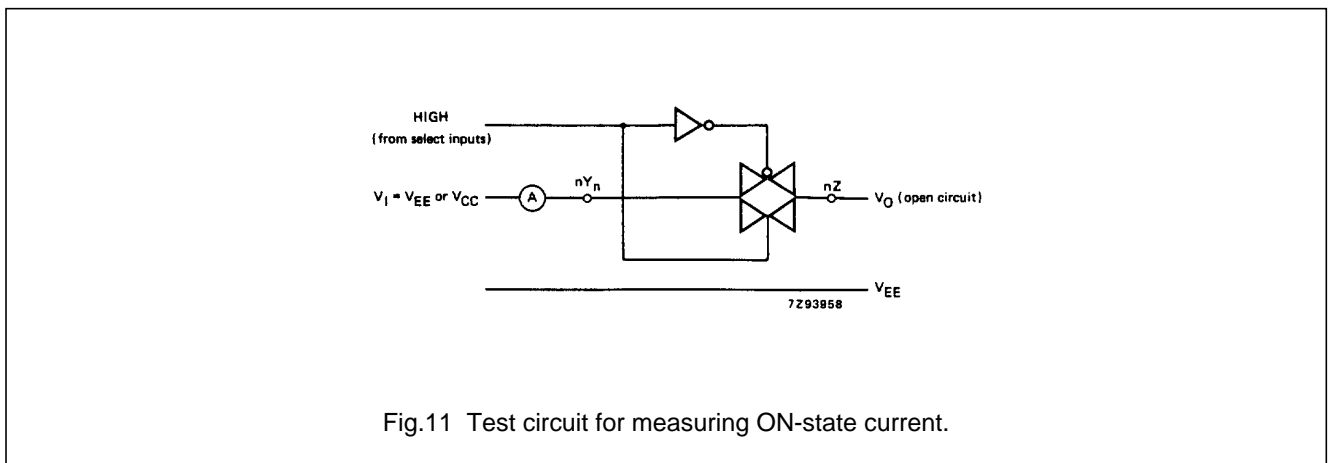
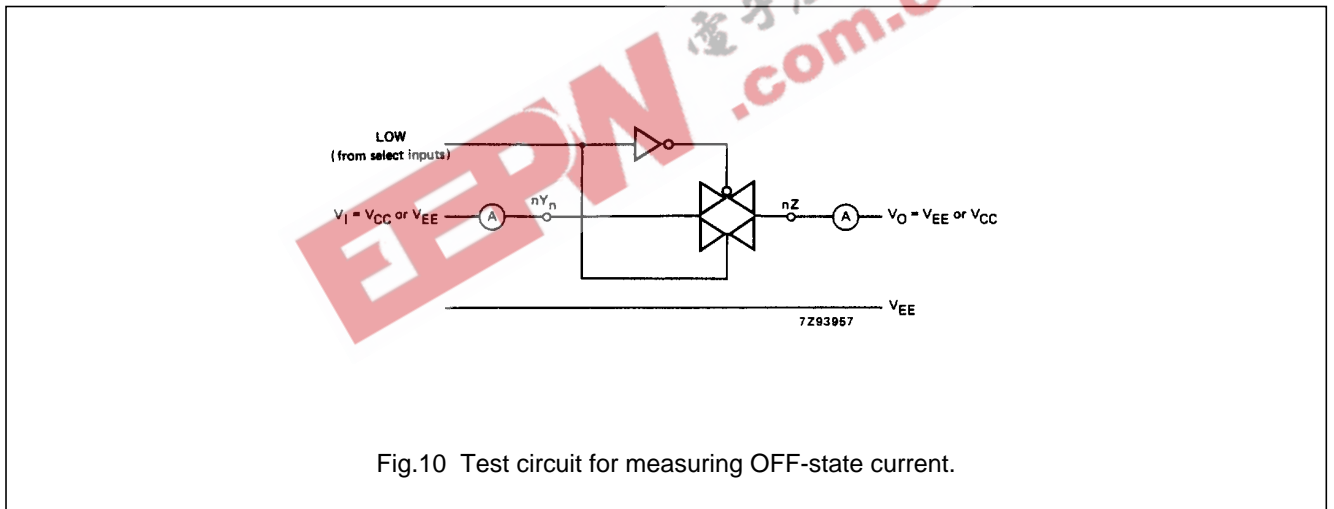
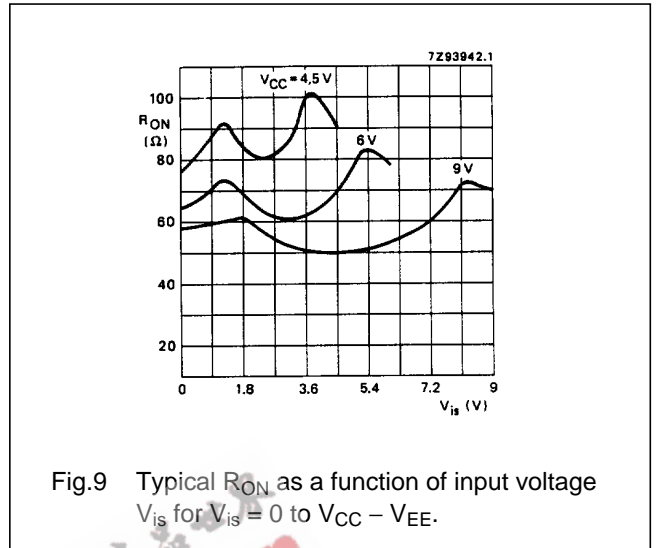
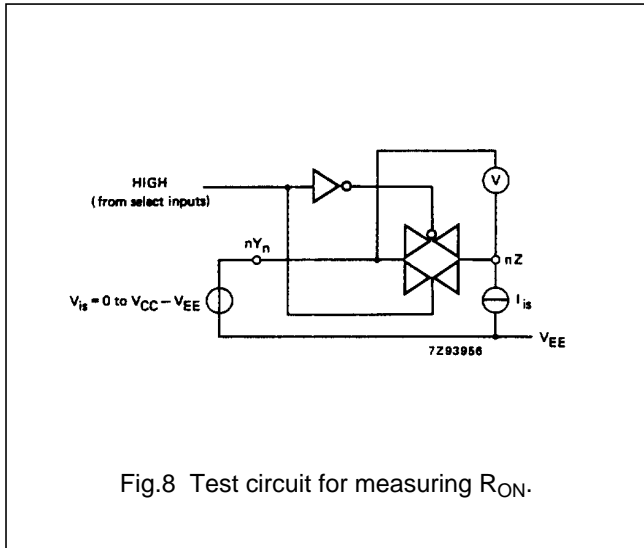

Triple 2-channel analog
multiplexer/demultiplexer with latch

74HC/HCT4353

ADDITIONAL AC CHARACTERISTICS FOR 74HC/HCT

Recommended conditions and typical values

GND = 0 V; T_{amb} = 25 °C

SYMBOL	PARAMETER	typ.	UNIT	V _{CC} (V)	V _{EE} (V)	V _{is(p-p)} (V)	CONDITIONS
	sine-wave distortion f = 1 kHz	0.04 0.02	% %	2.25 4.5	-2.25 -4.5	4.0 8.0	R _L = 10 kΩ; C _L = 50 pF (see Fig.14)
	sine-wave distortion f = 10 kHz	0.12 0.06	% %	2.25 4.5	-2.25 -4.5	4.0 8.0	R _L = 10 kΩ; C _L = 50 pF (see Fig.14)
	switch "OFF" signal feed-through	-50 -50	dB dB	2.25 4.5	-2.25 -4.5	note 1	R _L = 600 Ω; C _L = 50 pF f = 1 MHz (see Figs 12 and 15)
	crosstalk between any two switches/ multiplexers	-60 -60	dB dB	2.25 4.5	-2.25 -4.5	note 1	R _L = 600 Ω; C _L = 50 pF; f = 1 MHz (see Fig.16)
V _(p-p)	crosstalk voltage between control and any switch (peak-to-peak value)	110 220	mV mV	4.5 4.5	0 -4.5		R _L = 600 Ω; C _L = 50 pF; f = 1 MHz (\bar{E}_1 , E ₂ or S _n , square-wave between V _{CC} and GND, t _r = t _f = 6 ns) (see Fig.17)
f _{max}	minimum frequency response (-3dB)	160 170	MHz MHz	2.25 4.5	-2.25 -4.5	note 2	R _L = 50 Ω; C _L = 10 pF (see Figs 13 and 14)
C _S	maximum switch capacitance independent (Y) common (Z)	5 12	pF pF				

Notes to the AC characteristics

1. Adjust input voltage V_{is} to 0 dBm level (0 dBm = 1 mW into 600 Ω).
2. Adjust input voltage V_{is} to 0 dBm level at V_{os} for 1 MHz (0 dBm = 1 mW into 50 Ω).

General note

V_{is} is the input voltage at an nY_n or nZ terminal, whichever is assigned as an input.

V_{os} is the output voltage at an nY_n or nZ terminal, whichever is assigned as an output.

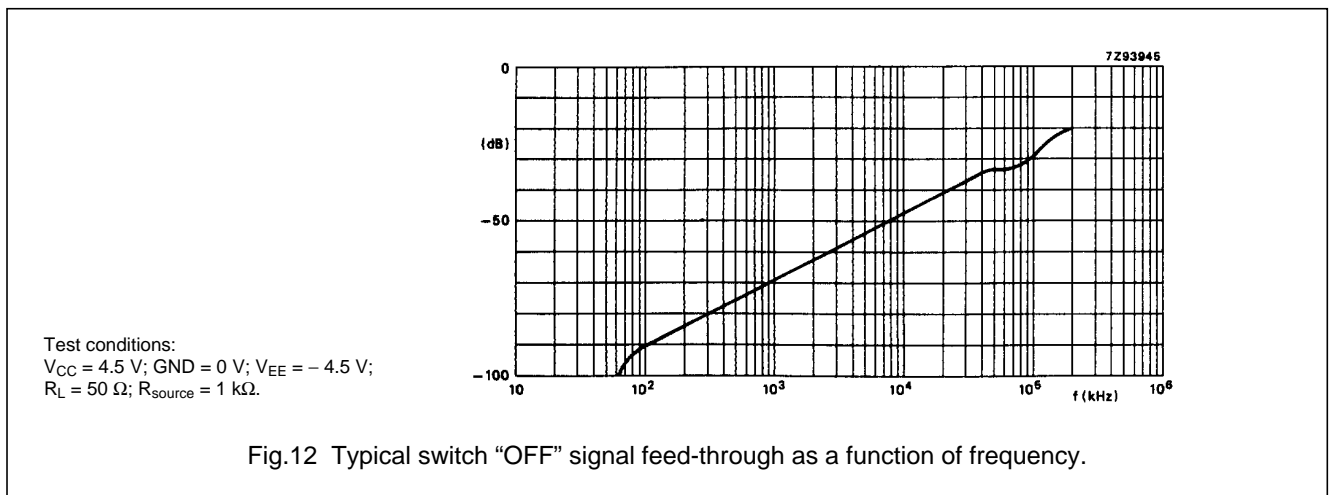

Triple 2-channel analog multiplexer/demultiplexer with latch

74HC/HCT4353

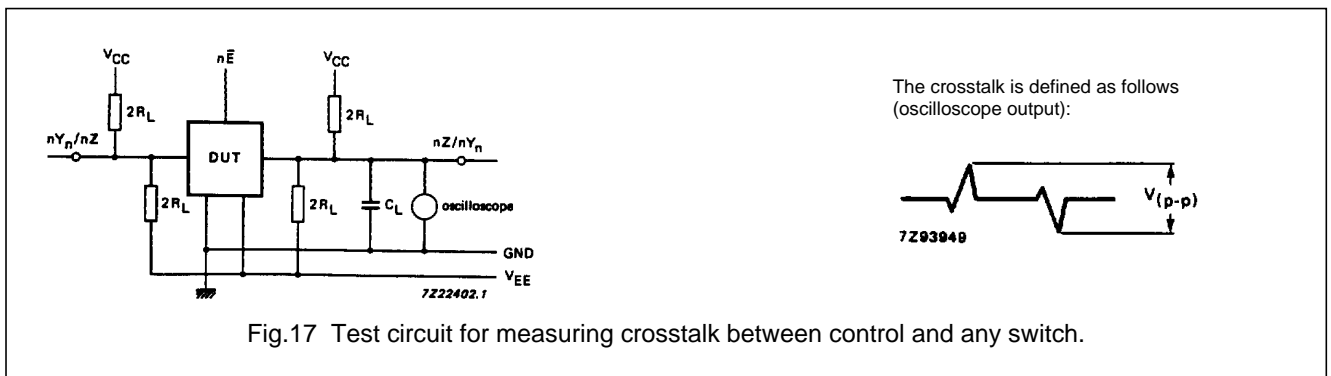
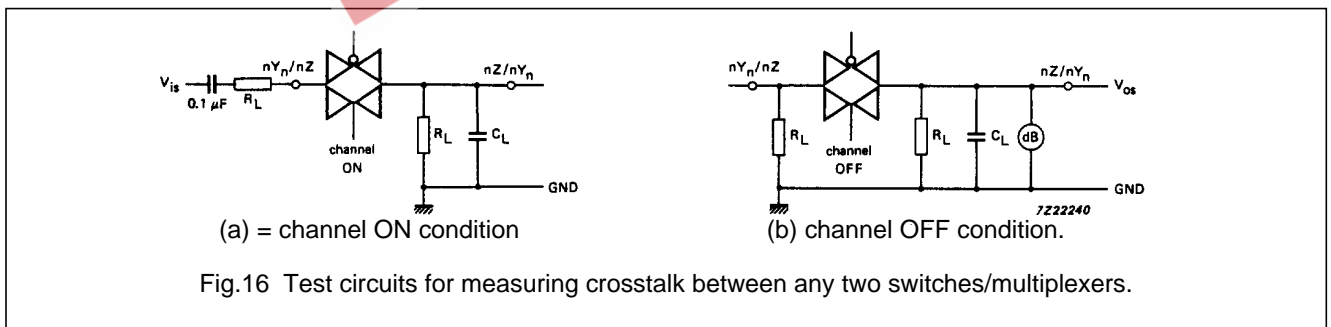
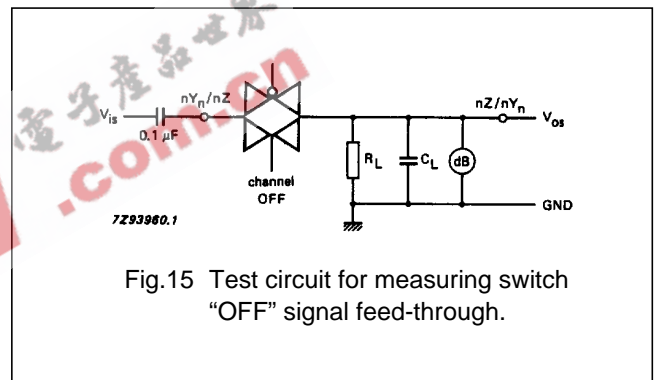
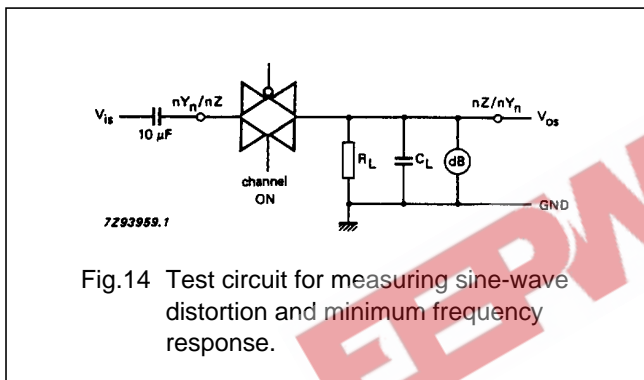
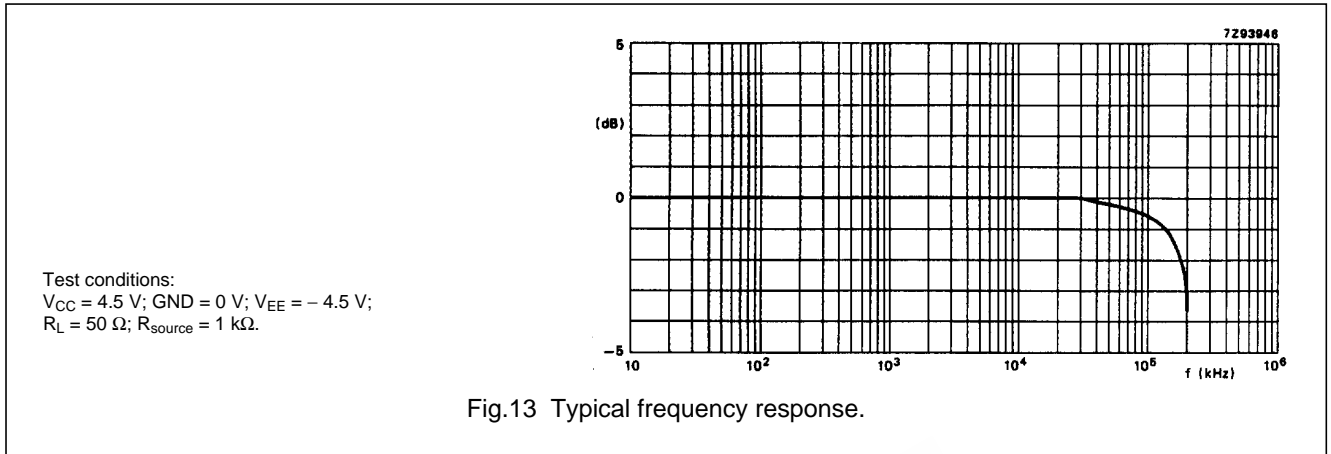

Triple 2-channel analog multiplexer/demultiplexer with latch

74HC/HCT4353

AC WAVEFORMS

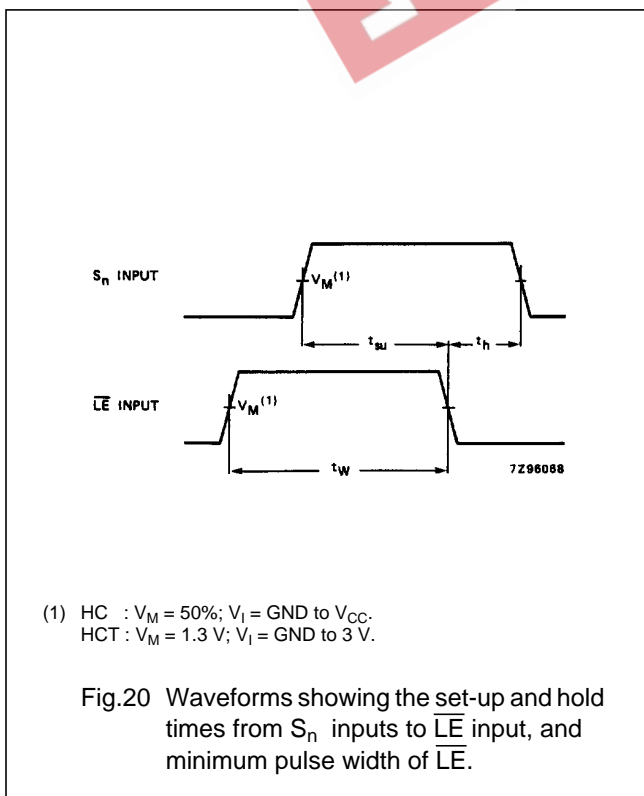
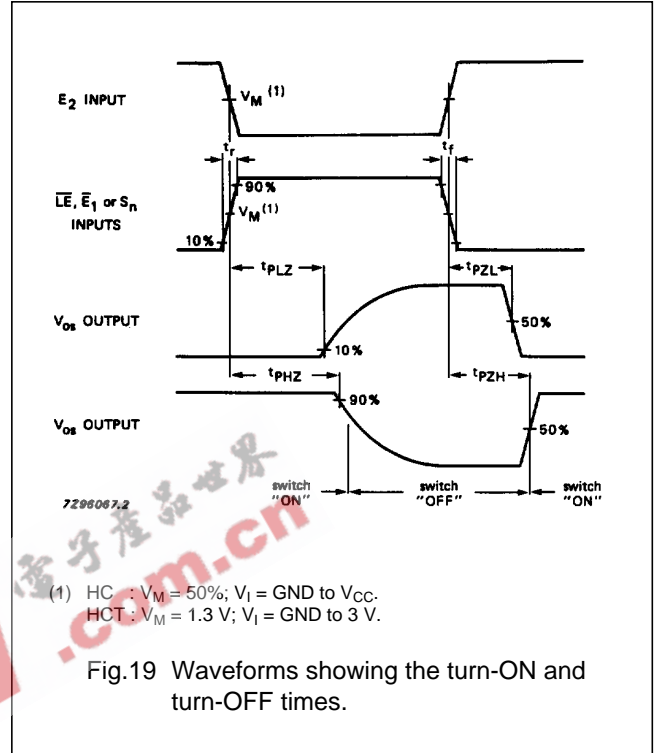
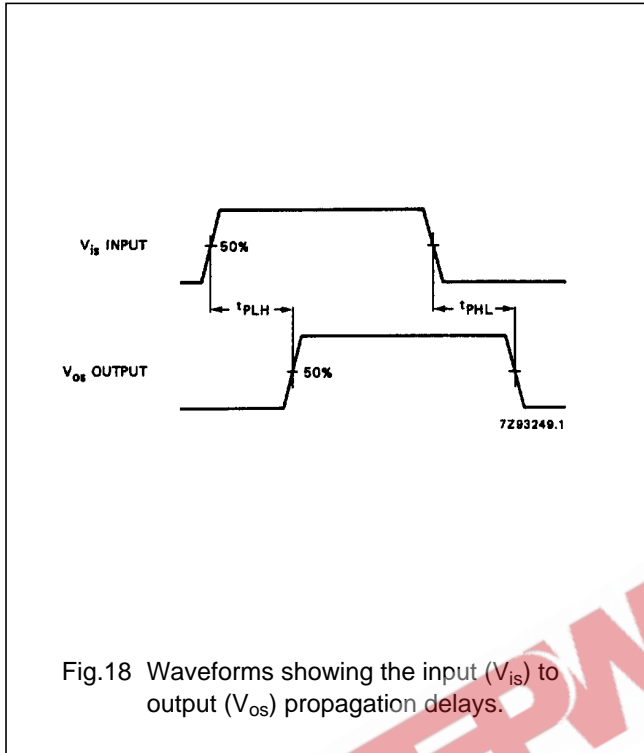

(1) HC : $V_M = 50\%$; $V_I = \text{GND to } V_{CC}$.
 HCT : $V_M = 1.3 \text{ V}$; $V_I = \text{GND to } 3 \text{ V}$.

Triple 2-channel analog multiplexer/demultiplexer with latch

74HC/HCT4353

TEST CIRCUIT AND WAVEFORMS

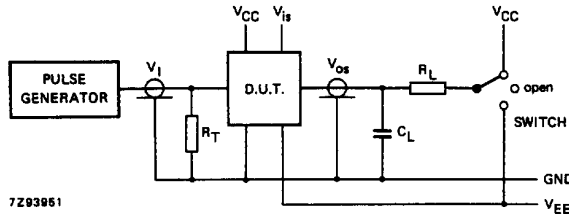

Conditions

TEST	SWITCH	V _{is}
t _{PZH}	V _{EE}	V _{CC}
t _{PZL}	V _{CC}	V _{EE}
t _{PHZ}	V _{EE}	V _{CC}
t _{PLZ}	V _{CC}	V _{EE}
others	open	pulse

FAMILY	AMPLITUDE	V _M	t _r ; t _f	
			f _{max} ; PULSE WIDTH	OTHER
74HC	V _{CC}	50%	< 2 ns	6 ns
74HCT	3.0 V	1.3 V	< 2 ns	6 ns

- C_L = load capacitance including jig and probe capacitance (see AC CHARACTERISTICS for values).
- R_T = termination resistance should be equal to the output impedance Z_O of the pulse generator.
- t_r = t_f = 6 ns; when measuring f_{max}, there is no constraint on t_r, t_f with 50% duty factor.

Fig.21 Test circuit for measuring AC performance.

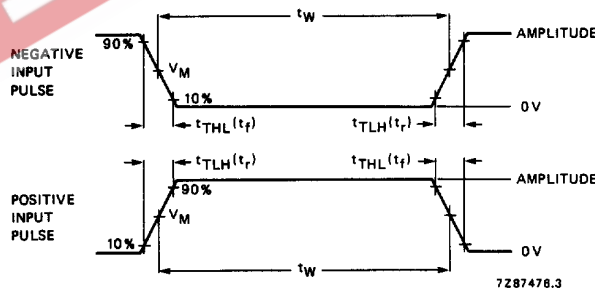

Conditions

TEST	SWITCH	V _{is}
t _{PZH}	V _{EE}	V _{CC}
t _{PZL}	V _{CC}	V _{EE}
t _{PHZ}	V _{EE}	V _{CC}
t _{PLZ}	V _{CC}	V _{EE}
others	open	pulse

FAMILY	AMPLITUDE	V _M	t _r ; t _f	
			f _{max} ; PULSE WIDTH	OTHER
74HC	V _{CC}	50%	< 2 ns	6 ns
74HCT	3.0 V	1.3 V	< 2 ns	6 ns

- C_L = load capacitance including jig and probe capacitance (see AC CHARACTERISTICS for values).
- R_T = termination resistance should be equal to the output impedance Z_O of the pulse generator.
- t_r = t_f = 6 ns; when measuring f_{max}, there is no constraint on t_r, t_f with 50% duty factor.

Fig.22 Input pulse definitions.

Triple 2-channel analog
multiplexer/demultiplexer with latch

74HC/HCT4353

PACKAGE OUTLINES

See *"74HC/HCT/HCU/HCMOS Logic Package Outlines"*.

