

DATA SHEET

EEPW 电子產品世界
.com.cn

74LVC139

Dual 2-to-4 line decoder/demultiplexer

Product specification
Supersedes data of 1997 Jun 19
IC24 Data Handbook

1998 Apr 28

Dual 2-to-4 line decoder/demultiplexer

74LVC139

FEATURES

- Wide supply voltage range of 1.2 to 3.6 V
- In accordance with JEDEC standard no. 8-1A
- Inputs accept voltages up to 5.5 V
- CMOS lower power consumption
- Direct interface with TTL levels
- Demultiplexing capability
- Two independent 2-to-4 decoders
- Multifunction capability
- Active LOW mutually exclusive outputs
- Output drive capability 50 Ω transmission lines at 85°C

DESCRIPTION

The 74LVC139 is a low-voltage, low-power, high-performance Si-gate CMOS device, superior to most advanced CMOS compatible TTL families.

The 74LVC139 is a dual 2-to-4 line decoder/demultiplexer. This device has two independent decoders, each accepting two binary weighted inputs (nA_0 and nA_1) and providing four mutually exclusive active LOW outputs ($n\bar{Y}_0$ to $n\bar{Y}_3$). Each decoder has an active LOW input ($n\bar{E}$).

When $n\bar{E}$ is HIGH, every output is forced HIGH. The enable can be used as the data input for a 1-to-4 demultiplexer application.

QUICK REFERENCE DATA

GND = 0 V; $T_{amb} = 25^\circ\text{C}$; $t_r = t_f \leq 2.5$ ns

SYMBOL	PARAMETER	CONDITIONS	TYPICAL	UNIT
t_{PHL}/t_{PLH}	Propagation delay nA to $n\bar{Y}_n$, $n\bar{E}$ to $n\bar{Y}_n$	$C_L = 50$ pF; $V_{CC} = 3.3$ V	3.3 3.2	ns
C_I	Input capacitance		5.0	pF
C_{PD}	Power dissipation capacitance per multiplexer	$V_{CC} = 3.3$ V Notes 1 and 2	36	pF

NOTES:

- C_{PD} is used to determine the dynamic power dissipation (P_D in μW)
 $P_D = C_{PD} \times V_{CC}^2 \times f_i + \sum (C_L \times V_{CC}^2 \times f_o)$ where:
 f_i = input frequency in MHz; C_L = output load capacity in pF;
 f_o = output frequency in MHz; V_{CC} = supply voltage in V;
 $\sum (C_L \times V_{CC}^2 \times f_o)$ = sum of the outputs.
- The condition is $V_1 = \text{GND}$ to V_{CC}

ORDERING INFORMATION

PACKAGES	TEMPERATURE RANGE	OUTSIDE NORTH AMERICA	NORTH AMERICA	PKG. DWG. #
16-Pin Plastic SO	-40°C to +85°C	74LVC139 D	74LVC139 D	SOT109-1
16-Pin Plastic SSOP Type II	-40°C to +85°C	74LVC139 DB	74LVC139 DB	SOT338-1
16-Pin Plastic TSSOP Type I	-40°C to +85°C	74LVC139 PW	74LVC139PW DH	SOT403-1

PIN CONFIGURATION

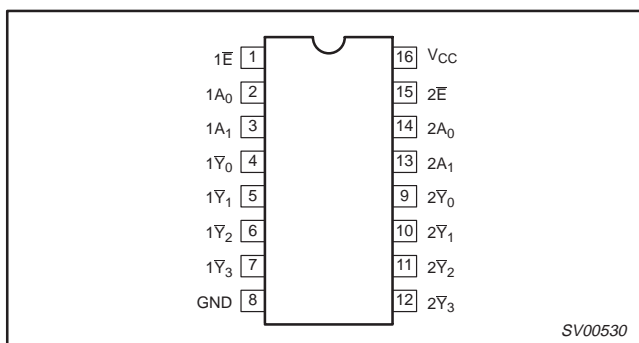

PIN DESCRIPTION

PIN NUMBER	SYMBOL	NAME AND FUNCTION
1, 15	$1\bar{E}$, $2\bar{E}$	Enable inputs (active LOW)
2, 3	$1A_0$, $1A_1$	Address inputs
14, 13	$2A_0$, $2A_1$	
4, 5, 6, 7	$1\bar{Y}_0$ to $1\bar{Y}_3$	Outputs (active LOW)
12, 11, 10, 9	$2\bar{Y}_0$ to $2\bar{Y}_3$	
8	GND	Ground (0 V)
16	V_{CC}	Positive supply voltage

Dual 2-to-4 line decoder/demultiplexer

74LVC139

LOGIC DIAGRAM

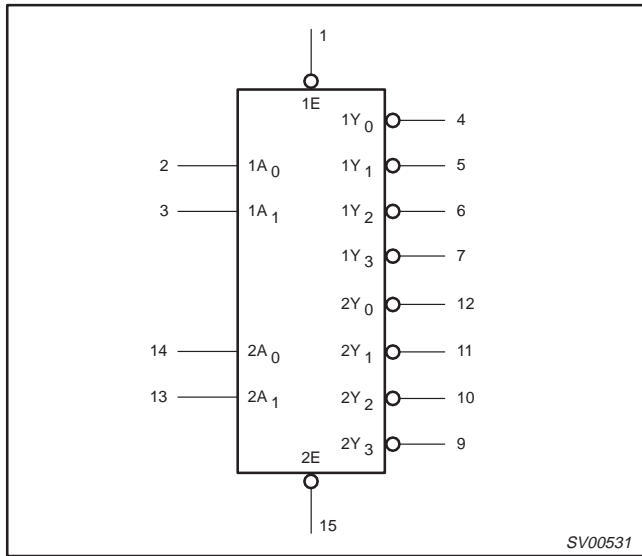

FUNCTIONAL DIAGRAM

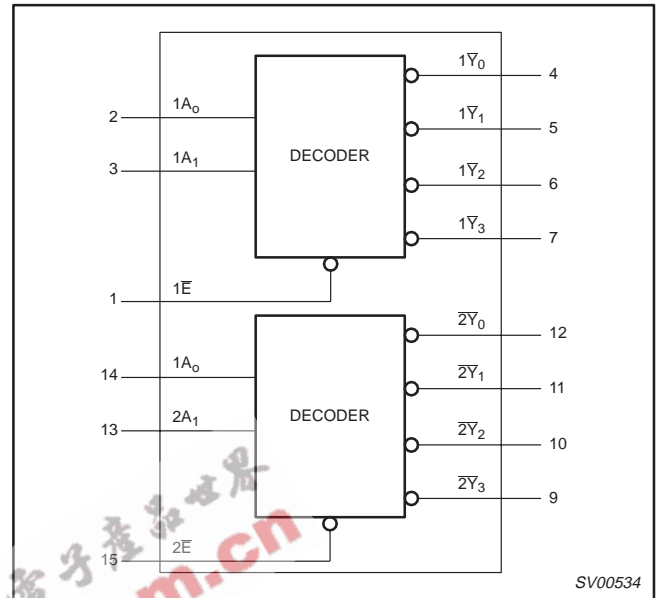

LOGIC SYMBOL (IEEE/IEC)

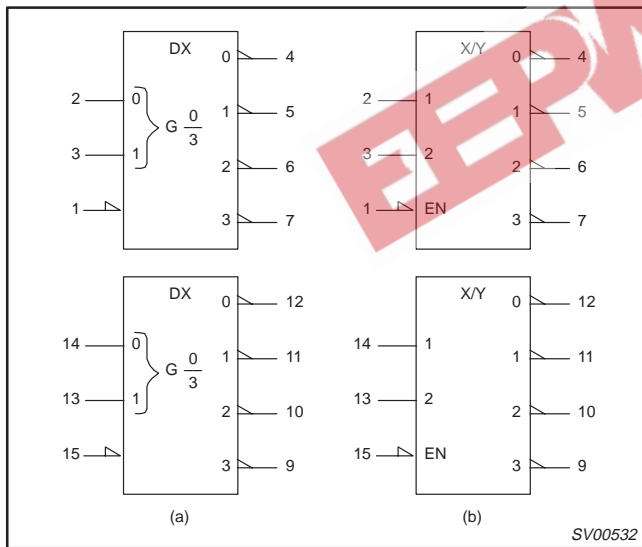

FUNCTION TABLE

INPUTS			OUTPUTS			
nE	nA ₀	nA ₁	nY ₀	nY ₁	nY ₂	nY ₃
H	X	X	H	H	H	H
L	L	L	L	H	H	H
L	H	L	H	L	H	H
L	L	H	H	H	L	H
L	H	H	H	H	H	L

NOTES:

- H = HIGH voltage level
- L = LOW voltage level
- X = don't care

Dual 2-to-4 line decoder/demultiplexer

74LVC139

RECOMMENDED OPERATING CONDITIONS

SYMBOL	PARAMETER	CONDITIONS	LIMITS		UNIT
			MIN	MAX	
V _{CC}	DC supply voltage (for max. speed performance)		2.7	3.6	V
	DC supply voltage (for low-voltage applications)		1.2	3.6	
V _I	DC input voltage range		0	5.5	V
V _O	DC output voltage range		0	V _{CC}	V
T _{amb}	Operating free-air temperature range in free air		-40	+85	°C
t _r , t _f	Input rise and fall times	V _{CC} = 1.2 to 2.7V V _{CC} = 2.7 to 3.6V	0 0	20 10	ns/V

ABSOLUTE MAXIMUM RATINGS¹

In accordance with the Absolute Maximum Rating System (IEC 134).
Voltages are referenced to GND (ground = 0V).

SYMBOL	PARAMETER	CONDITIONS	RATING	UNIT
V _{CC}	DC supply voltage		-0.5 to +6.5	V
I _{IK}	DC input diode current	V _I < 0	-50	mA
V _I	DC input voltage	Note 2	-0.5 to +5.5	V
I _{OK}	DC output diode current	V _O > V _{CC} or V _O < 0	±50	mA
V _O	DC output voltage	Note 2	-0.5 to V _{CC} +0.5	V
I _O	DC output source or sink current	V _O = 0 to V _{CC}	±50	mA
I _{GND} , I _{CC}	DC V _{CC} or GND current		±100	mA
T _{stg}	Storage temperature range		-65 to +150	°C
P _{TOT}	Power dissipation per package			
	- plastic mini-pack (SO) - plastic shrink mini-pack (SSOP and TSSOP)	above +70°C derate linearly with 8 mW/K above +60°C derate linearly with 5.5 mW/K	500 500	mW

NOTES:

- Stresses beyond those listed may cause permanent damage to the device. These are stress ratings only and functional operation of the device at these or any other conditions beyond those indicated under "recommended operating conditions" is not implied. Exposure to absolute-maximum-rated conditions for extended periods may affect device reliability.
- The input and output voltage ratings may be exceeded if the input and output current ratings are observed.

Dual 2-to-4 line decoder/demultiplexer

74LVC139

DC ELECTRICAL CHARACTERISTICS

Over recommended operating conditions. Voltages are referenced to GND (ground = 0V)

SYMBOL	PARAMETER	TEST CONDITIONS	LIMITS			UNIT
			Temp = -40°C to +85°C			
			MIN	TYP ¹	MAX	
V _{IH}	HIGH level input voltage	V _{CC} = 1.2V	V _{CC}			V
		V _{CC} = 2.7 to 3.6V	2.0			
V _{IL}	LOW level input voltage	V _{CC} = 1.2V			GND	V
		V _{CC} = 2.7 to 3.6V			0.8	
V _{OH}	HIGH level output voltage	V _{CC} = 2.7V; V _I = V _{IH} or V _{IL} ; I _O = -12mA	V _{CC} - 0.5			V
		V _{CC} = 3.0V; V _I = V _{IH} or V _{IL} ; I _O = -100µA	V _{CC} - 0.2	V _{CC}		
		V _{CC} = 3.0V; V _I = V _{IH} or V _{IL} ; I _O = -12mA	V _{CC} - 0.6			
		V _{CC} = 3.0V; V _I = V _{IH} or V _{IL} ; I _O = -24mA	V _{CC} - 0.8			
V _{OL}	LOW level output voltage	V _{CC} = 2.7V; V _I = V _{IH} or V _{IL} ; I _O = 12mA			0.40	V
		V _{CC} = 3.0V; V _I = V _{IH} or V _{IL} ; I _O = 100µA			0.20	
		V _{CC} = 3.0V; V _I = V _{IH} or V _{IL} ; I _O = 24mA			0.55	
I _I	Input leakage current	V _{CC} = 3.6V; V _I = 5.5V or GND		±0.1	±5	µA
I _{CC}	Quiescent supply current	V _{CC} = 3.6V; V _I = V _{CC} or GND; I _O = 0		0.1	10	µA
ΔI _{CC}	Additional quiescent supply current per input pin	V _{CC} = 2.7V to 3.6V; V _I = V _{CC} - 0.6V; I _O = 0		5	500	µA

NOTE:1. All typical values are at V_{CC} = 3.3V and T_{amb} = 25°C.**AC CHARACTERISTICS**GND = 0 V; t_r = t_f ≤ 2.5 ns; C_L = 50 pF; R_L = 500Ω; T_{amb} = -40°C to +85°C

SYMBOL	PARAMETER	WAVEFORM	LIMITS					UNIT
			V _{CC} = 3.3V ±0.3V			V _{CC} = 2.7V		
			MIN	TYP ¹	MAX	MIN	MAX	
t _{PHL} /t _{PLH}	Propagation delay nA _n to \bar{Y}_n	1, 3	1.5	3.3	6.0		7.5	ns
t _{PHL} /t _{PLH}	Propagation delay nE to \bar{Y}_n	2, 3	1.5	3.2	5.5		6.5	ns

NOTE:1. These typical values are at V_{CC} = 3.3V and T_{amb} = 25°C.

Dual 2-to-4 line decoder/demultiplexer

74LVC139

AC WAVEFORMS

$V_M = 1.5\text{ V}$ at $V_{CC} \geq 2.7\text{ V}$

$V_M = 0.5 \times V_{CC}$ at $V_{CC} < 2.7\text{ V}$

V_{OL} and V_{OH} are the typical output voltage drop that occur with the output load.

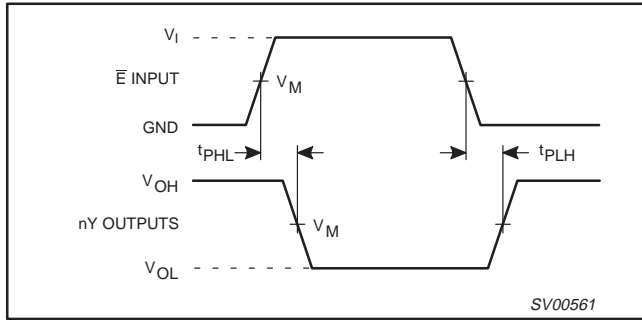

Figure 1. Input (nA) to output (nY) propagation delays.

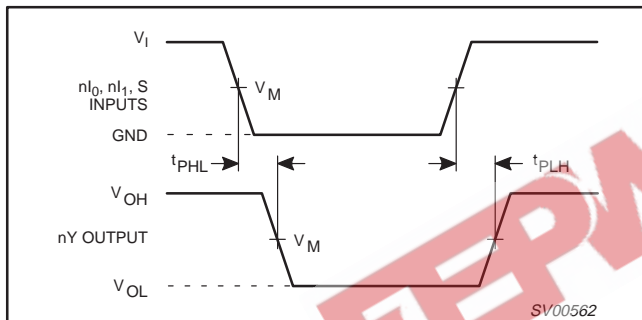

Figure 2. Enable input (nE) to output (nYn) propagation delays.

TEST CIRCUIT

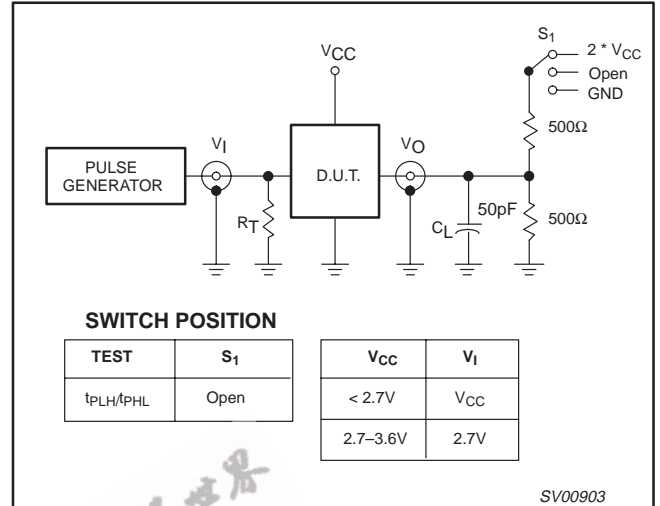

Figure 3. Load circuitry for switching times.

Dual 2-to-4 line decoder/demultiplexer

74LVC139

SO16: plastic small outline package; 16 leads; body width 3.9 mm

SOT109-1

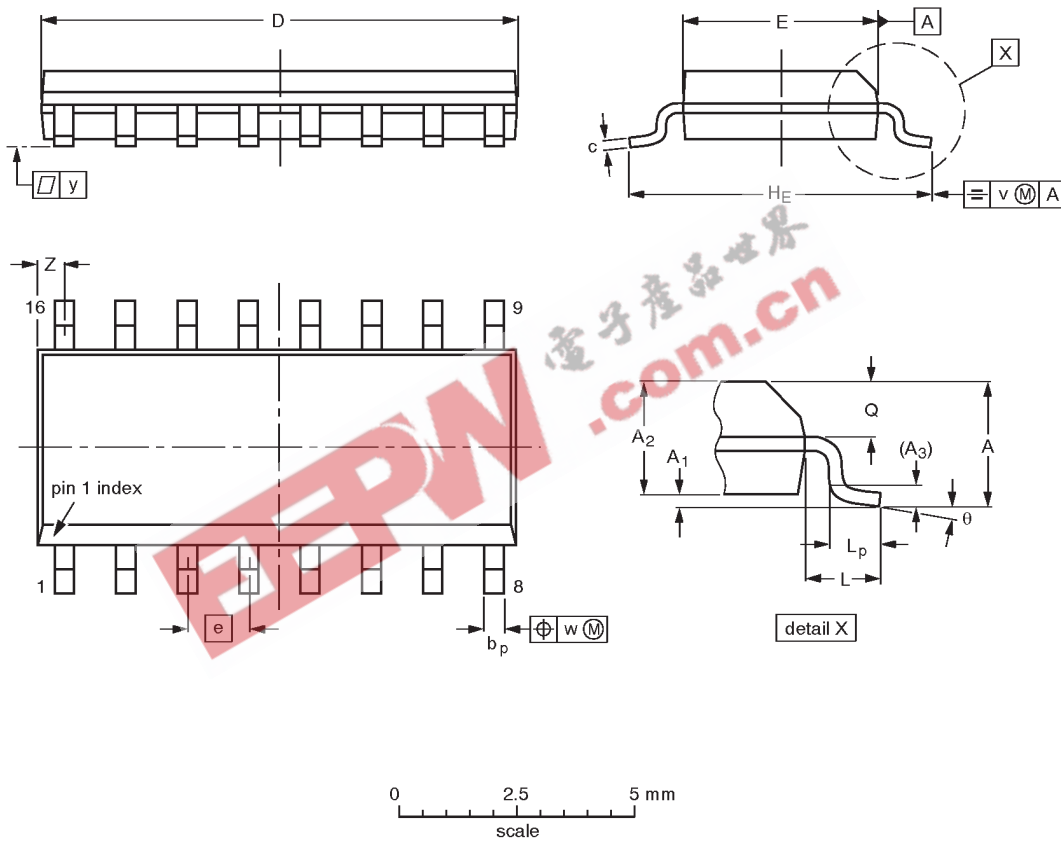

DIMENSIONS (inch dimensions are derived from the original mm dimensions)

UNIT	A max.	A ₁	A ₂	A ₃	b _p	c	D ⁽¹⁾	E ⁽¹⁾	e	H _E	L	L _p	Q	v	w	y	Z ⁽¹⁾	θ
mm	1.75	0.25 0.10	1.45 1.25	0.25	0.49 0.36	0.25 0.19	10.0 9.8	4.0 3.8	1.27	6.2 5.8	1.05	1.0 0.4	0.7 0.6	0.25	0.25	0.1	0.7 0.3	8° 0°
inches	0.069	0.0098 0.0039	0.057 0.049	0.01	0.019 0.014	0.0098 0.0075	0.39 0.38	0.16 0.15	0.050	0.24 0.23	0.041	0.039 0.016	0.028 0.020	0.01	0.01	0.004	0.028 0.012	

Note

1. Plastic or metal protrusions of 0.15 mm maximum per side are not included.

OUTLINE VERSION	REFERENCES				EUROPEAN PROJECTION	ISSUE DATE
	IEC	JEDEC	EIAJ			
SOT109-1	076E07S	MS-012AC				91-08-13 95-01-23

Dual 2-to-4 line decoder/demultiplexer

74LVC139

SSOP16: plastic shrink small outline package; 16 leads; body width 5.3 mm

SOT338-1

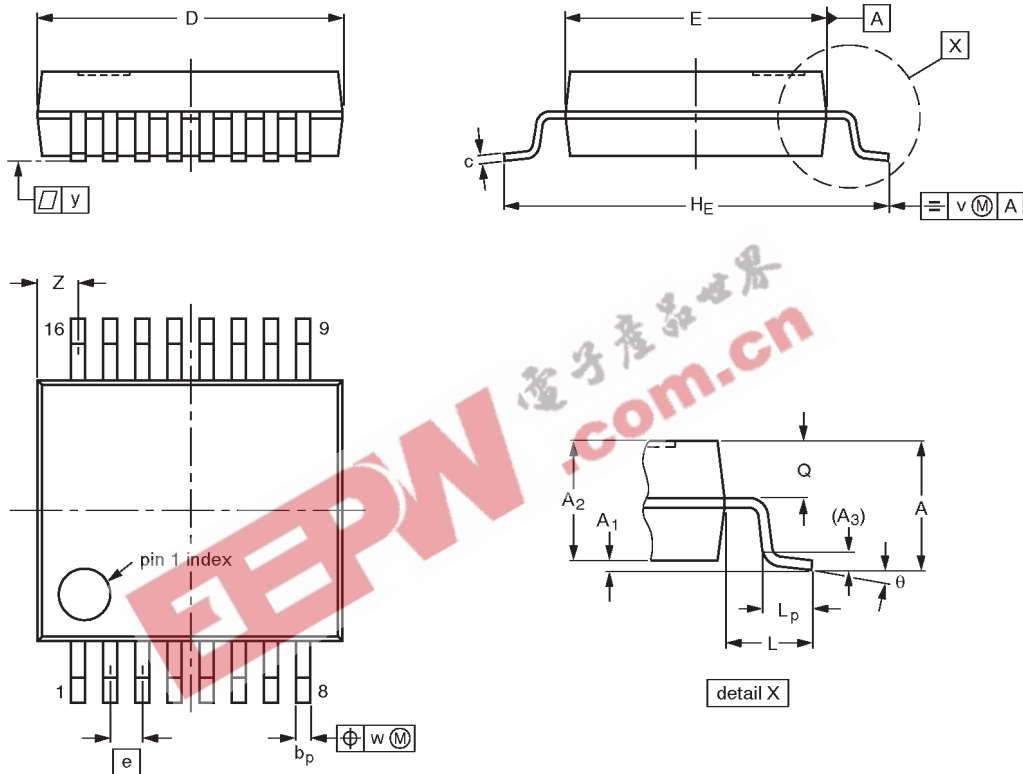

DIMENSIONS (mm are the original dimensions)

UNIT	A max.	A ₁	A ₂	A ₃	b _p	c	D ⁽¹⁾	E ⁽¹⁾	e	H _E	L	L _p	Q	v	w	y	z ⁽¹⁾	θ
mm	2.0	0.21 0.05	1.80 1.65	0.25	0.38 0.25	0.20 0.09	6.4 6.0	5.4 5.2	0.65	7.9 7.6	1.25	1.03 0.63	0.9 0.7	0.2	0.13	0.1	1.00 0.55	8° 0°

Note

1. Plastic or metal protrusions of 0.25 mm maximum per side are not included.

OUTLINE VERSION	REFERENCES				EUROPEAN PROJECTION	ISSUE DATE
	IEC	JEDEC	EIAJ			
SOT338-1		MO-150AC				94-01-14 95-02-04

Dual 2-to-4 line decoder/demultiplexer

74LVC139

TSSOP16: plastic thin shrink small outline package; 16 leads; body width 4.4 mm

SOT403-1

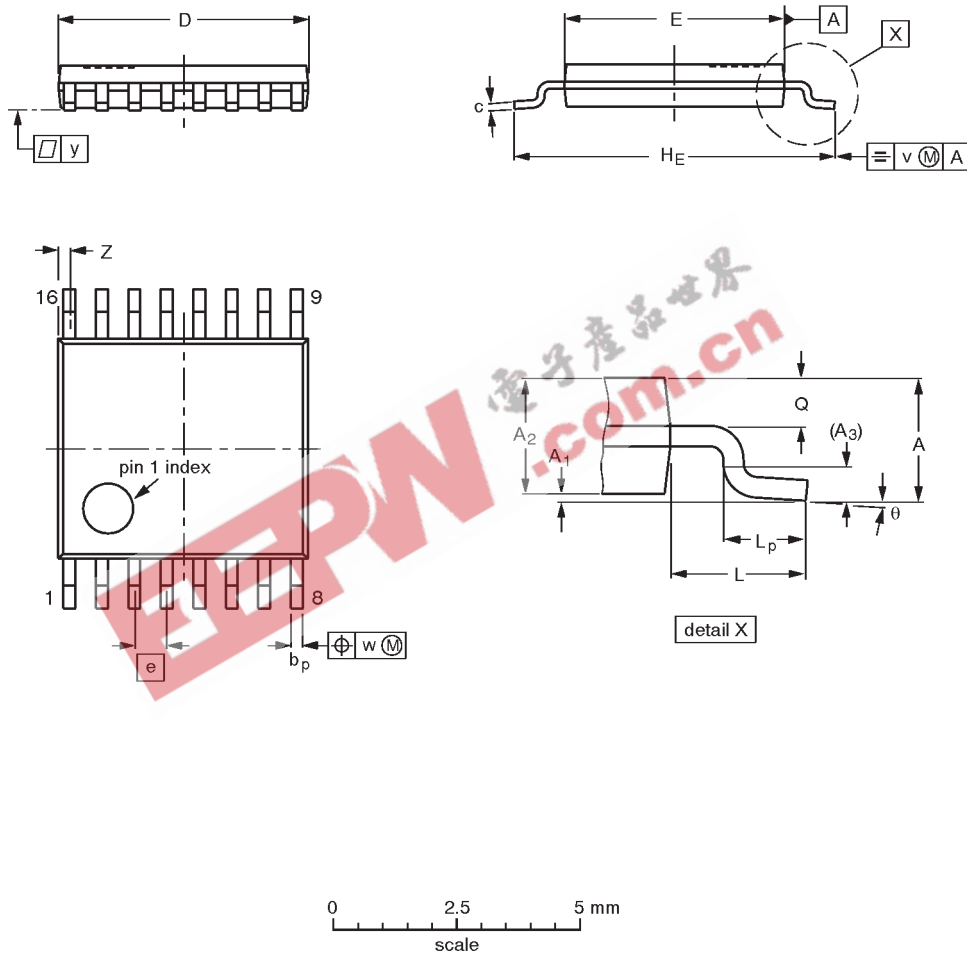

DIMENSIONS (mm are the original dimensions)

UNIT	A max.	A ₁	A ₂	A ₃	b _p	c	D ⁽¹⁾	E ⁽²⁾	e	H _E	L	L _p	Q	v	w	y	Z ⁽¹⁾	θ
mm	1.10	0.15 0.05	0.95 0.80	0.25	0.30 0.19	0.2 0.1	5.1 4.9	4.5 4.3	0.65	6.6 6.2	1.0	0.75 0.50	0.4 0.3	0.2	0.13	0.1	0.40 0.06	8° 0°

Notes

1. Plastic or metal protrusions of 0.15 mm maximum per side are not included.
2. Plastic interlead protrusions of 0.25 mm maximum per side are not included.

OUTLINE VERSION	REFERENCES				EUROPEAN PROJECTION	ISSUE DATE
	IEC	JEDEC	EIAJ			
SOT403-1		MO-153				94-07-12 95-04-04

Dual 2-to-4 line decoder/demultiplexer

74LVC139

DEFINITIONS

Data Sheet Identification	Product Status	Definition
<i>Objective Specification</i>	Formative or in Design	This data sheet contains the design target or goal specifications for product development. Specifications may change in any manner without notice.
<i>Preliminary Specification</i>	Preproduction Product	This data sheet contains preliminary data, and supplementary data will be published at a later date. Philips Semiconductors reserves the right to make changes at any time without notice in order to improve design and supply the best possible product.
<i>Product Specification</i>	Full Production	This data sheet contains Final Specifications. Philips Semiconductors reserves the right to make changes at any time without notice, in order to improve design and supply the best possible product.

Philips Semiconductors and Philips Electronics North America Corporation reserve the right to make changes, without notice, in the products, including circuits, standard cells, and/or software, described or contained herein in order to improve design and/or performance. Philips Semiconductors assumes no responsibility or liability for the use of any of these products, conveys no license or title under any patent, copyright, or mask work right to these products, and makes no representations or warranties that these products are free from patent, copyright, or mask work right infringement, unless otherwise specified. Applications that are described herein for any of these products are for illustrative purposes only. Philips Semiconductors makes no representation or warranty that such applications will be suitable for the specified use without further testing or modification.

LIFE SUPPORT APPLICATIONS

Philips Semiconductors and Philips Electronics North America Corporation Products are not designed for use in life support appliances, devices, or systems where malfunction of a Philips Semiconductors and Philips Electronics North America Corporation Product can reasonably be expected to result in a personal injury. Philips Semiconductors and Philips Electronics North America Corporation customers using or selling Philips Semiconductors and Philips Electronics North America Corporation Products for use in such applications do so at their own risk and agree to fully indemnify Philips Semiconductors and Philips Electronics North America Corporation for any damages resulting from such improper use or sale.

Philips Semiconductors
811 East Arques Avenue
P.O. Box 3409
Sunnyvale, California 94088-3409
Telephone 800-234-7381

© Copyright Philips Electronics North America Corporation 1998
 All rights reserved. Printed in U.S.A.

print code

Date of release: 05-96

Document order number:

9397-750-04494

Let's make things better.