

# CD74HC257, CD74HCT257

## High Speed CMOS Logic Quad 2-Input Multiplexer with Three-State Non-Inverting Outputs

### Features

- **Buffered Inputs**
- **Typical Propagation Delay ( In to Output ) = 12ns at  $V_{CC} = 5V, C_L = 15pF, T_A = 25^\circ C$**
- **Fanout (Over Temperature Range)**
  - Standard Outputs . . . . . 10 LSTTL Loads
  - Bus Driver Outputs . . . . . 15 LSTTL Loads
- **Wide Operating Temperature Range . . .  $-55^\circ C$  to  $125^\circ C$**
- **Balanced Propagation Delay and Transition Times**
- **Significant Power Reduction Compared to LSTTL Logic ICs**
- **HC Types**
  - 2V to 6V Operation
  - High Noise Immunity:  $N_{IL} = 30\%, N_{IH} = 30\%$  of  $V_{CC}$  at  $V_{CC} = 5V$
- **HCT Types**
  - 4.5V to 5.5V Operation
  - Direct LSTTL Input Logic Compatibility,  $V_{IL} = 0.8V$  (Max),  $V_{IH} = 2V$  (Min)
  - CMOS Input Compatibility,  $I_I \leq 1\mu A$  at  $V_{OL}, V_{OH}$

### Description

The Harris CD74HC257 and CD74HCT257 are quad 2-input multiplexers which select four bits of data from two sources under the control of a common Select Input (S). The Output Enable input ( $\overline{OE}$ ) is active LOW. When  $\overline{OE}$  is HIGH, all of the outputs (1Y-4Y) are in the high impedance state regardless of all other input conditions.

Moving data from two groups of registers to four common output busses is a common use of the 257. The state of the Select input determines the particular register from which the data comes. It can also be used as a function generator.

### Ordering Information

PART NUMBER	TEMP. RANGE ( $^\circ C$ )	PACKAGE	PKG. NO.
CD74HC257E	-55 to 125	16 Ld PDIP	E16.3
CD74HCT257E	-55 to 125	16 Ld PDIP	E16.3
CD74HC257M	-55 to 125	16 Ld SOIC	M16.15
CD74HCT257M	-55 to 125	16 Ld SOIC	M16.15

#### NOTES:

1. When ordering, use the entire part number. Add the suffix 96 to obtain the variant in the tape and reel.
2. Wafer or die for this part number is available which meets all electrical specifications. Please contact your local sales office or Harris customer service for ordering information.

### Pinout

CD74HC257, CD74HCT257  
(PDIP, SOIC)  
TOP VIEW

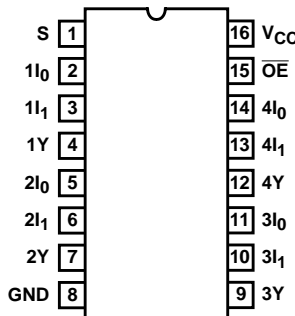

## CD74HC257, CD74HCT257

### Functional Diagram

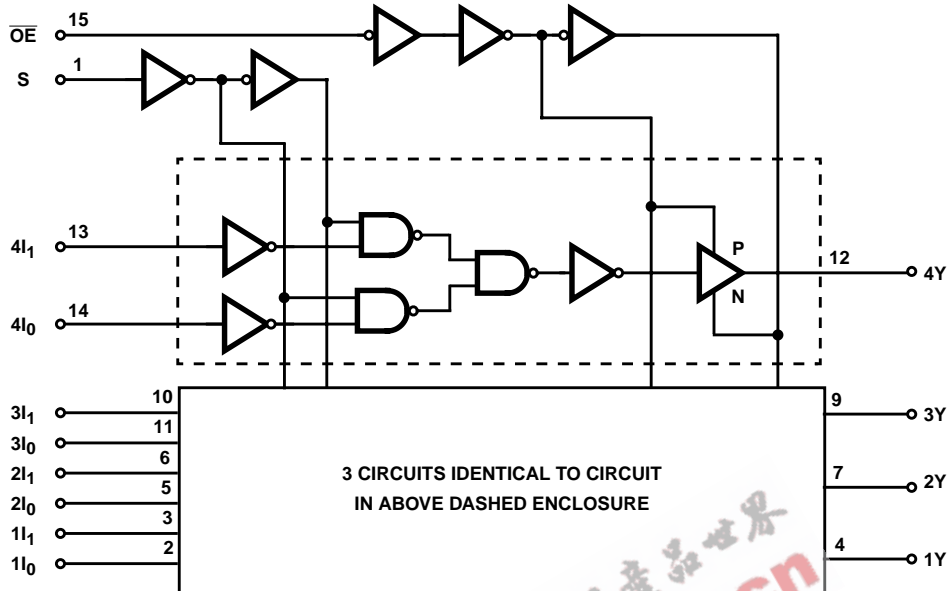

TRUTH TABLE

OUTPUT ENABLE	SELECT INPUT	DATA INPUTS		OUTPUT
$\overline{OE}$	S	$I_0$	$I_1$	Y
H	X	X	X	Z
L	L	L	X	L
L	L	H	X	H
L	H	X	L	L
L	H	X	H	H

**NOTE:**

- H = High Voltage Level
- L = Low Voltage Level
- X = Don't Care
- Z = High Impedance, OFF State

## CD74HC257, CD74HCT257

### Absolute Maximum Ratings

DC Supply Voltage, $V_{CC}$	-0.5V to 7V
DC Input Diode Current, $I_{IK}$	
For $V_I < -0.5V$ or $V_I > V_{CC} + 0.5V$	$\pm 20mA$
DC Output Diode Current, $I_{OK}$	
For $V_O < -0.5V$ or $V_O > V_{CC} + 0.5V$	$\pm 20mA$
DC Drain Current, per Output, $I_O$	
For $-0.5V < V_O < V_{CC} + 0.5V$	$\pm 35mA$
DC Output Source or Sink Current per Output Pin, $I_O$	
For $V_O > -0.5V$ or $V_O < V_{CC} + 0.5V$	$\pm 25mA$
DC $V_{CC}$ or Ground Current, $I_{CC}$	$\pm 70mA$

### Thermal Information

Thermal Resistance (Typical, Note 3)	$\theta_{JA}$ ( $^{\circ}C/W$ )
PDIP Package	90
SOIC Package	160
Maximum Junction Temperature	$150^{\circ}C$
Maximum Storage Temperature Range	$-65^{\circ}C$ to $150^{\circ}C$
Maximum Lead Temperature (Soldering 10s)	$300^{\circ}C$ (SOIC - Lead Tips Only)

### Operating Conditions

Temperature Range, $T_A$	$-55^{\circ}C$ to $125^{\circ}C$
Supply Voltage Range, $V_{CC}$	
HC Types	.2V to 6V
HCT Types	4.5V to 5.5V
DC Input or Output Voltage, $V_I, V_O$	0V to $V_{CC}$
Input Rise and Fall Time	
2V	1000ns (Max)
4.5V	500ns (Max)
6V	400ns (Max)

CAUTION: Stresses above those listed in "Absolute Maximum Ratings" may cause permanent damage to the device. This is a stress only rating and operation of the device at these or any other conditions above those indicated in the operational sections of this specification is not implied.

#### NOTE:

- $\theta_{JA}$  is measured with the component mounted on an evaluation PC board in free air.

### DC Electrical Specifications

PARAMETER	SYMBOL	TEST CONDITIONS			25°C			-40°C TO 85°C		-55°C TO 125°C		UNITS
		$V_I$ (V)	$I_O$ (mA)	$V_{CC}$ (V)	MIN	TYP	MAX	MIN	MAX	MIN	MAX	
<b>HC TYPES</b>												
High Level Input Voltage	$V_{IH}$	-	-	2	1.5	-	-	1.5	-	1.5	-	V
				4.5	3.15	-	-	3.15	-	3.15	-	V
				6	4.2	-	-	4.2	-	4.2	-	V
Low Level Input Voltage	$V_{IL}$	-	-	2	-	-	0.5	-	0.5	-	0.5	V
				4.5	-	-	1.35	-	1.35	-	1.35	V
				6	-	-	1.8	-	1.8	-	1.8	V
High Level Output Voltage CMOS Loads	$V_{OH}$	$V_{IH}$ or $V_{IL}$	-0.02	2	1.9	-	-	1.9	-	1.9	-	V
			-0.02	4.5	4.4	-	-	4.4	-	4.4	-	V
			-0.02	6	5.9	-	-	5.9	-	5.9	-	V
High Level Output Voltage TTL Loads	$V_{OH}$	$V_{IH}$ or $V_{IL}$	-6	4.5	3.98	-	-	3.84	-	3.7	-	V
			-7.8	6	5.48	-	-	5.34	-	5.2	-	V
Low Level Output Voltage CMOS Loads	$V_{OL}$	$V_{IH}$ or $V_{IL}$	0.02	2	-	-	0.1	-	0.1	-	0.1	V
			0.02	4.5	-	-	0.1	-	0.1	-	0.1	V
			0.02	6	-	-	0.1	-	0.1	-	0.1	V
Low Level Output Voltage TTL Loads	$V_{OL}$	$V_{IH}$ or $V_{IL}$	6	4.5	-	-	0.26	-	0.33	-	0.4	V
			7.8	6	-	-	0.26	-	0.33	-	0.4	V
Input Leakage Current	$I_I$	$V_{CC}$ or GND	-	6	-	-	$\pm 0.1$	-	$\pm 1$	-	$\pm 1$	$\mu A$

## CD74HC257, CD74HCT257

### DC Electrical Specifications (Continued)

PARAMETER	SYMBOL	TEST CONDITIONS		$V_{CC}$ (V)	25°C			-40°C TO 85°C		-55°C TO 125°C		UNITS
		$V_I$ (V)	$I_O$ (mA)		MIN	TYP	MAX	MIN	MAX	MIN	MAX	
Quiescent Device Current	$I_{CC}$	$V_{CC}$ or GND	0	6	-	-	8	-	80	-	160	$\mu$ A
Three-State Leakage Current	$I_{OZ}$	$V_{IL}$ or $V_{IH}$	-	6	-	-	$\pm 0.5$	-	$\pm 5$	-	$\pm 10$	$\mu$ A
<b>HCT TYPES</b>												
High Level Input Voltage	$V_{IH}$	-	-	4.5 to 5.5	2	-	-	2	-	2	-	V
Low Level Input Voltage	$V_{IL}$	-	-	4.5 to 5.5	-	-	0.8	-	0.8	-	0.8	V
High Level Output Voltage CMOS Loads	$V_{OH}$	$V_{IH}$ or $V_{IL}$	-0.02	4.5	4.4	-	-	4.4	-	4.4	-	V
High Level Output Voltage TTL Loads			-6	4.5	3.98	-	-	3.84	-	3.7	-	V
Low Level Output Voltage CMOS Loads	$V_{OL}$	$V_{IH}$ or $V_{IL}$	0.02	4.5	-	-	0.1	-	0.1	-	0.1	V
Low Level Output Voltage TTL Loads			6	4.5	-	-	0.26	-	0.33	-	0.4	V
Input Leakage Current	$I_I$	$V_{CC}$ to GND	0	5.5	-	-	$\pm 0.1$	-	$\pm 1$	-	$\pm 1$	$\mu$ A
Quiescent Device Current	$I_{CC}$	$V_{CC}$ or GND	0	5.5	-	-	8	-	80	-	160	$\mu$ A
Additional Quiescent Device Current Per Input Pin: 1 Unit Load (Note 4)	$\Delta I_{CC}$	$V_{CC}$ -2.1	-	4.5 to 5.5	-	100	360	-	450	-	490	$\mu$ A
Three-State Leakage Current	$I_{OZ}$	$V_{IL}$ or $V_{IH}$	-	5.5	-	-	$\pm 0.5$	-	$\pm 5$	-	$\pm 10$	$\mu$ A

NOTE:

4. For dual-supply systems theoretical worst case ( $V_I = 2.4V$ ,  $V_{CC} = 5.5V$ ) specification is 1.8mA.

### HCT Input Loading Table

INPUT	UNIT LOADS
Data	0.95
S	3
$\overline{OE}$	0.6

NOTE: Unit Load is  $\Delta I_{CC}$  limit specified in DC Electrical Specifications table, e.g., 360 $\mu$ A max at 25°C.

## CD74HC257, CD74HCT257

### Switching Specifications Input $t_r, t_f = 6\text{ns}$

PARAMETER	SYMBOL	TEST CONDITIONS	$V_{CC}$ (V)	25°C		-40°C TO 85°C	-55°C TO 125°C	UNITS
				TYP	MAX	MAX	MAX	
<b>HC TYPES</b>								
Propagation Delay In to Y	$t_{PLH}, t_{PHL}$	$C_L = 50\text{pF}$	2	-	150	190	225	ns
			4.5	-	30	38	45	ns
		$C_L = 15\text{pF}$	5	12	-	-	-	ns
		$C_L = 50\text{pF}$	6	-	26	33	38	ns
Propagation Delay S to Y	$t_{PLH}, t_{PHL}$	$C_L = 50\text{pF}$	2	-	175	220	265	ns
			4.5	-	35	44	53	ns
		$C_L = 15\text{pF}$	5	14	-	-	-	ns
		$C_L = 50\text{pF}$	6	-	30	37	45	ns
Propagation Delay $\overline{\text{OE}}$ to Y	$t_{PLZ}, t_{PHZ},$ $t_{PZL}, t_{PZH}$	$C_L = 50\text{pF}$	2	-	150	190	225	ns
			4.5	-	30	38	45	ns
		$C_L = 15\text{pF}$	5	12	-	-	-	ns
		$C_L = 50\text{pF}$	6	-	26	33	38	ns
Output Transition Times	$t_{TLH}, t_{THL}$	$C_L = 50\text{pF}$	2	-	60	75	90	ns
			4.5	-	12	15	18	ns
			6	-	10	13	15	ns
Input Capacitance	$C_I$	-	-	-	10	10	10	pF
Three-State Output Capacitance	$C_O$	-	-	-	20	20	20	pF
Power Dissipation Capacitance (Notes 5, 6)	$C_{PD}$	-	5	45	-	-	-	pF
<b>HCT TYPES</b>								
Propagation Delay In to Y	$t_{PLH}, t_{PHL}$	$C_L = 50\text{pF}$	4.5	-	33	41	50	ns
		$C_L = 15\text{pF}$	5	13	-	-	-	ns
Propagation Delay S to Y	$t_{PZL}, t_{PZH}$	$C_L = 50\text{pF}$	4.5	-	38	48	57	ns
		$C_L = 15\text{pF}$	5	12	-	-	-	ns
Propagation Delay $\overline{\text{OE}}$ to Y	$t_{PLZ}, t_{PHZ}$	$C_L = 50\text{pF}$	4.5	-	30	38	45	ns
		$C_L = 15\text{pF}$	5	16	-	-	-	ns
Output Transition Times	$t_{TLH}, t_{THL}$	$C_L = 50\text{pF}$	4.5	-	12	15	18	ns
Input Capacitance	$C_I$	-	-	-	10	10	10	pF
Three-State Output Capacitance	$C_O$	-	-	-	20	20	20	pF
Power Dissipation Capacitance (Notes 5, 6)	$C_{PD}$	-	5	45	-	-	-	pF

**NOTES:**

5.  $C_{PD}$  is used to determine the dynamic power consumption, per multiplexer.
6.  $P_D = V_{CC}^2 f_i (C_{PD} + C_L)$  where  $f_i$  = Input Frequency,  $C_L$  = Output Load Capacitance,  $V_{CC}$  = Supply Voltage.

# CD74HC257, CD74HCT257

## Test Circuits and Waveforms

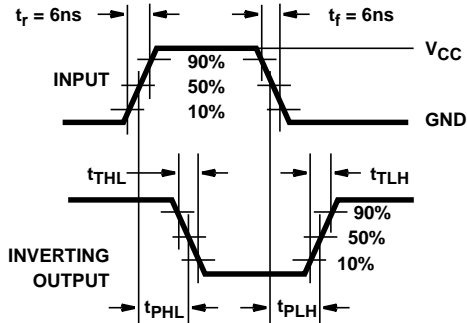

FIGURE 1. HC TRANSITION TIMES AND PROPAGATION DELAY TIMES, COMBINATION LOGIC

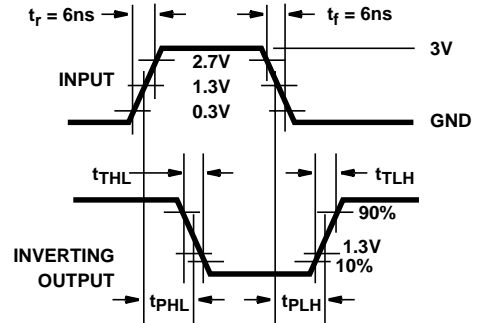

FIGURE 2. HCT TRANSITION TIMES AND PROPAGATION DELAY TIMES, COMBINATION LOGIC

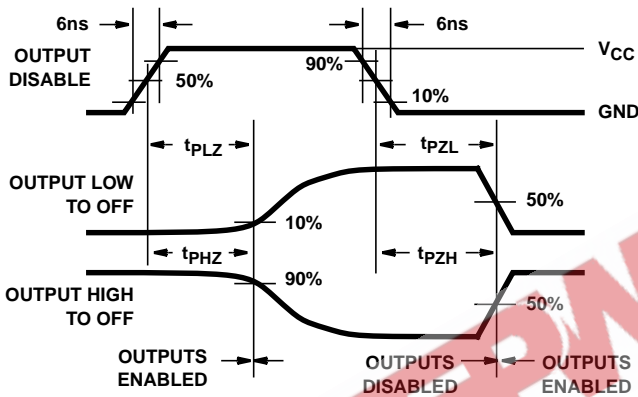

FIGURE 3. HC THREE-STATE PROPAGATION DELAY WAVEFORM

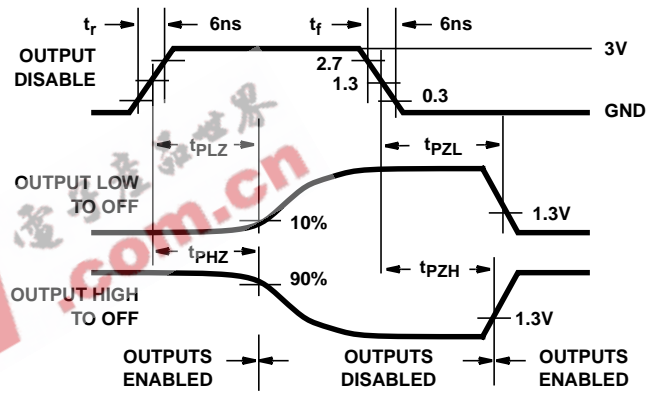
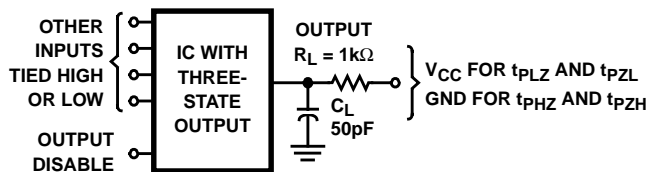

FIGURE 4. HCT THREE-STATE PROPAGATION DELAY WAVEFORM



NOTE: Open drain waveforms  $t_{PLZ}$  and  $t_{PZL}$  are the same as those for three-state shown on the left. The test circuit is Output  $R_L = 1k\Omega$  to  $V_{CC}$ ,  $C_L = 50pF$ .

FIGURE 5. HC AND HCT THREE-STATE PROPAGATION DELAY TEST CIRCUIT

## IMPORTANT NOTICE

Texas Instruments and its subsidiaries (TI) reserve the right to make changes to their products or to discontinue any product or service without notice, and advise customers to obtain the latest version of relevant information to verify, before placing orders, that information being relied on is current and complete. All products are sold subject to the terms and conditions of sale supplied at the time of order acknowledgement, including those pertaining to warranty, patent infringement, and limitation of liability.

TI warrants performance of its semiconductor products to the specifications applicable at the time of sale in accordance with TI's standard warranty. Testing and other quality control techniques are utilized to the extent TI deems necessary to support this warranty. Specific testing of all parameters of each device is not necessarily performed, except those mandated by government requirements.

CERTAIN APPLICATIONS USING SEMICONDUCTOR PRODUCTS MAY INVOLVE POTENTIAL RISKS OF DEATH, PERSONAL INJURY, OR SEVERE PROPERTY OR ENVIRONMENTAL DAMAGE ("CRITICAL APPLICATIONS"). TI SEMICONDUCTOR PRODUCTS ARE NOT DESIGNED, AUTHORIZED, OR WARRANTED TO BE SUITABLE FOR USE IN LIFE-SUPPORT DEVICES OR SYSTEMS OR OTHER CRITICAL APPLICATIONS. INCLUSION OF TI PRODUCTS IN SUCH APPLICATIONS IS UNDERSTOOD TO BE FULLY AT THE CUSTOMER'S RISK.

In order to minimize risks associated with the customer's applications, adequate design and operating safeguards must be provided by the customer to minimize inherent or procedural hazards.

TI assumes no liability for applications assistance or customer product design. TI does not warrant or represent that any license, either express or implied, is granted under any patent right, copyright, mask work right, or other intellectual property right of TI covering or relating to any combination, machine, or process in which such semiconductor products or services might be or are used. TI's publication of information regarding any third party's products or services does not constitute TI's approval, warranty or endorsement thereof.