

## 74VCX132

### Low Voltage Quad 2-Input NAND Gate with Schmitt Trigger Inputs and 3.6V Tolerant Inputs and Outputs

#### General Description

The VCX132 contains four 2-input NAND gates with Schmitt Trigger Inputs. The pin configuration and function are the same as the VCX00 except the inputs have hysteresis between the positive-going and negative-going input thresholds. This hysteresis is useful for transforming slowly switching input signals into sharply defined, jitter-free output signals. This product should be used where noise margin greater than that of conventional gates is required.

The VCX132 is designed for low voltage (1.4V to 3.6V)  $V_{CC}$  applications with I/O compatibility up to 3.6V.

This product is fabricated with an advanced CMOS technology to achieve high-speed operation while maintaining low CMOS power dissipation.

#### Features

- 1.4V to 3.6V  $V_{CC}$  supply operation
- 3.6V tolerant inputs and outputs
- $t_{PD}$ 
  - 3.3 ns max for 3.0V to 3.6V  $V_{CC}$
- Power-off high impedance inputs and outputs
- Static Drive ( $I_{OH}/I_{OL}$ )
  - ±24 mA @ 3.0V  $V_{CC}$
- Uses patented Quiet Series™ noise/EMI reduction circuitry
- Latchup performance exceeds JEDEC 78 conditions
- ESD performance:
  - Human body model > 2000V
  - Machine model > 250V
- Leadless Pb-Free DQFN package

#### Ordering Code:

Order Number	Package Number	Package Description
74VCX132M	M14A	14-Lead Small Outline Integrated Circuit (SOIC), JEDEC MS-012, 0.150" Narrow
74VCX132BQX (Note 1)	MLP014A	Pb-Free 14-Terminal Depopulated Quad Very-Thin Flat Pack No Leads (DQFN), JEDEC MO-241, 2.5 x 3.0mm
74VCX132MTC	MTC14	14-Lead Thin Shrink Small Outline Package (TSSOP), JEDEC MO-153, 4.4mm Wide

Devices also available in Tape and Reel. Specify by appending suffix letter "X" to the ordering code.  
Pb-Free package per JEDEC J-STD-020B.

**Note 1:** DQFN package available in Tape and Reel only.

Quiet Series™ is a trademark of Fairchild Semiconductor Corporation.

74VCX132 Low Voltage Quad 2-Input NAND Gate with Schmitt Trigger Inputs and 3.6V Tolerant Inputs and Outputs

**Logic Diagram**

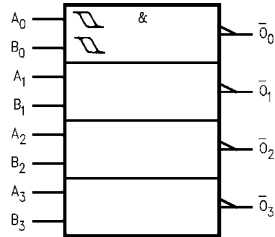

**Pin Descriptions**

Pin Name	Description
$A_n, B_n$	Inputs
$\bar{O}_n$	Outputs

**Connection Diagrams**

Pin Assignments for SOIC and TSSOP

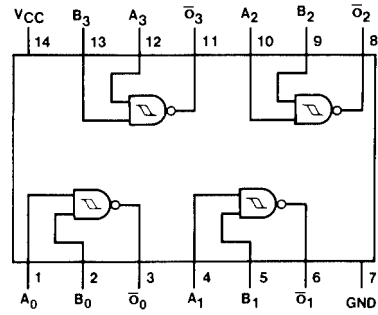

Pad Assignments for DQFN

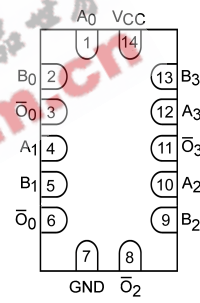

(Top View)

Absolute Maximum Ratings (Note 2)		Recommended Operating Conditions (Note 4)	
Supply Voltage ( $V_{CC}$ )	-0.5V to +4.6V	Power Supply	
DC Input Voltage ( $V_I$ )	-0.5V to 4.6V	Operating	1.4V to 3.6V
DC Output Voltage ( $V_O$ )		Input Voltage	-0.3V to 3.6V
HIGH or LOW State (Note 3)	-0.5V to $V_{CC} + 0.5V$	Output Voltage ( $V_O$ )	
$V_{CC} = 0V$	-0.5V to +4.6V	HIGH or LOW State	0V to $V_{CC}$
DC Input Diode Current ( $I_{IK}$ )		Output Current in $I_{OH}/I_{OL}$	
$V_I < 0V$	-50 mA	$V_{CC} = 3.0V$ to 3.6V	$\pm 24$ mA
DC Output Diode Current ( $I_{OK}$ )		$V_{CC} = 2.3V$ to 2.7V	$\pm 18$ mA
$V_O < 0V$	-50 mA	$V_{CC} = 1.65V$ to 2.3V	$\pm 6$ mA
$V_O > V_{CC}$	+50 mA	$V_{CC} = 1.4V$ to 1.6V	$\pm 2$ mA
DC Output Source/Sink Current ( $I_{OH}/I_{OL}$ )	$\pm 50$ mA	Free Air Operating Temperature ( $T_A$ )	-40°C to +85°C
DC $V_{CC}$ or Ground Current per Supply Pin ( $I_{CC}$ or Ground)	$\pm 100$ mA		
Storage Temperature ( $T_{STG}$ )	-65°C to +150°C		

**Note 2:** The "Absolute Maximum Ratings" are those values beyond which the safety of the device cannot be guaranteed. The device should not be operated at these limits. The parametric values defined in the Electrical Characteristics tables are not guaranteed at the absolute maximum ratings. The "Recommended Operating Conditions" table will define the conditions for actual device operation.

**Note 3:**  $I_O$  Absolute Maximum Rating must be observed.

**Note 4:** Floating or unused inputs must be held HIGH or LOW.

## DC Electrical Characteristics

Symbol	Parameter	Conditions	$V_{CC}$ (V)	Min	Max	Units
$V_{t+}$	HIGH Level Input Voltage		3.6		2.2	V
			3.0		2.0	
			2.3		1.6	
			1.6		1.2	
			1.4		1.2	
$V_{t-}$	LOW Level Input Voltage		3.6	0.8		V
			3.0	0.7		
			2.3	0.5		
			1.6	0.2		
			1.4	0.2		
$V_H$	Input Hysteresis		3.6	0.3	1.2	V
			3.0	0.3	1.2	
			2.3	0.3	1.0	
			1.6	0.15	0.9	
			1.4	0.15	0.9	
$V_{OH}$	HIGH Level Output Voltage	$I_{OH} = -100 \mu A$	2.7 - 3.6	$V_{CC} - 0.2$		V
		$I_{OH} = -12$ mA	2.7	2.2		
		$I_{OH} = -18$ mA	3.0	2.4		
		$I_{OH} = -24$ mA	3.0	2.2		
		$I_{OH} = -100 \mu A$	2.3 - 2.7	$V_{CC} - 0.2$		
		$I_{OH} = -6$ mA	2.3	2.0		
		$I_{OH} = -12$ mA	2.3	1.8		
		$I_{OH} = -18$ mA	2.3	1.7		
		$I_{OH} = -100 \mu A$	1.65 - 2.3	$V_{CC} - 0.2$		
		$I_{OH} = -6$ mA	1.65	1.25		
		$I_{OH} = -100 \mu A$	1.4 - 1.6	$V_{CC} - 0.2$		
		$I_{OH} = -2$ mA	1.4	1.05		

### DC Electrical Characteristics (Continued)

Symbol	Parameter	Conditions	V <sub>CC</sub> (V)	Min	Max	Units
V <sub>OL</sub>	LOW Level Output Voltage	I <sub>OL</sub> = 100 μA	2.7 - 3.6		0.2	V
		I <sub>OL</sub> = 12 μA	2.7		0.4	
		I <sub>OL</sub> = 18 mA	3.0		0.4	
		I <sub>OL</sub> = 24 mA	3.0		0.55	
		I <sub>OL</sub> = 100 μA	2.3 - 2.7		0.2	
		I <sub>OL</sub> = 12 mA	2.3		0.4	
		I <sub>OL</sub> = 18 mA	2.3		0.6	
I <sub>I</sub>	Input Leakage Current	0 ≤ V <sub>I</sub> ≤ 3.6V	1.4 - 3.6		±5.0	μA
		I <sub>OZ</sub>	3-STATE Output Leakage	0 ≤ V <sub>O</sub> ≤ 3.6V V <sub>I</sub> = V <sub>IH</sub> or V <sub>IL</sub>	1.4 - 3.6	
I <sub>OFF</sub>	Power Off Leakage Current	0 ≤ (V <sub>I</sub> , V <sub>O</sub> ) ≤ 3.6V	0		10.0	μA
I <sub>CC</sub>	Quiescent Supply Current	V <sub>I</sub> = V <sub>CC</sub> or GND V <sub>CC</sub> ≤ V <sub>I</sub> ≤ 3.6V	1.4 - 3.6		20.0	μA
ΔI <sub>CC</sub>	Increase in I <sub>CC</sub> per Input	V <sub>IH</sub> = V <sub>CC</sub> - 0.6V	2.7 - 3.6		750	μA

### AC Electrical Characteristics (Note 5)

Symbol	Parameter	Conditions	V <sub>CC</sub> (V)	T <sub>A</sub> = -40°C to +85°C		Units	Figure Number
				Min	Max		
t <sub>PHL</sub>	Propagation Delay	C <sub>L</sub> = 30 pF, R <sub>L</sub> = 500Ω	3.3 ± 0.3	0.6	3.3	ns	Figures 1, 2
t <sub>PLH</sub>			2.5 ± 0.2	0.8	4.1		
			1.8 ± 0.15	1.0	8.2		Figures 3, 4
		C <sub>L</sub> = 15 pF, R <sub>L</sub> = 2kΩ	1.5 ± 0.1	1.0	16.4		
t <sub>OSSL</sub>	Output-to-Output Skew (Note 6)	C <sub>L</sub> = 30 pF, R <sub>L</sub> = 500Ω	3.3 ± 0.3		0.5	ns	
t <sub>OSLH</sub>			2.5 ± 0.2		0.5		
			1.8 ± 0.15		0.75		
				1.5 ± 0.1			

**Note 5:** For C<sub>L</sub> = 50 pF, add approximately 300 ps to the AC maximum specification.

**Note 6:** Skew is defined as the absolute value of the difference between the actual propagation delay for any two separate outputs of the same device. The specification applies to any outputs switching in the same direction, either HIGH-to-LOW (t<sub>OSSL</sub>) or LOW-to-HIGH (t<sub>OSLH</sub>).

### Dynamic Switching Characteristics

Symbol	Parameter	Conditions	V <sub>CC</sub> (V)	T <sub>A</sub> = +25°C	Units
				Typical	
V <sub>OLP</sub>	Quiet Output Dynamic Peak V <sub>OL</sub>	C <sub>L</sub> = 30 pF, V <sub>IH</sub> = V <sub>CC</sub> , V <sub>IL</sub> = 0V	1.8	0.25	V
			2.5	0.6	
			3.3	0.8	
V <sub>OLV</sub>	Quiet Output Dynamic Valley V <sub>OL</sub>	C <sub>L</sub> = 30 pF, V <sub>IH</sub> = V <sub>CC</sub> , V <sub>IL</sub> = 0V	1.8	-0.25	V
			2.5	-0.6	
			3.3	-0.8	
V <sub>OHV</sub>	Quiet Output Dynamic Valley V <sub>OH</sub>	C <sub>L</sub> = 30 pF, V <sub>IH</sub> = V <sub>CC</sub> , V <sub>IL</sub> = 0V	1.8	1.5	V
			2.5	1.9	
			3.3	2.2	

### Capacitance

Symbol	Parameter	Conditions	T <sub>A</sub> = +25°C	Units
			Typical	
C <sub>IN</sub>	Input Capacitance	V <sub>I</sub> = 0V or V <sub>CC</sub> , V <sub>CC</sub> = 1.8V, 2.5V or 3.3V	6.0	pF
C <sub>OUT</sub>	Output Capacitance	V <sub>I</sub> = 0V or V <sub>CC</sub> , V <sub>CC</sub> = 1.8V, 2.5V or 3.3V	7.0	pF
C <sub>PD</sub>	Power Dissipation Capacitance	V <sub>I</sub> = 0V or V <sub>CC</sub> , f = 10MHz, V <sub>CC</sub> = 1.8V, 2.5V or 3.3V	20.0	pF

### AC Loading and Waveforms (V<sub>CC</sub> 3.3V ± 0.3V to 1.8V ± 0.15V)

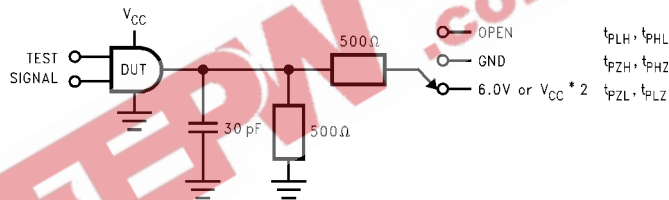

FIGURE 1. AC Test Circuit

TEST	SWITCH
t <sub>PLH</sub> , t <sub>PHL</sub>	Open

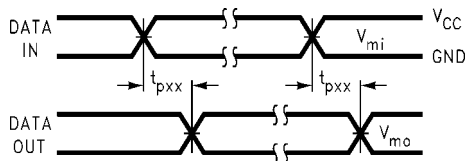
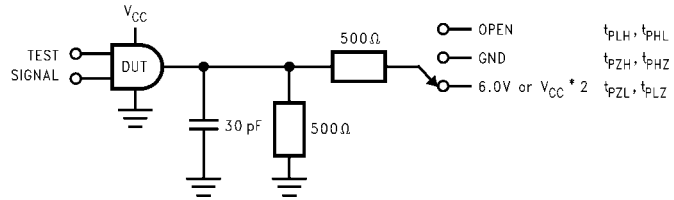

FIGURE 2. Waveform for Inverting and Non-inverting Functions

Symbol	V <sub>CC</sub>		
	3.3V ± 0.3V	2.5V ± 0.2V	1.8V ± 0.15V
V <sub>mi</sub>	1.5V	V <sub>CC</sub> /2	V <sub>CC</sub> /2
V <sub>mo</sub>	1.5V	V <sub>CC</sub> /2	V <sub>CC</sub> /2

AC Loading and Waveforms ( $V_{CC} 1.5V \pm 0.1V$ )

TEST	SWITCH
$t_{PLH}, t_{PHL}$	Open
$t_{PZL}, t_{PLZ}$	$V_{CC} \times 2$ at $V_{CC} = 1.5V \pm 0.1V$
$t_{PZH}, t_{PHZ}$	GND

FIGURE 3. AC Test Circuit

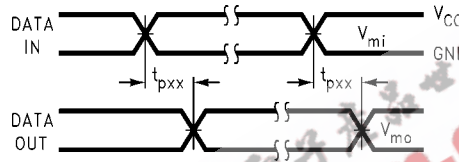

FIGURE 4. Waveform for Inverting and Non-inverting Functions

Symbol	$V_{CC}$
	$1.5V \pm 0.1V$
$V_{mi}$	$V_{CC}/2$
$V_{mo}$	$V_{CC}/2$

### Tape and Reel Specification

Tape Format for DQFN

Package Designator	Tape Section	Number Cavities	Cavity Status	Cover Tape Status
BQX	Leader (Start End)	125 (typ)	Empty	Sealed
	Carrier	2500/3000	Filled	Sealed
	Trailer (Hub End)	75 (typ)	Empty	Sealed

**TAPE DIMENSIONS** inches (millimeters)

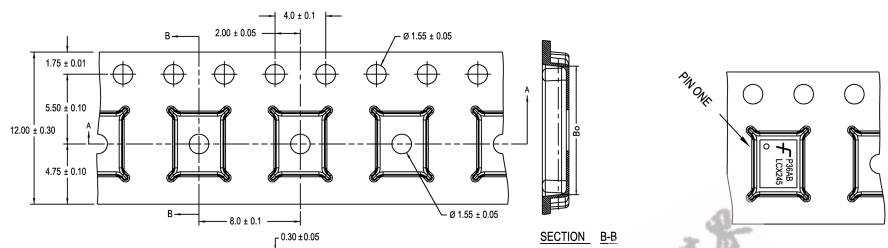

PKG. SIZE	DIM.A <sub>0</sub>	DIM.B <sub>0</sub>	DIM.K <sub>0</sub>
3.5 X 4.5	3.8 ± 0.1	4.8 ± 0.1	0.9 ± 0.1
3.0 X 3.0	3.3 ± 0.1	3.3 ± 0.1	0.9 ± 0.1
2.5 X 4.5	2.8 ± 0.1	4.8 ± 0.1	0.9 ± 0.1
2.5 X 3.5	2.8 ± 0.1	3.8 ± 0.1	0.9 ± 0.1
2.5 X 3.0	2.8 ± 0.1	3.3 ± 0.1	0.9 ± 0.1
2.5 X 2.5	2.8 ± 0.1	2.8 ± 0.1	0.9 ± 0.1

DIMENSIONS ARE IN MILLIMETERS

NOTES: unless otherwise specified

- Cumulative pitch for feeding holes and cavities (chip pockets) not to exceed 0.008[0.20] over 10 pitch span.
- Smallest allowable bending radius.
- Thru hole inside cavity is centered within cavity.
- Tolerance is ±0.002[0.05] for these dimensions on all 12mm tapes.
- A<sub>0</sub> and B<sub>0</sub> measured on a plane 0.120[0.30] above the bottom of the pocket.
- K<sub>0</sub> measured from a plane on the inside bottom of the pocket to the top surface of the carrier.
- Pocket position relative to sprocket hole measured as true position of pocket. Not pocket hole.
- Controlling dimension is millimeter. Dimension in inches rounded.

**REEL DIMENSIONS** inches (millimeters)

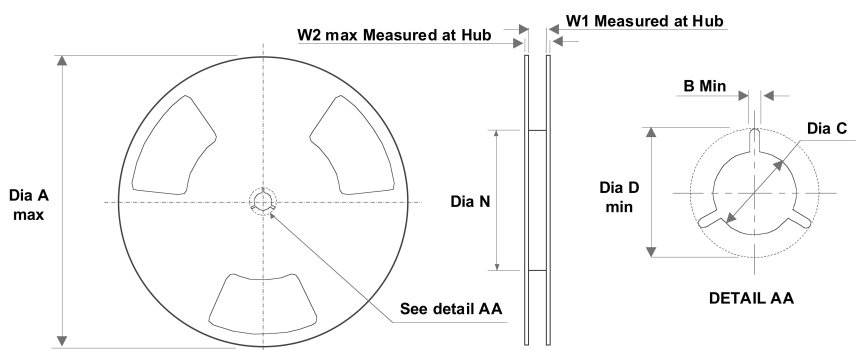

Tape Size	A	B	C	D	N	W1	W2
12 mm	13.0 (330)	0.059 (1.50)	0.512 (13.00)	0.795 (20.20)	7.008 (178)	0.488 (12.4)	0.724 (18.4)

**Physical Dimensions** inches (millimeters) unless otherwise noted

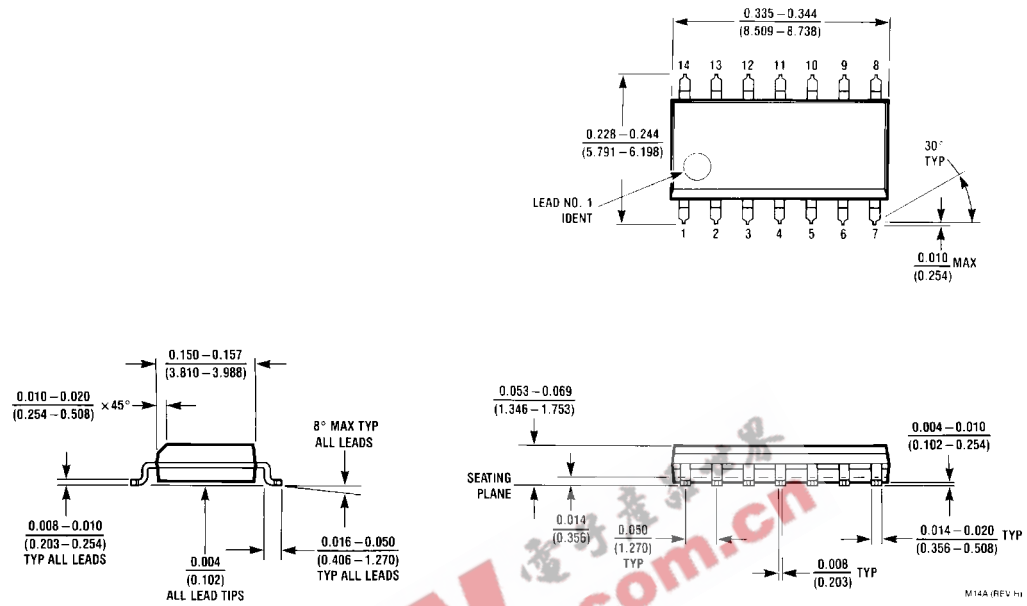

14-Lead Small Outline Integrated Circuit (SOIC), JEDEC MS-012, 0.150" Narrow  
Package Number M14A



**Physical Dimensions** inches (millimeters) unless otherwise noted (Continued)

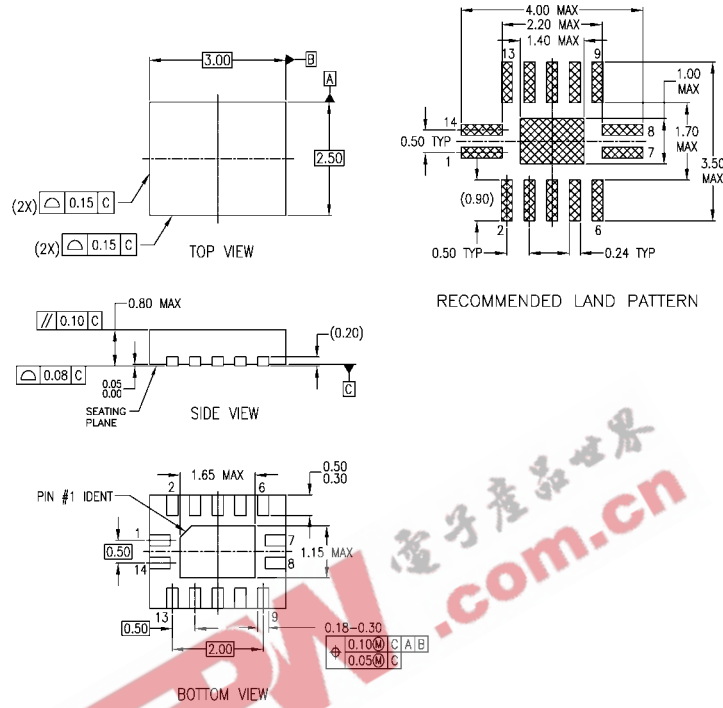

NOTES:

- A. CONFORMS TO JEDEC REGISTRATION MO-241, VARIATION AA
- B. DIMENSIONS ARE IN MILLIMETERS.
- C. DIMENSIONS AND TOLERANCES PER ASME Y14.5M, 1994

MLP014ArevA

**Pb-Free 14-Terminal Depopulated Quad Very-Thin Flat Pack No Leads (DQFN), JEDEC MO-241, 2.5 x 3.0mm  
Package Number MLP014A**

### Physical Dimensions inches (millimeters) unless otherwise noted (Continued)

**LAND PATTERN RECOMMENDATION**

**DETAIL A**

**NOTES:**

- CONFORMS TO JEDEC REGISTRATION MO-153, VARIATION AB, REF NOTE 6, DATED 7/93
- DIMENSIONS ARE IN MILLIMETERS
- DIMENSIONS ARE EXCLUSIVE OF BURRS, MOLD FLASH, AND TIE BAR EXTRUSIONS
- DIMENSIONING AND TOLERANCES PER ANSI Y14.5M, 1992

MTC14revD

**14-Lead Thin Shrink Small Outline Package (TSSOP), JEDEC MO-153, 4.4mm Wide Package Number MTC14**

Fairchild does not assume any responsibility for use of any circuitry described, no circuit patent licenses are implied and Fairchild reserves the right at any time without notice to change said circuitry and specifications.

**LIFE SUPPORT POLICY**

FAIRCHILD'S PRODUCTS ARE NOT AUTHORIZED FOR USE AS CRITICAL COMPONENTS IN LIFE SUPPORT DEVICES OR SYSTEMS WITHOUT THE EXPRESS WRITTEN APPROVAL OF THE PRESIDENT OF FAIRCHILD SEMICONDUCTOR CORPORATION. As used herein:

- Life support devices or systems are devices or systems which, (a) are intended for surgical implant into the body, or (b) support or sustain life, and (c) whose failure to perform when properly used in accordance with instructions for use provided in the labeling, can be reasonably expected to result in a significant injury to the user.
- A critical component in any component of a life support device or system whose failure to perform can be reasonably expected to cause the failure of the life support device or system, or to affect its safety or effectiveness.

[www.fairchildsemi.com](http://www.fairchildsemi.com)