

74HC/HCT32  
SSI

QUAD 2-INPUT OR GATE

FEATURES

- Output capability: standard
- I<sub>CC</sub> category: SSI

GENERAL DESCRIPTION

The 74HC/HCT32 are high-speed Si-gate CMOS devices and are pin compatible with low power Schottky TTL (LSSTTL). They are specified in compliance with JEDEC standard no. 7A. The 74HC/HCT32 provide the 2-input OR function.

SYMBOL	PARAMETER	CONDITIONS	TYPICAL		UNIT
			HC	HCT	
t <sub>PHL</sub> / t <sub>PLH</sub>	propagation delay nA, nB to nY	C <sub>L</sub> = 15 pF V <sub>CC</sub> = 5 V	6	9	ns
C <sub>I</sub>	input capacitance		3.5	3.5	pF
CPD	power dissipation capacitance per gate	notes 1 and 2	16	28	pF

GND = 0 V; T<sub>amb</sub> = 25 °C; t<sub>r</sub> = t<sub>f</sub> = 6 ns

Notes

1. CPD is used to determine the dynamic power dissipation (P<sub>D</sub> in μW):  

$$P_D = CPD \times V_{CC}^2 \times f_i + \sum (C_L \times V_{CC}^2 \times f_o)$$
 where:  
 f<sub>i</sub> = input frequency in MHz      C<sub>L</sub> = output load capacitance in pF  
 f<sub>o</sub> = output frequency in MHz      V<sub>CC</sub> = supply voltage in V  
 Σ (C<sub>L</sub> × V<sub>CC</sub><sup>2</sup> × f<sub>o</sub>) = sum of outputs
2. For HC the condition is V<sub>I</sub> = GND to V<sub>CC</sub>  
 For HCT the condition is V<sub>I</sub> = GND to V<sub>CC</sub> - 1.5 V

PACKAGE OUTLINES

14-lead DIL; plastic (SOT27).  
 14-lead mini-pack; plastic (SO14; SOT108A).

PIN DESCRIPTION

PIN NO.	SYMBOL	NAME AND FUNCTION
1, 4, 9, 12	1A to 4A	data inputs
2, 5, 10, 13	1B to 4B	data inputs
3, 6, 8, 11	1Y to 4Y	data outputs
7	GND	ground (0 V)
14	V <sub>CC</sub>	positive supply voltage

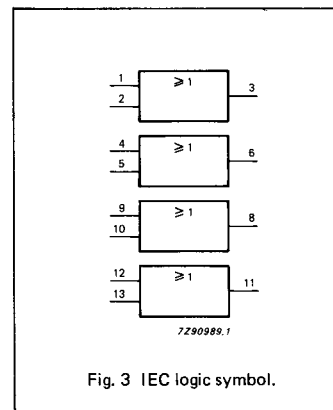
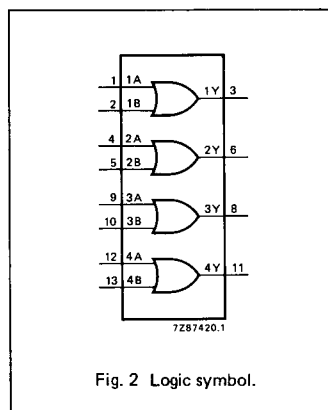
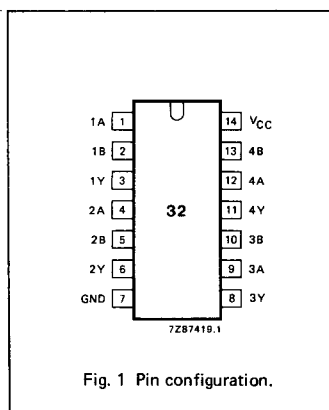

74HC/HCT32  
SSI

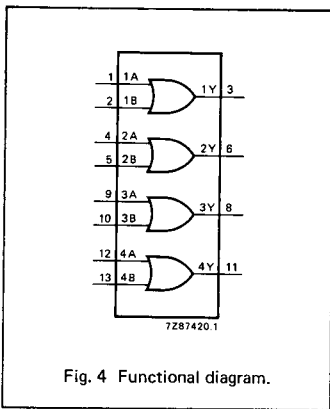

Fig. 4 Functional diagram.

FUNCTION TABLE

INPUTS		OUTPUT
nA	nB	nY
L	L	L
L	H	H
H	L	H
H	H	H

H = HIGH voltage level  
L = LOW voltage level

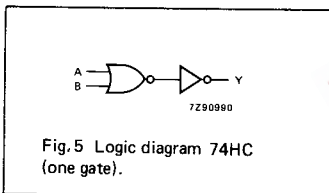

Fig. 5 Logic diagram 74HC (one gate).

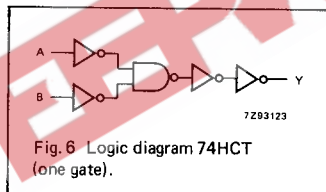

Fig. 6 Logic diagram 74HCT (one gate).

DC CHARACTERISTICS FOR 74HC

For the DC characteristics see chapter "HCMOS family characteristics", section "Family specifications".

Output capability: standard

I<sub>CC</sub> category: SSI

AC CHARACTERISTICS FOR 74HC

GND = 0 V; t<sub>r</sub> = t<sub>f</sub> = 6 ns; C<sub>L</sub> = 50 pF

SYMBOL	PARAMETER	T <sub>amb</sub> (°C)						UNIT	TEST CONDITIONS		
		74HC							V <sub>CC</sub> V	WAVEFORMS	
		+25			-40 to +85		-40 to +125				
		min.	typ.	max.	min.	max.	min.				max.
t <sub>PHL</sub> / t <sub>PLH</sub>	propagation delay nA, nB to nY		22 8 6	90 18 15		115 23 20		135 27 23	ns	2.0 4.5 6.0	Fig. 7
t <sub>THL</sub> / t <sub>TLH</sub>	output transition time		19 7 6	75 15 13		95 19 16		110 22 19	ns	2.0 4.5 6.0	Fig. 7

**DC CHARACTERISTICS FOR 74HCT**

For the DC characteristics see chapter "HCMOS family characteristics", section "Family specifications".

Output capability: standard  
I<sub>CC</sub> category: SSI

**Note to HCT types**

The value of additional quiescent supply current ( $\Delta I_{CC}$ ) for a unit load of 1 is given in the family specifications.  
To determine  $\Delta I_{CC}$  per input, multiply this value by the unit load coefficient shown in the table below.

INPUT	UNIT LOAD COEFFICIENT
nA, nB	1.20

**AC CHARACTERISTICS FOR 74HCT**

GND = 0 V;  $t_r = t_f = 6$  ns;  $C_L = 50$  pF

SYMBOL	PARAMETER	T <sub>amb</sub> (°C)						UNIT	TEST CONDITIONS	
		74HCT							V <sub>CC</sub>	WAVEFORMS
		+25			-40 to +85		-40 to +125			
min.	typ.	max.	min.	max.	min.	max.				
t <sub>PHL</sub> / t <sub>PLH</sub>	propagation delay nA, nB to nY	11	24		30		36	ns	4.5	Fig. 7
t <sub>THL</sub> / t <sub>TLH</sub>	output transition time	7	15		19		22	ns	4.5	Fig. 7

74HC/HCT32  
SSI

AC WAVEFORMS

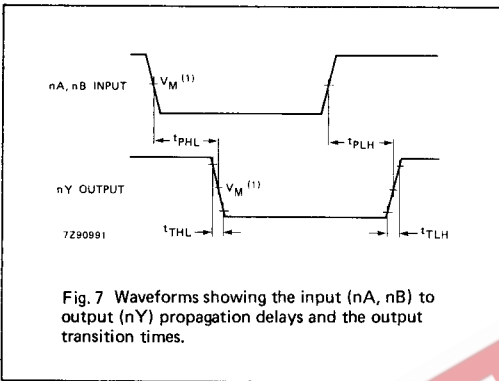

Note to AC waveforms

(1) HC :  $V_M = 50\%$ ;  $V_I = \text{GND to } V_{CC}$ .  
HCT:  $V_M = 1.3 \text{ V}$ ;  $V_I = \text{GND to } 3 \text{ V}$ .

电子产品世界  
EEPW.com.cn