

## 74VCX08

### Low Voltage Quad 2-Input AND Gate with 3.6V Tolerant Inputs and Outputs

#### General Description

The VCX08 contains four 2-input AND gates. This product is designed for low voltage (1.2V to 3.6V)  $V_{CC}$  applications with I/O compatibility up to 3.6V

The VCX08 is fabricated with an advanced CMOS technology to achieve high-speed operation while maintaining low CMOS power dissipation.

#### Features

- 1.2V to 3.6V  $V_{CC}$  supply operation
- 3.6V tolerant inputs and outputs
- $t_{PD}$   
2.8 ns max for 3.0V to 3.6V  $V_{CC}$
- Power-off high impedance inputs and outputs
- Static Drive ( $I_{OH}/I_{OL}$ )  
 $\pm 24$  mA @ 3.0V  $V_{CC}$
- Uses patented Quiet Series™ noise/EMI reduction circuitry
- Latchup performance exceeds 300 mA
- ESD performance:  
Human body model > 2000V  
Machine model > 250V
- Leadless Pb-Free DQFN package

#### Ordering Code:

Order Number	Package Number	Package Description
74VCX08M (Note 1)	M14A	14-Lead Small Outline Integrated Circuit (SOIC), JEDEC MS-012, 0.150" Narrow
74VCX08BQX (Note 2)	MLP014A	Pb-Free 14-Terminal Depopulated Quad Very-Thin Flat Pack No Leads (DQFN), JEDEC MO-241, 2.5 x 3.0mm
74VCX08MTC (Note 1)	MTC14	14-Lead Thin Shrink Small Outline Package (TSSOP), JEDEC MO-153, 4.4mm Wide
74VCX08MTCX_NL (Note 3)	MTC14	Pb-Free 14-Lead Thin Shrink Small Outline Package (TSSOP), JEDEC MO-153, 4.4mm Wide

Pb-Free package per JEDEC J-STD-020B.

**Note 1:** Devices also available in Tape and Reel. Specify by appending the suffix letter "X" to the ordering code.

**Note 2:** DQFN package available in Tape and Reel only.

**Note 3:** "\_NL" indicates Pb-Free package (per JEDEC J-STD-020B). Device available in Tape and Reel only.

Quiet Series™ is a trademark of Fairchild Semiconductor Corporation.

74VCX08 Low Voltage Quad 2-Input AND Gate with 3.6V Tolerant Inputs and Outputs

**Logic Symbol**

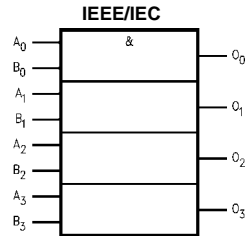

**Connection Diagrams**

Pin Assignments for SOIC and TSSOP

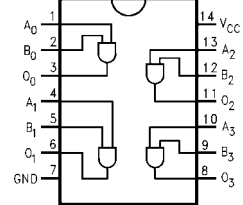

**Pin Descriptions**

Pin Names	Description
A <sub>n</sub> , B <sub>n</sub>	Inputs
O <sub>n</sub>	Outputs

Pad Assignments for DQFN

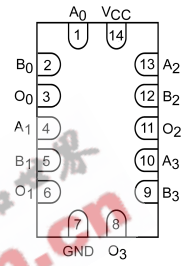

(Top View)



Absolute Maximum Ratings (Note 4)		Recommended Operating Conditions (Note 6)	
Supply Voltage ( $V_{CC}$ )	-0.5V to +4.6V	Power Supply	
DC Input Voltage ( $V_I$ )	-0.5V to +4.6V	Operating	1.2V to 3.6V
Output Voltage ( $V_O$ )		Input Voltage	-0.3V to 3.6V
HIGH or LOW State (Note 5)	-0.5V to $V_{CC} + 0.5V$	Output Voltage ( $V_O$ )	
$V_{CC} = 0V$	-0.5V to +4.6V	HIGH or LOW State	0V to $V_{CC}$
DC Input Diode Current ( $I_{IK}$ )		Output Current in $I_{OH}/I_{OL}$	
$V_I < 0V$	-50 mA	$V_{CC} = 3.0V$ to 3.6V	$\pm 24$ mA
DC Output Diode Current ( $I_{OK}$ )		$V_{CC} = 2.3V$ to 2.7V	$\pm 18$ mA
$V_O < 0V$	-50 mA	$V_{CC} = 1.65V$ to 2.3V	$\pm 6$ mA
$V_O > V_{CC}$	+50 mA	$V_{CC} = 1.4V$ to 1.6V	$\pm 2$ mA
DC Output Source/Sink Current ( $I_{OH}/I_{OL}$ )	+50 mA	$V_{CC} = 1.2V$	$\pm 100$ $\mu A$
DC $V_{CC}$ or Ground Current per	$\pm 100$ mA	Free Air Operating Temperature ( $T_A$ )	-40°C to +85°C
Supply Pin ( $I_{CC}$ or Ground)		Minimum Input Edge Rate ( $\Delta t/\Delta V$ )	
Storage Temperature Range ( $T_{stg}$ )	-65°C to +150°C	$V_{in} = 0.8V$ to 2.0V, $V_{CC} = 3.0V$	10 ns/V

**Note 4:** The Absolute Maximum Ratings are those values beyond which the safety of the device cannot be guaranteed. The device should not be operated at these limits. The parametric values defined in the Electrical Characteristics tables are not guaranteed at the Absolute Maximum Ratings. The "Recommended Operating Conditions" table will define the conditions for actual device operation.

**Note 5:**  $I_O$  Absolute Maximum Rating must be observed.

**Note 6:** Floating or unused inputs must be held HIGH or LOW

### DC Electrical Characteristics

Symbol	Parameter	Conditions	$V_{CC}$ (V)	Min	Max	Units
$V_{IH}$	HIGH Level Input Voltage		2.7 to 3.6	2.0		V
			2.3 to 2.7	1.6		
			1.65 to 2.3	$0.65 \times V_{CC}$		
			1.4 to 1.6	$0.65 \times V_{CC}$		
			1.2	$0.65 \times V_{CC}$		
$V_{IL}$	LOW Level Input Voltage		2.7 to 3.6		0.8	V
			2.3 to 2.7		0.7	
			1.65 to 2.3		$0.35 \times V_{CC}$	
			1.4 to 1.6		$0.35 \times V_{CC}$	
			1.2		$0.05 \times V_{CC}$	
$V_{OH}$	HIGH Level Output Voltage	$I_{OH} = -100 \mu A$ $I_{OH} = -12$ mA $I_{OH} = -18$ mA $I_{OH} = -24$ mA	2.7 to 3.6	$V_{CC} - 0.2$		V
			2.7	2.2		
			3.0	2.4		
			3.0	2.2		
		$I_{OH} = -100 \mu A$ $I_{OH} = -6$ mA $I_{OH} = -12$ mA $I_{OH} = -18$ mA	2.3 to 2.7	$V_{CC} - 0.2$		
			2.3	2.0		
			2.3	1.8		
			2.3	1.7		
		$I_{OH} = -100 \mu A$ $I_{OH} = -6$ mA	1.65 to 2.3	$V_{CC} - 0.2$		
			1.65	1.25		
		$I_{OH} = -100 \mu A$ $I_{OH} = -2$ mA	1.4 to 1.6	$V_{CC} - 0.2$		
			1.4	1.05		
		$I_{OH} = -100 \mu A$	1.2	$V_{CC} - 0.2$		

### DC Electrical Characteristics (Continued)

Symbol	Parameter	Conditions	V <sub>CC</sub> (V)	Min	Max	Units
V <sub>OL</sub>	LOW Level Output Voltage	I <sub>OL</sub> = 100 μA	2.7 to 3.6		0.2	V
		I <sub>OL</sub> = 12 mA	2.7		0.4	
		I <sub>OL</sub> = 18 mA	3.0		0.4	
		I <sub>OL</sub> = 24 mA	3.0		0.55	
		I <sub>OL</sub> = 100 μA	2.3 to 2.7		0.2	
		I <sub>OL</sub> = 12 mA	2.3		0.4	
		I <sub>OL</sub> = 18 mA	2.3		0.6	
		I <sub>OL</sub> = 100 μA	1.65 to 2.3		0.2	
	I <sub>OL</sub> = 6 mA	1.65		0.2		
	I <sub>OL</sub> = 100 μA	1.4 to 1.6		0.2		
	I <sub>OL</sub> = 2 mA	1.4		0.35		
	I <sub>OL</sub> = 100 μA	1.2		0.05		
I <sub>I</sub>	Input Leakage Current	0 ≤ V <sub>I</sub> ≤ 3.6V	1.2 to 3.6		±5.0	μA
I <sub>OFF</sub>	Power Off Leakage Current	0 ≤ (V <sub>I</sub> , V <sub>O</sub> ) ≤ 3.6V	0		10	μA
I <sub>CC</sub>	Quiescent Supply Current	V <sub>I</sub> = V <sub>CC</sub> or GND V <sub>CC</sub> ≤ V <sub>I</sub> ≤ 3.6V	1.2 to 3.6 1.2 to 3.6		20 ±20	μA
ΔI <sub>CC</sub>	Increase in I <sub>CC</sub> per Input	V <sub>IH</sub> = V <sub>CC</sub> - 0.6V	2.7 to 3.6		750	μA

### AC Electrical Characteristics (Note 7)

Symbol	Parameter	Conditions	V <sub>CC</sub> (V)	T <sub>A</sub> = -40°C to +85°C		Units	Figure Number	
				Min	Max			
t <sub>PHL</sub> t <sub>PLH</sub>	Propagation Delay	C <sub>L</sub> = 30 pF, R <sub>L</sub> = 500Ω	3.3 ± 0.3	0.6	2.8	ns	Figures 1, 2	
				2.5 ± 0.2	3.7			
				1.8 ± 0.15	7.4			
				1.5 ± 0.1	14.8			
		C <sub>L</sub> = 15 pF, R <sub>L</sub> = 2kΩ		1.0	37.0		Figures 3, 4	
				1.2				
t <sub>OSSL</sub> t <sub>OSLH</sub>	Output to Output Skew (Note 8)	C <sub>L</sub> = 30 pF, R <sub>L</sub> = 500Ω	3.3 ± 0.3		0.5	ns		
					0.5			
					0.75			
				C <sub>L</sub> = 15 pF, R <sub>L</sub> = 2kΩ	1.5 ± 0.1			1.5
					1.2			1.5

**Note 7:** For C<sub>L</sub> = pF, add approximately 300 ps to the AC maximum specification.

**Note 8:** Skew is defined as the absolute value of the difference between the actual propagation delay for any two separate outputs of the same device. The specification applies to any outputs switching in the same direction, either HIGH-to-LOW (t<sub>OSSL</sub>) or LOW-to-HIGH (t<sub>OSLH</sub>).

### Dynamic Switching Characteristics

Symbol	Parameter	Conditions	V <sub>CC</sub> (V)	T <sub>A</sub> = 25°C	Units
				Typical	
V <sub>OLP</sub>	Quiet Output Dynamic Peak V <sub>OL</sub>	C <sub>L</sub> = 30 pF, V <sub>IH</sub> = V <sub>CC</sub> , V <sub>IL</sub> = 0V	1.8	0.25	V
			2.5	0.6	
			3.3	0.8	
V <sub>OLV</sub>	Quiet Output Dynamic Valley V <sub>OL</sub>	C <sub>L</sub> = 30 pF, V <sub>IH</sub> = V <sub>CC</sub> , V <sub>IL</sub> = 0V	1.8	-0.25	V
			2.5	-0.6	
			3.3	-0.8	
V <sub>OHV</sub>	Quiet Output Dynamic Valley V <sub>OH</sub>	C <sub>L</sub> = 30 pF, V <sub>IH</sub> = V <sub>CC</sub> , V <sub>IL</sub> = 0V	1.8	1.5	V
			2.5	1.9	
			3.3	2.2	

### Capacitance

Symbol	Parameter	Conditions	T <sub>A</sub> = +25°C	Units
			Typical	
C <sub>IN</sub>	Input Capacitance	V <sub>I</sub> = 0V or V <sub>CC</sub> , V <sub>CC</sub> = 1.8V, 2.5V or 3.3V	6.0	pF
C <sub>OUT</sub>	Output Capacitance	V <sub>I</sub> = 0V or V <sub>CC</sub> , V <sub>CC</sub> = 1.8V, 2.5V or 3.3V	7.0	pF
C <sub>PD</sub>	Power Dissipation Capacitance	V <sub>I</sub> = 0V or V <sub>CC</sub> , f = 10 MHz, V <sub>CC</sub> = 1.8V, 2.5V or 3.3V	20.0	pF

### AC Loading and Waveforms (V<sub>CC</sub> 3.3V ± 0.3V to 1.8V ± 0.15V)

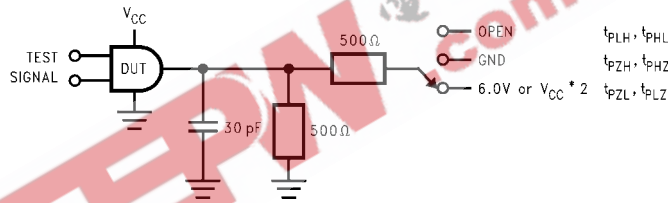

FIGURE 1. AC Test Circuit

TEST	SWITCH
t <sub>PLH</sub> , t <sub>PHL</sub>	Open

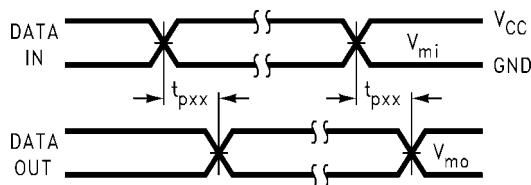
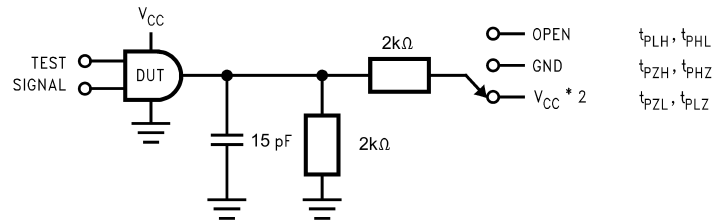

FIGURE 2. Waveform for Inverting and Non-inverting Functions

Symbol	V <sub>CC</sub>		
	3.3V ± 0.3V	2.5V ± 0.2V	1.8V ± 0.15V
V <sub>mi</sub>	1.5V	V <sub>CC</sub> /2	V <sub>CC</sub> /2
V <sub>mo</sub>	1.5V	V <sub>CC</sub> /2	V <sub>CC</sub> /2

AC Loading and Waveforms ( $V_{CC} 1.5 \pm 0.1V$  to  $1.2V$ )

TEST	SWITCH
$t_{PLH}, t_{PHL}$	Open
$t_{PZL}, t_{PLZ}$	$V_{CC} * 2$ at $V_{CC} = 1.5V \pm 0.1V$
$t_{PZH}, t_{PHZ}$	GND

FIGURE 3. AC Test Circuit

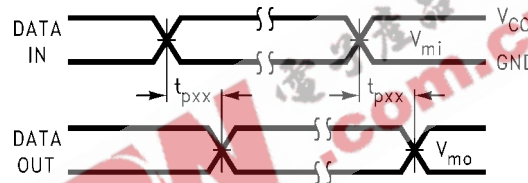

FIGURE 4. Waveform for Inverting and Non-Inverting Functions

Symbol	$V_{CC}$
	$1.5V \pm 0.1V$
$V_{mi}$	$V_{CC}/2$
$V_{mo}$	$V_{CC}/2$

### Tape and Reel Specification

Tape Format for DQFN

Package Designator	Tape Section	Number Cavities	Cavity Status	Cover Tape Status
BQX	Leader (Start End)	125 (typ)	Empty	Sealed
	Carrier	3000	Filled	Sealed
	Trailer (Hub End)	75 (typ)	Empty	Sealed

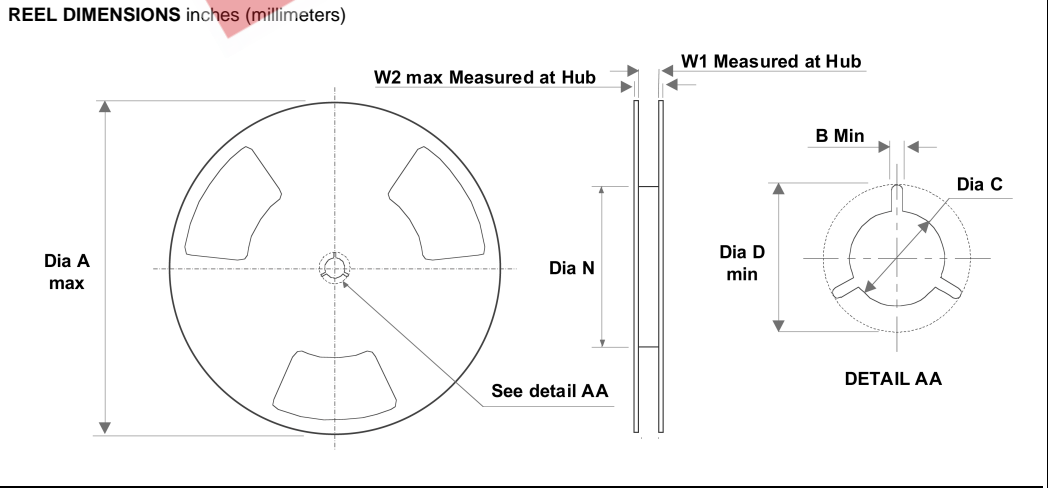
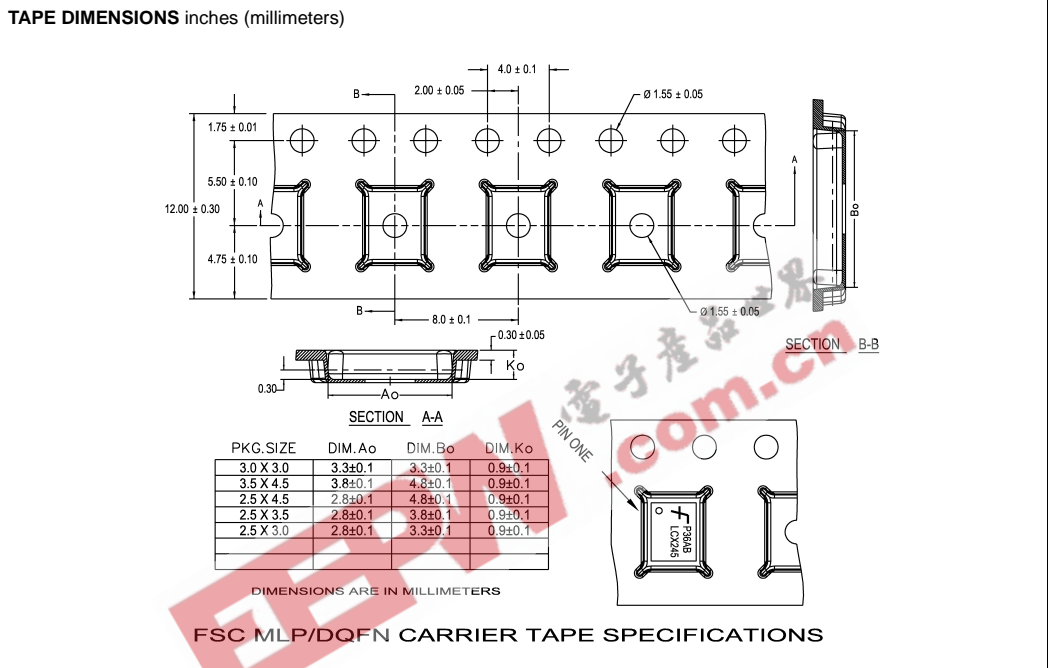

Tape Size	A	B	C	D	N	W1	W2
12 mm	13.0 (330.0)	0.059 (1.50)	0.512 (13.00)	0.795 (20.20)	2.165 (55.00)	0.488 (12.4)	0.724 (18.4)

**Physical Dimensions** inches (millimeters) unless otherwise noted

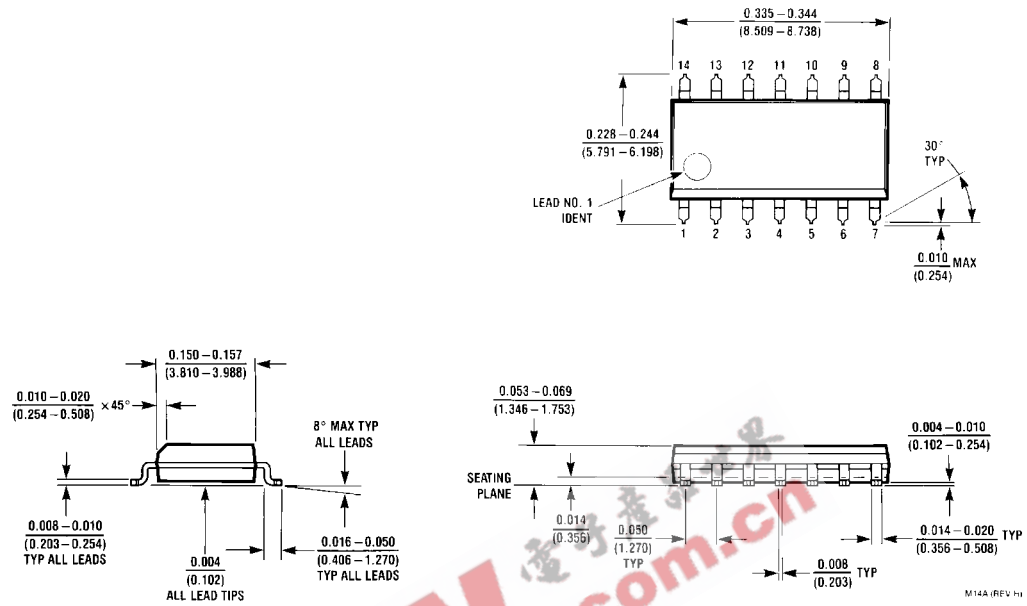

14-Lead Small Outline Integrated Circuit (SOIC), JEDEC MS-012, 0.150" Narrow  
Package Number M14A



**Physical Dimensions** inches (millimeters) unless otherwise noted (Continued)

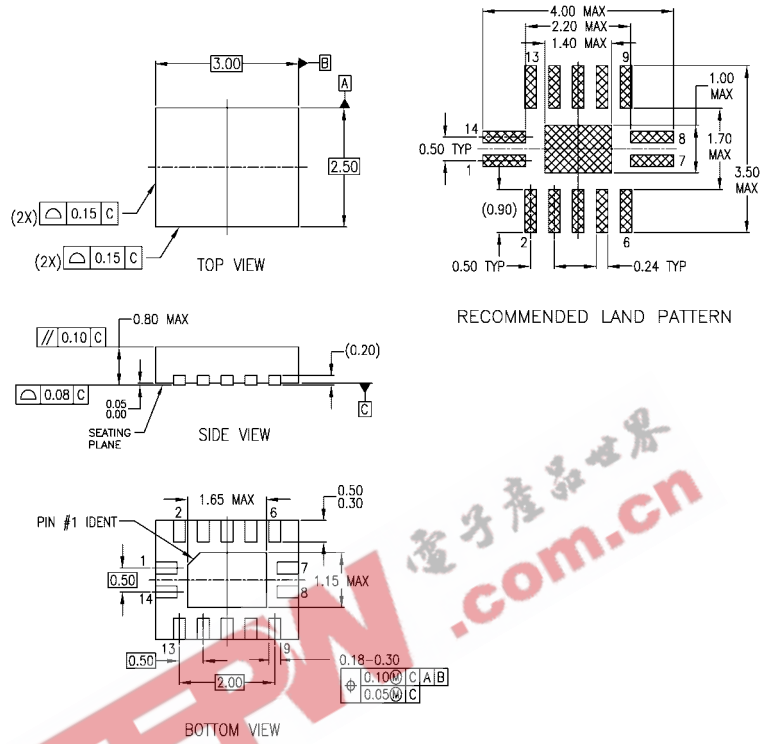

NOTES:

- A. CONFORMS TO JEDEC REGISTRATION MO-241, VARIATION AA
- B. DIMENSIONS ARE IN MILLIMETERS.
- C. DIMENSIONS AND TOLERANCES PER ASME Y14.5M, 1994

MLP014ArevA

**Pb-Free 14-Terminal Depopulated Quad Very-Thin Flat Pack No Leads (DQFN), JEDEC MO-241, 2.5 x 3.0mm Package Number MLP014A**

### Physical Dimensions inches (millimeters) unless otherwise noted (Continued)

**Physical Dimensions** inches (millimeters) unless otherwise noted (Continued)

0.43 TYP  
5.0±0.1 -A-  
14 8  
6.4  
3.2  
4.4±0.1 -B-  
1 7  
ALL LEAD TIPS  
PIN #1 IDENT.

7.72  
4.16  
1.78  
0.65 0.42  
LAND PATTERN RECOMMENDATION

1.2 MAX  
ALL LEAD TIPS  
0.1 C  
0.90±0.15  
0.10±0.05  
0.65  
0.19 - 0.30  
0.13 A B C  
SEE DETAIL A  
0.09-0.20

NOTES:  
A. CONFORMS TO JEDEC REGISTRATION MO-153, VARIATION AB, REF NOTE 6, DATED 7/93  
B. DIMENSIONS ARE IN MILLIMETERS  
C. DIMENSIONS ARE EXCLUSIVE OF BURRS, MOLD FLASH, AND TIE BAR EXTRUSIONS  
D. DIMENSIONING AND TOLERANCES PER ANSI Y14.5M, 1992

MTC14revD

12.00° TOP & BOTTOM  
R0.09 min  
GAGE PLANE  
0.25  
SEATING PLANE  
R0.09 min  
0°-8°  
0.6±0.1  
1.00  
DETAIL A

**14-Lead Thin Shrink Small Outline Package (TSSOP), JEDEC MO-153, 4.4mm Wide Package Number MTC14**

Fairchild does not assume any responsibility for use of any circuitry described, no circuit patent licenses are implied and Fairchild reserves the right at any time without notice to change said circuitry and specifications.

**LIFE SUPPORT POLICY**

FAIRCHILD'S PRODUCTS ARE NOT AUTHORIZED FOR USE AS CRITICAL COMPONENTS IN LIFE SUPPORT DEVICES OR SYSTEMS WITHOUT THE EXPRESS WRITTEN APPROVAL OF THE PRESIDENT OF FAIRCHILD SEMICONDUCTOR CORPORATION. As used herein:

1. Life support devices or systems are devices or systems which, (a) are intended for surgical implant into the body, or (b) support or sustain life, and (c) whose failure to perform when properly used in accordance with instructions for use provided in the labeling, can be reasonably expected to result in a significant injury to the user.
2. A critical component in any component of a life support device or system whose failure to perform can be reasonably expected to cause the failure of the life support device or system, or to affect its safety or effectiveness.

[www.fairchildsemi.com](http://www.fairchildsemi.com)