

DATA SHEET

EEPW 电子产品世界
.com.cn

74ALVT16827

2.5V/3.3V ALVT 20-bit buffer/line driver,
non-inverting (3-State)

Product specification
Supersedes data of 1996 Jun 19
IC23 Data Handbook

1998 Feb 13

2.5V/3.3V 20-bit buffer/line driver, non-inverting (3-State)

74ALVT16827

FEATURES

- Multiple V_{CC} and GND pins minimize switching noise
- 5V I/O Compatible
- Live insertion/extraction permitted
- 3-State output buffers
- Power-up 3-State
- Output capability: +64mA/-32mA
- Latch-up protection exceeds 500mA per Jedec JC40.2 Std 17
- ESD protection exceeds 2000 V per MIL STD 883 Method 3015 and 200 V per Machine Model
- Bus hold data inputs eliminate the need for external pull-up resistors to hold unused inputs

DESCRIPTION

The 74ALVT16827 high-performance BiCMOS device combines low static and dynamic power dissipation with high speed and high output drive. It is designed for V_{CC} operation at 2.5V or 3.3V with I/O compatibility to 5V.

The 74ALVT16827 20-bit buffers provide high performance bus interface buffering for wide data/address paths or buses carrying parity. They have NOR Output Enables ($n\overline{OE}1$, $n\overline{OE}2$) for maximum control flexibility.

QUICK REFERENCE DATA

SYMBOL	PARAMETER	CONDITIONS $T_{amb} = 25^{\circ}\text{C}$	TYPICAL		UNIT
			2.5V	3.3V	
t_{PLH} t_{PHL}	Propagation delay nAx to nBx or nBx to nAx	$C_L = 50\text{pF}$	1.7 1.8	1.3 1.3	ns
C_{IN}	Input capacitance DIR, \overline{OE}	$V_I = 0\text{V}$ or V_{CC}	3	3	pF
C_{Out}	Output capacitance	$V_{I/O} = 0\text{V}$ or V_{CC}	9	9	pF
I_{CCZ}	Total supply current	Outputs disabled	40	70	μA

ORDERING INFORMATION

PACKAGES	TEMPERATURE RANGE	OUTSIDE NORTH AMERICA	NORTH AMERICA	DWG NUMBER
56-Pin Plastic SSOP Type III	-40°C to $+85^{\circ}\text{C}$	74ALVT16827 DL	AV16827 DL	SOT371-1
56-Pin Plastic TSSOP Type II	-40°C to $+85^{\circ}\text{C}$	74ALVT16827 DGG	AV16827 DGG	SOT364-1

PIN DESCRIPTION

PIN NUMBER	SYMBOL	FUNCTION
55, 54, 52, 51, 49, 48, 47, 45, 44, 43, 42, 41, 40, 38, 37, 36, 34, 33, 31, 30	1A0 - 1A9 2A0 - 2A9	Data inputs
2, 3, 5, 6, 8, 9, 10, 12, 13, 14, 15, 16, 17, 19, 20, 21, 23, 24, 26, 27	1Y0 - 1Y9 2Y0 - 2Y9	Data outputs
1, 56, 28, 29	$1\overline{OE}0$, $1\overline{OE}1$ $2\overline{OE}0$, $2\overline{OE}1$	Output enable inputs (active-Low)
4, 11, 18, 25, 32, 39, 46, 53	GND	Ground (0V)
7, 22, 35, 50	V_{CC}	Positive supply voltage

2.5V/3.3V 20-bit buffer/line driver, non-inverting (3-State)

74ALVT16827

PIN CONFIGURATION

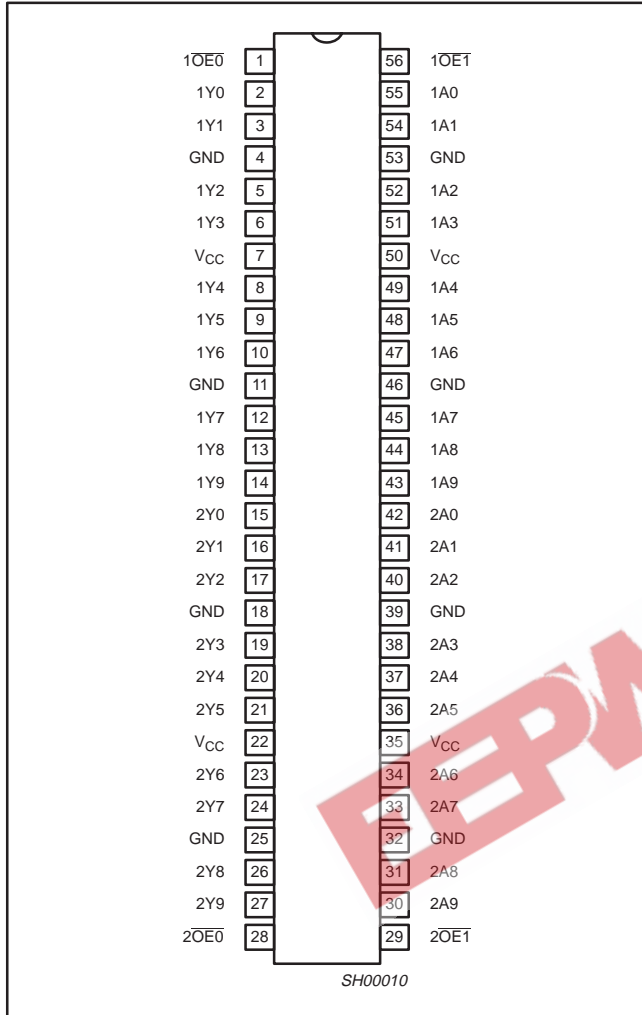

LOGIC SYMBOL (IEEE/IEC)

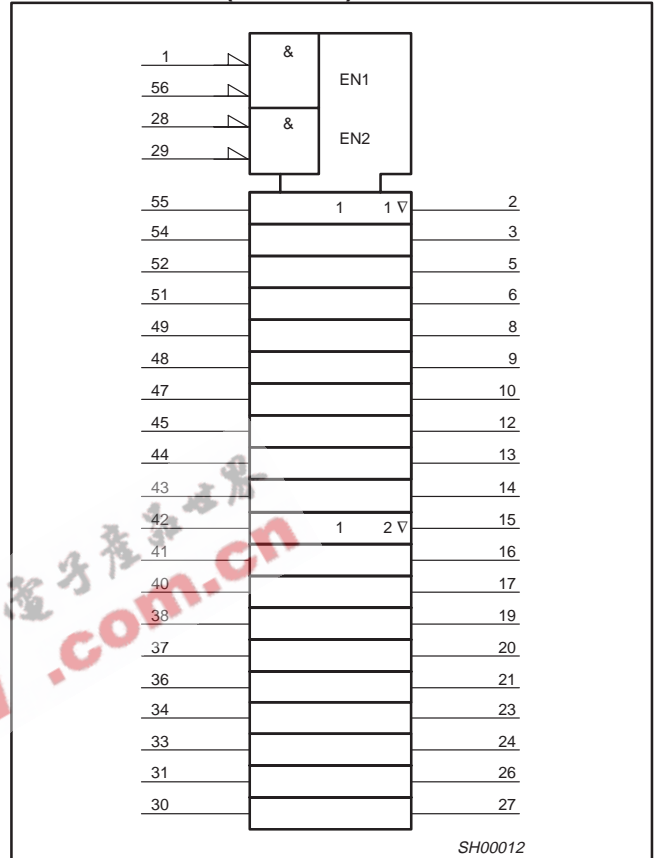

LOGIC SYMBOL

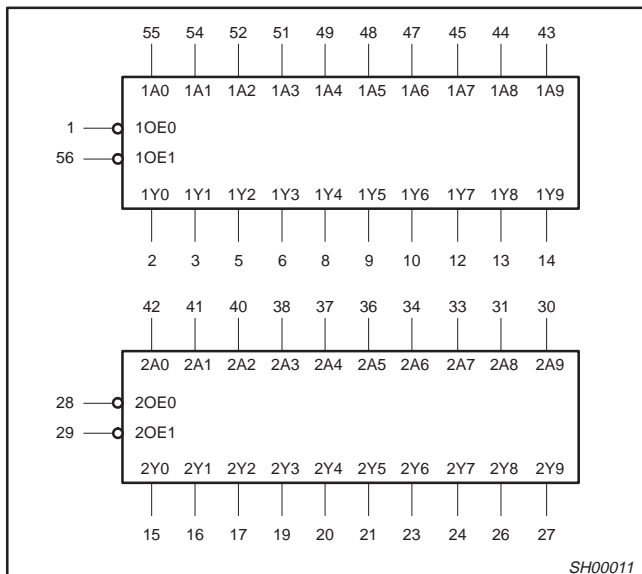

FUNCTION TABLE

INPUTS		OUTPUTS	OPERATING MODE
nOE _x	nA _x	nY _x	
L	L	L	Transparent
L	H	H	Transparent
H	X	Z	High impedance

- X = Don't care
- Z = High impedance "off" state
- H = High voltage level
- L = Low voltage level

2.5V/3.3V 20-bit buffer/line driver, non-inverting (3-State)

74ALVT16827

LOGIC DIAGRAM

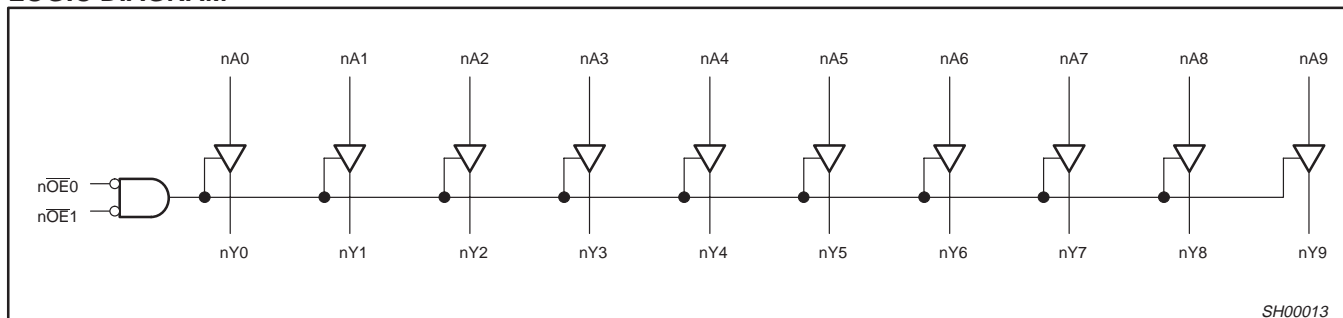

ABSOLUTE MAXIMUM RATINGS^{1, 2}

SYMBOL	PARAMETER	CONDITIONS	RATING	UNIT
V_{CC}	DC supply voltage		-0.5 to +7.0	V
I_{IK}	DC input diode current	$V_I < 0$	-18	mA
V_I	DC input voltage ³		-1.2 to +7.0	V
I_{OK}	DC output diode current	$V_O < 0$	-50	mA
V_{OUT}	DC output voltage ³	output in Off or High state	-0.5 to +5.5	V
I_{OUT}	DC output current	output in Low state	128	mA
T_{stg}	Storage temperature range		-65 to 150	°C

NOTES:

- Stresses beyond those listed may cause permanent damage to the device. These are stress ratings only and functional operation of the device at these or any other conditions beyond those indicated under "recommended operating conditions" is not implied. Exposure to absolute-maximum-rated conditions for extended periods may affect device reliability.
- The performance capability of a high-performance integrated circuit in conjunction with its thermal environment can create junction temperatures which are detrimental to reliability. The maximum junction temperature of this integrated circuit should not exceed 150°C.
- The input and output voltage ratings may be exceeded if the input and output current ratings are observed.

RECOMMENDED OPERATING CONDITIONS

SYMBOL	PARAMETER	2.5V RANGE LIMITS		3.3V RANGE LIMITS		UNIT
		MIN	MAX	MIN	MAX	
V_{CC}	DC supply voltage	2.3	2.7	3.0	3.6	V
V_I	Input voltage	0	5.5	0	5.5	V
V_{IH}	High-level input voltage	1.7		2.0		V
V_{IL}	Input voltage		0.7		0.8	V
I_{OH}	High-level output current		-8		-32	mA
I_{OL}	Low-level output current		8		32	mA
	Low-level output current; current duty cycle $\leq 50\%$; $f \geq 1$ kHz		24		64	
$\Delta t/\Delta v$	Input transition rise or fall rate; Outputs enabled		10		10	ns/V
T_{amb}	Operating free-air temperature range	-40	+85	-40	+85	°C

2.5V/3.3V 20-bit buffer/line driver, non-inverting
(3-State)

74ALVT16827

DC ELECTRICAL CHARACTERISTICS (3.3V ± 0.3V RANGE)

SYMBOL	PARAMETER	TEST CONDITIONS	LIMITS			UNIT
			Temp = -40°C to +85°C			
			MIN	TYP ¹	MAX	
V _{IK}	Input clamp voltage	V _{CC} = 3.0V; I _{IK} = -18mA		-0.85	-1.2	V
V _{OH}	High-level output voltage	V _{CC} = 3.0 to 3.6V; I _{OH} = -100μA	V _{CC} -0.2	V _{CC}		
		V _{CC} = 3.0V; I _{OH} = -32mA	2.0	2.3		
V _{OL}	Low-level output voltage	V _{CC} = 3.0V; I _{OL} = 100μA		0.07	0.2	V
		V _{CC} = 3.0V; I _{OL} = 16mA		0.25	0.4	
		V _{CC} = 3.0V; I _{OL} = 32mA		0.3	0.5	
		V _{CC} = 3.0V; I _{OL} = 64mA		0.4	0.55	
I _I	Input leakage current	V _{CC} = 3.6V; V _I = V _{CC} or GND	Control pins	0.1	±1	μA
		V _{CC} = 0 or 3.6V; V _I = 5.5V		0.1	10	
		V _{CC} = 3.6V; V _I = V _{CC}	Data pins ⁴	0.5	1	
		V _{CC} = 3.6V; V _I = 0V		0.1	-5	
I _{OFF}	Off current	V _{CC} = 0V; V _I or V _O = 0 to 4.5V		0.1	±100	μA
I _{HOLD}	Bus Hold current Data inputs ⁶	V _{CC} = 3V; V _I = 0.8V	75	130		μA
		V _{CC} = 3V; V _I = 2.0V	-75	-140		
		V _{CC} = 0V to 3.6V; V _{CC} = 3.6V	±500			
I _{EX}	Current into an output in the High state when V _O > V _{CC}	V _O = 5.5V; V _{CC} = 3.0V		10	125	μA
I _{PU/PD}	Power up/down 3-State output current ³	V _{CC} ≤ 1.2V; V _O = 0.5V to V _{CC} ; V _I = GND or V _{CC} ; OE/OE = Don't care		1	±100	μA
I _{OZH}	3-State output High current	V _{CC} = 3.6V; V _O = 3.0V; V _I = V _{IL} or V _{IH}		0.5	5	μA
I _{OZL}	3-State output Low current	V _{CC} = 3.6V; V _O = 0.5V; V _I = V _{IL} or V _{IH}		0.5	-5	μA
I _{CCH}	Quiescent supply current	V _{CC} = 3.6V; Outputs High, V _I = GND or V _{CC} , I _O = 0		0.07	0.1	mA
I _{CCL}		V _{CC} = 3.6V; Outputs Low, V _I = GND or V _{CC} , I _O = 0		4.2	6	
I _{CCZ}		V _{CC} = 3.6V; Outputs Disabled; V _I = GND or V _{CC} , I _O = 0 ⁵		0.07	0.1	
ΔI _{CC}	Additional supply current per input pin ²	V _{CC} = 3V to 3.6V; One input at V _{CC} -0.6V, Other inputs at V _{CC} or GND		0.04	0.4	mA

NOTES:

- All typical values are at V_{CC} = 3.3V and T_{amb} = 25°C.
- This is the increase in supply current for each input at the specified voltage level other than V_{CC} or GND
- This parameter is valid for any V_{CC} between 0V and 1.2V with a transition time of up to 10msec. From V_{CC} = 1.2V to V_{CC} = 3.3V ± 0.3V a transition time of 100μsec is permitted. This parameter is valid for T_{amb} = 25°C only.
- Unused pins at V_{CC} or GND.
- I_{CCZ} is measured with outputs pulled up to V_{CC} or pulled down to ground.
- This is the bus hold overdrive current required to force the input to the opposite logic state.

AC CHARACTERISTICS (3.3V ± 0.3V RANGE)

GND = 0V, t_R = t_F = 2.5ns, C_L = 50pF, R_L = 500Ω

SYMBOL	PARAMETER	WAVEFORM	LIMITS			UNIT
			T _{amb} = -40 to +85°C V _{CC} = +3.3V ± 0.3V			
			MIN	TYP	MAX	
t _{PLH} t _{PHL}	Propagation delay nAx to nYx	1	0.5 0.5	1.3 1.3	2.3 2.3	ns
t _{PZH} t _{PZL}	Output enable time to High and Low level	2	1.0 0.5	2.2 1.6	3.8 2.7	ns
t _{PHZ} t _{PLZ}	Output disable time from High and Low level	2	1.0 1.0	3.2 2.5	4.8 3.8	ns

2.5V/3.3V 20-bit buffer/line driver, non-inverting (3-State)

74ALVT16827

DC ELECTRICAL CHARACTERISTICS (2.5V ± 0.2V RANGE)

SYMBOL	PARAMETER	TEST CONDITIONS	LIMITS			UNIT
			Temp = -40°C to +85°C			
			MIN	TYP ¹	MAX	
V _{IK}	Input clamp voltage	V _{CC} = 2.3V; I _{IK} = -18mA		-0.85	-1.2	V
V _{OH}	High-level output voltage	V _{CC} = 2.3 to 2.7V; I _{OH} = -100μA	V _{CC} -0.2	V _{CC}		V
		V _{CC} = 2.3V; I _{OH} = -8mA	1.8	2.1		
V _{OL}	Low-level output voltage	V _{CC} = 2.3V; I _{OL} = 100μA		0.07	0.2	V
		V _{CC} = 2.3V; I _{OL} = 24mA		0.3	0.5	
		V _{CC} = 2.3V; I _{OL} = 8mA			0.47	
I _I	Input leakage current	V _{CC} = 2.7V; V _I = V _{CC} or GND	Control pins	0.1	±1	μA
		V _{CC} = 0 or 2.7V; V _I = 5.5V	Data pins ⁴	0.1	10	
		V _{CC} = 2.7V; V _I = V _{CC}		0.1	1	
		V _{CC} = 2.7V; V _I = 0		0.1	-5	
I _{OFF}	Off current	V _{CC} = 0V; V _I or V _O = 0 to 4.5V		0.1	±100	μA
I _{HOLD}	Bus Hold current	V _{CC} = 2.5V; V _I = 0.8V		115		μA
	Data inputs ⁶	V _{CC} = 2.5V; V _I = 2.0V		-10		μA
I _{EX}	Current into an output in the High state when V _O > V _{CC}	V _O = 5.5V; V _{CC} = 2.3V		10	125	μA
I _{PU/PD}	Power up/down 3-State output current ³	V _{CC} ≤ 1.2V; V _O = 0.5V to V _{CC} ; V _I = GND or V _{CC} OE/OE = Don't care		1	100	μA
I _{OZH}	3-State output High current	V _{CC} = 2.7V; V _O = 2.3V; V _I = V _{IL} or V _{IH}		0.5	5	μA
I _{OZL}	3-State output Low current	V _{CC} = 2.7V; V _O = 0.5V; V _I = V _{IL} or V _{IH}		0.5	-5	μA
I _{CCH}	Quiescent supply current	V _{CC} = 2.7V; Outputs High, V _I = GND or V _{CC} , I _O = 0		0.04	0.1	mA
I _{CCL}		V _{CC} = 2.7V; Outputs Low, V _I = GND or V _{CC} , I _O = 0		3.6	5.0	
I _{CCZ}		V _{CC} = 2.7V; Outputs Disabled; V _I = GND or V _{CC} , I _O = 0 ⁵		0.04	0.1	
ΔI _{CC}	Additional supply current per input pin ²	V _{CC} = 2.3V to 2.7V; One input at V _{CC} -0.6V, Other inputs at V _{CC} or GND		0.04	0.4	mA

NOTES:

- All typical values are at V_{CC} = 2.5V and T_{amb} = 25°C.
- This is the increase in supply current for each input at the specified voltage level other than V_{CC} or GND
- This parameter is valid for any V_{CC} between 0V and 1.2V with a transition time of up to 10msec. From V_{CC} = 1.2V to V_{CC} = 2.5V ± 0.2V a transition time of 100μsec is permitted. This parameter is valid for T_{amb} = 25°C only.
- Unused pins at V_{CC} or GND.
- I_{CCZ} is measured with outputs pulled up to V_{CC} or pulled down to ground.
- Not guaranteed.

AC CHARACTERISTICS (2.5V ± 0.2V RANGE)

GND = 0V, t_R = t_F = 2.5ns, C_L = 50pF, R_L = 500Ω

SYMBOL	PARAMETER	WAVEFORM	LIMITS			UNIT
			T _{amb} = -40 to +85°C V _{CC} = +2.5V ± 0.2V			
			MIN	TYP	MAX	
t _{PLH} t _{PHL}	Propagation delay nAx to nYx	1	0.5 0.5	1.7 1.8	2.9 3.0	ns
t _{PZH} t _{PZL}	Output enable time to High and Low level	2	1.0 1.0	3.1 2.1	5.5 4.1	ns
t _{PHZ} t _{PLZ}	Output disable time from High and Low level	2	1.0 1.0	3.1 2.3	5.1 3.9	ns

2.5V/3.3V 20-bit buffer/line driver, non-inverting (3-State)

74ALVT16827

AC WAVEFORMS

$V_M = 1.5V$ for $V_{CC} \geq 3.0V$; $V_M = V_{CC}/2$ for $V_{CC} \leq 2.7V$
 $V_X = V_{OL} + 0.3V$ for $V_{CC} \geq 3.0V$; $V_X = V_{OL} + 0.15V$ for $V_{CC} \leq 2.7V$
 $V_Y = V_{OH} - 0.3V$ for $V_{CC} \geq 3.0V$; $V_Y = V_{OH} - 0.15V$ for $V_{CC} \leq 2.7V$

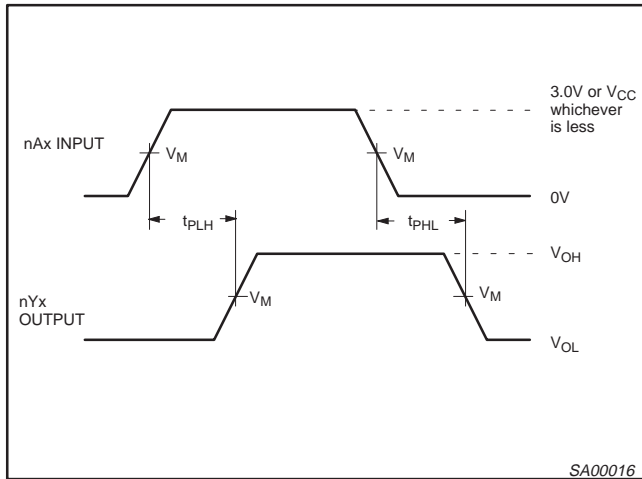

Waveform 1. The Input (nAx) to Output (nYx) Propagation Delays

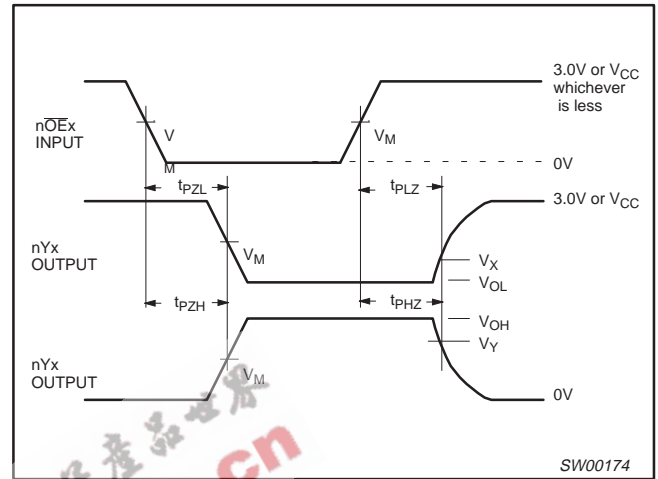

Waveform 2. The 3-State Output Enable and Disable Times

TEST CIRCUIT AND WAVEFORM

Test Circuit for 3-State Outputs

SWITCH POSITION	
TEST	SWITCH
t_{PLZ}/t_{PZL}	6V or $V_{CC} \times 2$
t_{PLH}/t_{PHL}	Open
t_{PHZ}/t_{PZH}	GND

DEFINITIONS

R_L = Load resistor; see AC CHARACTERISTICS for value.

C_L = Load capacitance includes jig and probe capacitance: See AC CHARACTERISTICS for value.

R_T = Termination resistance should be equal to Z_{OUT} of pulse generators.

FAMILY	INPUT PULSE REQUIREMENTS				
	Amplitude	Rep. Rate	t_W	t_R	t_F
74ALVT16	3.0V or V_{CC} whichever is less	$\leq 10\text{MHz}$	500ns	$\leq 2.5\text{ns}$	$\leq 2.5\text{ns}$

SW00205

2.5V/3.3V ALVT 20-bit buffer/line driver, non-inverting
(3-State)

74ALVT16827

SSOP56: plastic shrink small outline package; 56 leads; body width 7.5 mm

SOT371-1

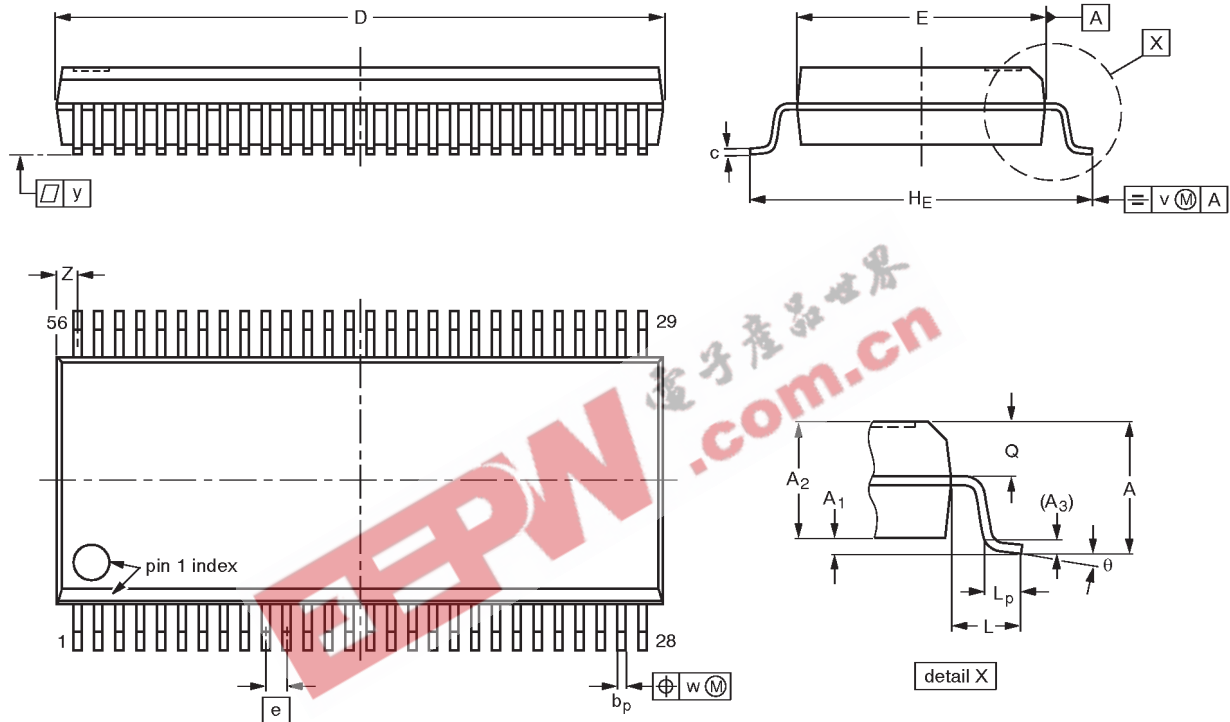

DIMENSIONS (mm are the original dimensions)

UNIT	A max.	A ₁	A ₂	A ₃	b _p	c	D ⁽¹⁾	E ⁽¹⁾	e	H _E	L	L _p	Q	v	w	y	Z ⁽¹⁾	θ
mm	2.8	0.4 0.2	2.35 2.20	0.25	0.3 0.2	0.22 0.13	18.55 18.30	7.6 7.4	0.635	10.4 10.1	1.4	1.0 0.6	1.2 1.0	0.25	0.18	0.1	0.85 0.40	8° 0°

Note

1. Plastic or metal protrusions of 0.25 mm maximum per side are not included.

OUTLINE VERSION	REFERENCES				EUROPEAN PROJECTION	ISSUE DATE
	IEC	JEDEC	EIAJ			
SOT371-1		MO-118AB				93-11-02 95-02-04

2.5V/3.3V ALVT 20-bit buffer/line driver, non-inverting
(3-State)

74ALVT16827

TSSOP56: plastic thin shrink small outline package; 56 leads; body width 6.1mm

SOT364-1

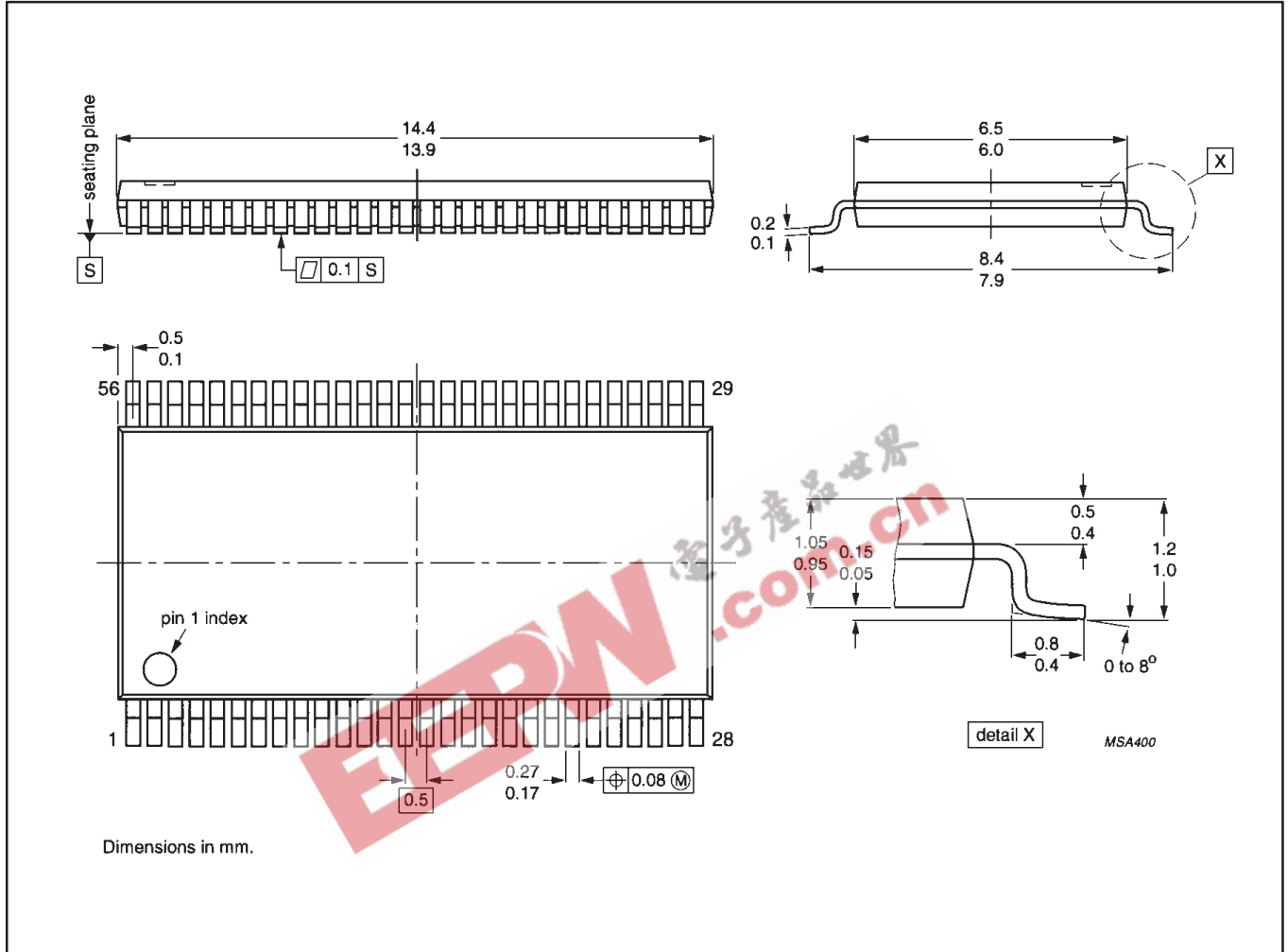

2.5V/3.3V ALVT 20-bit buffer/line driver, non-inverting (3-State)

74ALVT16827

Data sheet status

Data sheet status	Product status	Definition [1]
Objective specification	Development	This data sheet contains the design target or goal specifications for product development. Specification may change in any manner without notice.
Preliminary specification	Qualification	This data sheet contains preliminary data, and supplementary data will be published at a later date. Philips Semiconductors reserves the right to make changes at any time without notice in order to improve design and supply the best possible product.
Product specification	Production	This data sheet contains final specifications. Philips Semiconductors reserves the right to make changes at any time without notice in order to improve design and supply the best possible product.

[1] Please consult the most recently issued datasheet before initiating or completing a design.

Definitions

Short-form specification — The data in a short-form specification is extracted from a full data sheet with the same type number and title. For detailed information see the relevant data sheet or data handbook.

Limiting values definition — Limiting values given are in accordance with the Absolute Maximum Rating System (IEC 134). Stress above one or more of the limiting values may cause permanent damage to the device. These are stress ratings only and operation of the device at these or at any other conditions above those given in the Characteristics sections of the specification is not implied. Exposure to limiting values for extended periods may affect device reliability.

Application information — Applications that are described herein for any of these products are for illustrative purposes only. Philips Semiconductors make no representation or warranty that such applications will be suitable for the specified use without further testing or modification.

Disclaimers

Life support — These products are not designed for use in life support appliances, devices or systems where malfunction of these products can reasonably be expected to result in personal injury. Philips Semiconductors customers using or selling these products for use in such applications do so at their own risk and agree to fully indemnify Philips Semiconductors for any damages resulting from such application.

Right to make changes — Philips Semiconductors reserves the right to make changes, without notice, in the products, including circuits, standard cells, and/or software, described or contained herein in order to improve design and/or performance. Philips Semiconductors assumes no responsibility or liability for the use of any of these products, conveys no license or title under any patent, copyright, or mask work right to these products, and makes no representations or warranties that these products are free from patent, copyright, or mask work right infringement, unless otherwise specified.

Philips Semiconductors
811 East Arques Avenue
P.O. Box 3409
Sunnyvale, California 94088-3409
Telephone 800-234-7381

© Copyright Philips Electronics North America Corporation 1998
All rights reserved. Printed in U.S.A.

print code

Date of release: 05-96

Document order number:

9397-750-03805

Let's make things better.