

DATA SHEET

EEPW 电子产品世界
.com.cn

74ALVC16245/74ALVCH16245 2.5V/3.3V 16-bit bus transceiver with direction pin (3-State)

Product specification
Supersedes data of 1998 Jun 16
IC24 Data Handbook

1998 Jun 29

16-bit bus transceiver with direction pin (3-State)

74ALVC16245/
74ALVCH16245

FEATURES

- Wide supply voltage range of 1.2V to 3.6V
- Complies with JEDEC standard no. 8-1A
- CMOS low power consumption
- MULTIBYTE™ flow-through standard pin-out architecture
- Low inductance multiple V_{CC} and ground pins for minimum noise and ground bounce
- Direct interface with TTL levels
- All data inputs have bus hold (74ALVCH16245 only)
- Output drive capability 50 Ω transmission lines @ 85°C
- Current drive ± 24 mA at 3.0 V

DESCRIPTION

The 74ALVC16245(74ALVCH16245) is a 16-bit transceiver featuring non-inverting 3-State bus compatible outputs in both send and receive directions.

The 74ALVC16245(74ALVCH16245) features two output enable ($n\overline{OE}$) inputs for easy cascading and two send/receive ($n\overline{DIR}$) inputs for direction control. $n\overline{OE}$ controls the outputs so that the buses are effectively isolated. This device can be used as two 8-bit transceivers or one 16-bit transceiver.

The 74ALVCH16245 has active bus hold circuitry which is provided to hold unused or floating data inputs at a valid logic level. This feature eliminates the need for external pull-up or pull-down resistors.

The 74ALVC16245 has 5V tolerant inputs.

PIN CONFIGURATION

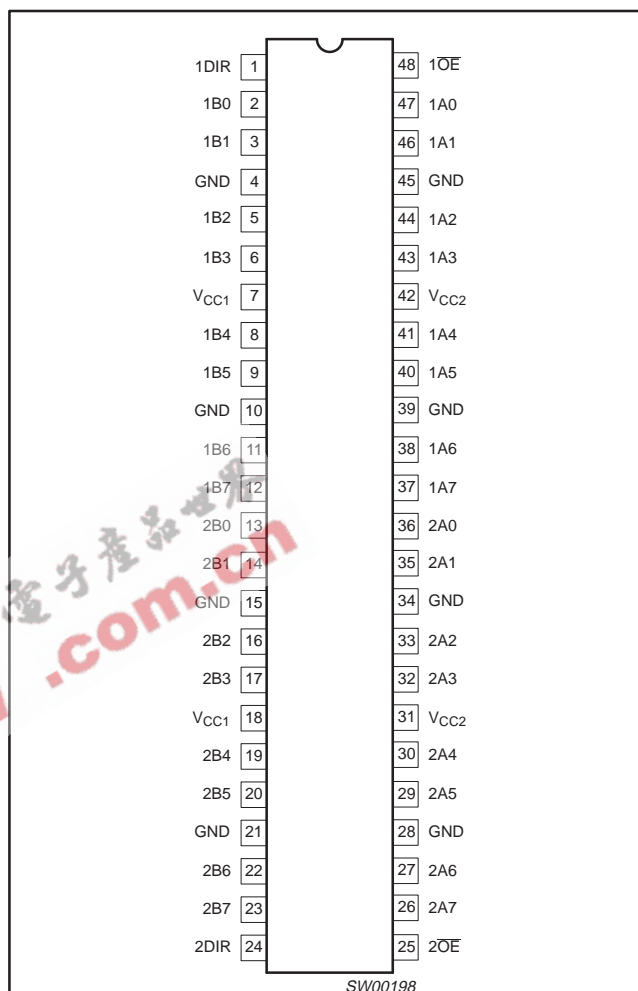

QUICK REFERENCE DATA

$GND = 0V$; $T_{amb} = 25^{\circ}C$; $t_r = t_f \leq 2.5ns$

SYMBOL	PARAMETER	CONDITIONS	TYPICAL	UNIT	
t_{PHL}/t_{PLH}	Propagation delay An to Bn; Bn to An	$V_{CC} = 2.5V$, $C_L = 30pF$ $V_{CC} = 3.3V$, $C_L = 50pF$	1.9	ns	
C_I	Input capacitance		4.0	pF	
$C_{I/O}$	Input/output capacitance		8.0	pF	
C_{PD}	Power dissipation capacitance per buffer	$V_I = GND$ to V_{CC}^1	Outputs enabled	29	pF
			Outputs disabled	5	

NOTE:

- C_{PD} is used to determine the dynamic power dissipation (P_D in μW):
 $P_D = C_{PD} \times V_{CC}^2 \times f_i + \sum (C_L \times V_{CC}^2 \times f_o)$ where: f_i = input frequency in MHz; C_L = output load capacitance in pF;
 f_o = output frequency in MHz; V_{CC} = supply voltage in V; $\sum (C_L \times V_{CC}^2 \times f_o)$ = sum of the outputs.

ORDERING INFORMATION

PACKAGES	TEMPERATURE RANGE	OUTSIDE NORTH AMERICA	NORTH AMERICA	DWG NUMBER
48-Pin Plastic SSOP Type III	-40°C to +85°C	74ALVC16245 DL	AC16245 DL	SOT370-1
48-Pin Plastic TSSOP Type II	-40°C to +85°C	74ALVC16245 DGG	AC16245 DGG	SOT362-1
48-Pin Plastic SSOP Type III	-40°C to +85°C	74ALVCH16245 DL	ACH16245 DL	SOT370-1
48-Pin Plastic TSSOP Type II	-40°C to +85°C	74ALVCH16245 DGG	ACH16245 DGG	SOT362-1

16-bit bus transceiver with direction pin (3-State)

74ALVC16245/
74ALVCH16245

PIN DESCRIPTION

PIN NUMBER	SYMBOL	NAME AND FUNCTION
1	1DIR	Direction control
2, 3, 5, 6, 8, 9, 11, 12	1B0 to 1B7	Data inputs/outputs
4, 10, 15, 21, 28, 34, 39, 45	GND	Ground (0V)
7, 18, 31, 42	V _{CC}	Positive supply voltage
13, 14, 16, 17, 19, 20, 22, 23	2B0 to 2B7	Data inputs/outputs
24	2DIR	Direction control
25	2OE	Output enable input (active LOW)
36, 35, 33, 32, 30, 29, 27, 26	2A0 to 2A7	Data inputs/outputs
47, 46, 44, 43, 41, 40, 38, 37	1A0 to 1A7	Data inputs/outputs
48	1OE	Output enable input (active LOW)

LOGIC SYMBOL

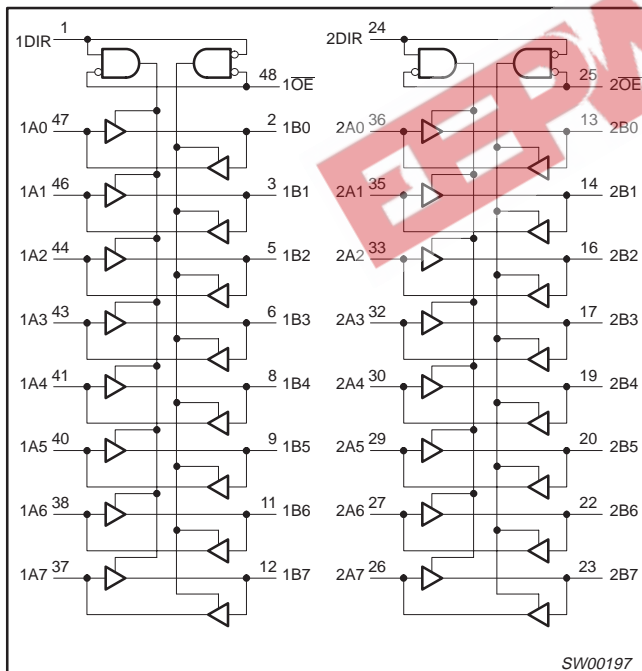

LOGIC SYMBOL (IEEE/IEC)

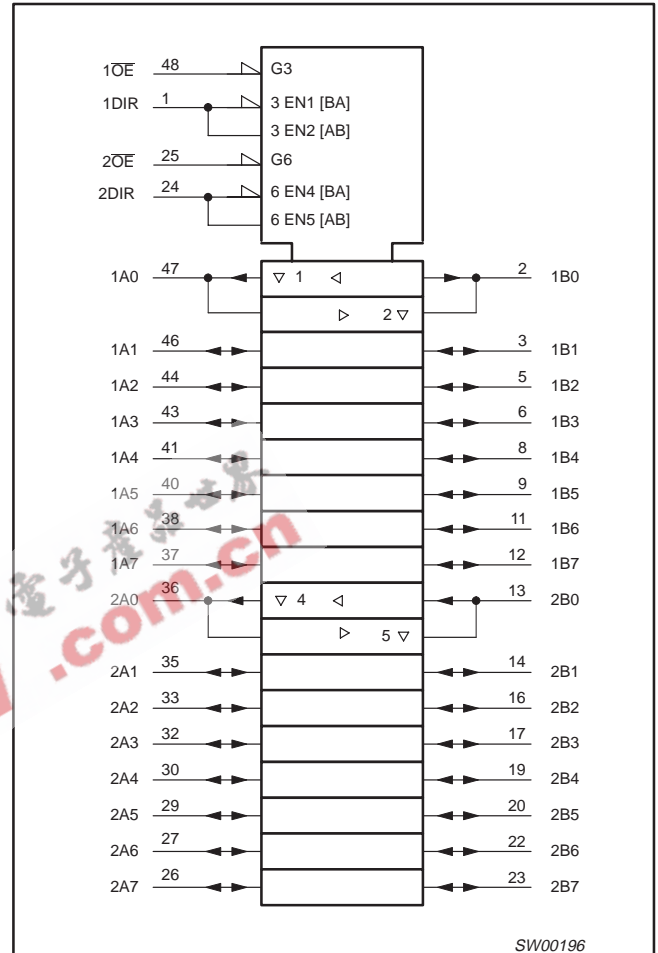

FUNCTION TABLE

INPUTS		INPUTS/OUTPUT	
nOE	nDIR	nAn	nBn
L	L	A = B	inputs
L	H	inputs	B = A
H	X	Z	Z

H = HIGH voltage level
L = LOW voltage level
X = don't care
Z = high impedance OFF-state

BUS HOLD CIRCUIT

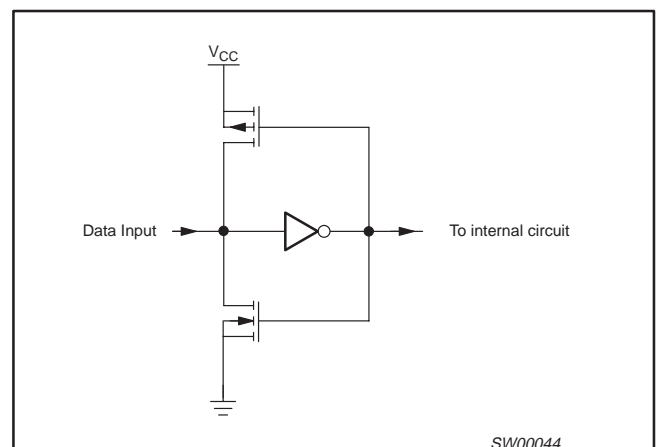

16-bit bus transceiver with direction pin (3-State)

74ALVC16245/
74ALVCH16245

RECOMMENDED OPERATING CONDITIONS

SYMBOL	PARAMETER	CONDITIONS	LIMITS		UNIT
			MIN	MAX	
V_{CC}	DC supply voltage 2.5V range (for max. speed performance @ 30 pF output load)		2.3	2.7	V
	DC supply voltage 3.3V range (for max. speed performance @ 50 pF output load)		3.0	3.6	
	DC supply voltage (for low-voltage applications)		1.2	3.6	
V_I	DC Input voltage range		0	V_{CC}	V
V_O	DC output voltage range		0	V_{CC}	V
T_{amb}	Operating free-air temperature range		-40	+85	°C
t_r, t_f	Input rise and fall times	$V_{CC} = 2.3$ to 3.0V $V_{CC} = 3.0$ to 3.6V	0 0	20 10	ns/V

ABSOLUTE MAXIMUM RATINGS

In accordance with the Absolute Maximum Rating System (IEC 134)

Voltages are referenced to GND (ground = 0V)

SYMBOL	PARAMETER	CONDITIONS	RATING	UNIT
V_{CC}	DC supply voltage		-0.5 to +4.6	V
I_{IK}	DC input diode current	$V_I < 0$	-50	mA
V_I	DC input voltage	For data inputs with bus hold ¹	-0.5 to $V_{CC} + 0.5$	V
		For data inputs without bus hold ¹	-0.5 to +4.6	
		For control pins ¹	-0.5 to +4.6	
I_{OK}	DC output diode current	$V_O > V_{CC}$ or $V_O < 0$	±50	mA
V_O	DC output voltage	Note 1	-0.5 to $V_{CC} + 0.5$	V
I_O	DC output source or sink current	$V_O = 0$ to V_{CC}	±50	mA
I_{GND}, I_{CC}	DC V_{CC} or GND current		±100	mA
T_{stg}	Storage temperature range		-65 to +150	°C
P_{TOT}	Power dissipation per package -plastic medium-shrink (SSOP) -plastic thin-medium-shrink (TSSOP)	For temperature range: -40 to +125 °C	850	mW
		above +55°C derate linearly with 11.3 mW/K above +55°C derate linearly with 8 mW/K	600	

NOTE:

1. The input and output voltage ratings may be exceeded if the input and output current ratings are observed.

16-bit bus transceiver with direction pin (3-State)

74ALVC16245/
74ALVCH16245**DC CHARACTERISTICS**

Over recommended operating conditions. Voltage are referenced to GND (ground = 0 V).

SYMBOL	PARAMETER	TEST CONDITIONS	LIMITS			UNIT
			Temp = -40°C to +85°C			
			MIN	TYP ¹	MAX	
V _{IH}	HIGH level Input voltage	V _{CC} = 2.3 to 2.7V	1.7	1.2		V
		V _{CC} = 2.7 to 3.6V	2.0	1.5		
V _{IL}	LOW level Input voltage	V _{CC} = 2.3 to 2.7V		1.2	0.7	V
		V _{CC} = 2.7 to 3.6V		1.5	0.8	
V _{OH}	HIGH level output voltage	V _{CC} = 2.3 to 3.6V; V _I = V _{IH} or V _{IL} ; I _O = -100μA	V _{CC} -0.2	V _{CC}		V
		V _{CC} = 2.3V; V _I = V _{IH} or V _{IL} ; I _O = -6mA	V _{CC} -0.3	V _{CC} -0.08		
		V _{CC} = 2.3V; V _I = V _{IH} or V _{IL} ; I _O = -12mA	V _{CC} -0.6	V _{CC} -0.26		
		V _{CC} = 2.7V; V _I = V _{IH} or V _{IL} ; I _O = -12mA	V _{CC} -0.5	V _{CC} -0.14		
		V _{CC} = 3.0V; V _I = V _{IH} or V _{IL} ; I _O = -12mA	V _{CC} -0.6	V _{CC} -0.09		
		V _{CC} = 3.0V; V _I = V _{IH} or V _{IL} ; I _O = -24mA	V _{CC} -1.0	V _{CC} -0.28		
V _{OL}	LOW level output voltage	V _{CC} = 2.3 to 3.6V; V _I = V _{IH} or V _{IL} ; I _O = 100μA		GND	0.20	V
		V _{CC} = 2.3V; V _I = V _{IH} or V _{IL} ; I _O = 6mA		0.07	0.40	
		V _{CC} = 2.3V; V _I = V _{IH} or V _{IL} ; I _O = 12mA		0.15	0.70	
		V _{CC} = 2.7V; V _I = V _{IH} or V _{IL} ; I _O = 12mA		0.14	0.40	
		V _{CC} = 3.0V; V _I = V _{IH} or V _{IL} ; I _O = 24mA		0.27	0.55	
I _I	Input leakage current	V _{CC} = 2.3 to 3.6V; V _I = V _{CC} or GND		0.1	5	μA
I _{OZ}	3-State output OFF-state current	V _{CC} = 2.3 to 3.6V; V _I = V _{IH} or V _{IL} ; V _O = V _{CC} or GND		0.1	10	μA
I _{CC}	Quiescent supply current	V _{CC} = 2.3 to 3.6V; V _I = V _{CC} or GND; I _O = 0		0.2	40	μA
ΔI _{CC}	Additional quiescent supply current given per data I/O pin with bus hold	V _{CC} = 2.3V to 3.6V; V _I = V _{CC} - 0.6V; I _O = 0		150	750	μA
I _{BHL} ²	Bus hold LOW sustaining current	V _{CC} = 2.3V; V _I = 0.7V	45	-		μA
		V _{CC} = 3.0V; V _I = 0.8V	75	150		
I _{BHH} ²	Bus hold HIGH sustaining current	V _{CC} = 2.3V; V _I = 1.7V	-45			μA
		V _{CC} = 3.0V; V _I = 2.0V	-75	-175		
I _{BHLO} ²	Bus hold LOW overdrive current	V _{CC} = 3.6V	500			μA
I _{BHHO} ²	Bus hold HIGH overdrive current	V _{CC} = 3.6V	-500			μA

NOTES:

- All typical values are at T_{amb} = 25°C.
- Valid for data inputs of bus hold parts.

AC CHARACTERISTICS FOR V_{CC} = 2.3V TO 2.7V RANGEGND = 0V; t_r = t_f ≤ 2.0ns; C_L = 30pF

SYMBOL	PARAMETER	WAVEFORM	LIMITS			UNIT
			V _{CC} = 2.3 to 2.7V			
			MIN	TYP ¹	MAX	
t _{PHL} /t _{PLH}	Propagation delay nAn to nBn; nBn to nAn	1, 3	1.0	2.0	3.7	ns
t _{PZH} /t _{PZL}	3-State output enable time nOE to nAn; nOE to nBn	2, 3	1.0	2.7	5.7	ns
t _{PHZ} /t _{PLZ}	3-State output disable time nOE to nAn; nOE to nBn	2, 3	1.0	2.2	5.2	ns

NOTES:

- All typical values are measured at T_{amb} = 25°C and V_{CC} = 2.5V.

16-bit bus transceiver with direction pin (3-State)

74ALVC16245/
74ALVCH16245

AC CHARACTERISTICS FOR $V_{CC} = 3.0V$ TO $3.6V$ RANGE AND $V_{CC} = 2.7V$

$GND = 0V$; $t_r = t_f \leq 2.5ns$; $C_L = 50pF$

SYMBOL	PARAMETER	WAVEFORM	LIMITS						UNIT
			$V_{CC} = 3.3 \pm 0.3V$			$V_{CC} = 2.7V$			
			MIN	TYP ^{1, 2}	MAX	MIN	TYP ¹	MAX	
t_{PHL}/t_{PLH}	Propagation delay nAn to nBn; nBn to nAn	1, 3	1.0	1.9	3.0	1.0	2.1	3.6	ns
t_{PZH}/t_{PZL}	3-State output enable time nOE to nAn; nOE to nBn	2, 3	1.0	2.3	4.4	1.0	3.0	5.4	ns
t_{PHZ}/t_{PLZ}	3-State output disable time nOE to nAn; nOE to nBn	2, 3	1.0	2.8	4.1	1.0	3.1	4.6	ns

NOTES:

- All typical values are measured at $T_{amb} = 25^\circ C$.
- Typical value is measured at $V_{CC} = 3.3V$

AC WAVEFORMS FOR $V_{CC} = 2.3V$ TO $2.7V$ AND $V_{CC} < 2.3V$ RANGE

$V_M = 0.5 V_{CC}$
 $V_X = V_{OL} + 0.15V$
 $V_Y = V_{OH} - 0.15V$
 V_{OL} and V_{OH} are the typical output voltage drop that occur with the output load.
 $V_I = V_{CC}$

AC WAVEFORMS FOR $V_{CC} = 3.0V$ TO $3.6V$ AND $V_{CC} = 2.7V$ RANGE

$V_M = 1.5 V$
 $V_X = V_{OL} + 0.3V$
 $V_Y = V_{OH} - 0.3V$
 V_{OL} and V_{OH} are the typical output voltage drop that occur with the output load.
 $V_I = 2.7V$

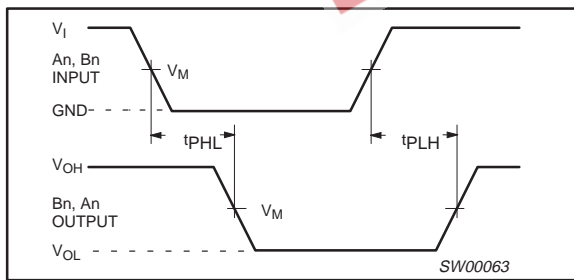

Waveform 1. Input (nAn, nBn) to output (nBn, nAn) propagation delay times

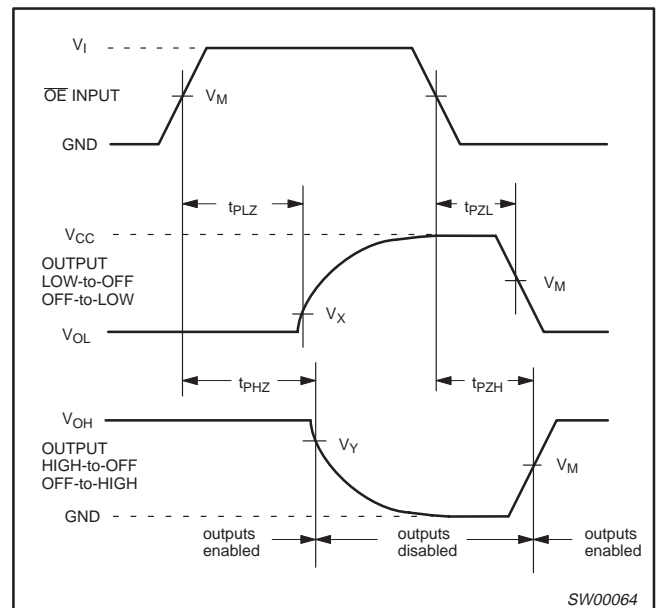

Waveform 2. 3-State enable and disable times

16-bit bus transceiver with direction pin (3-State)

74ALVC16245/
74ALVCH16245

TEST CIRCUIT

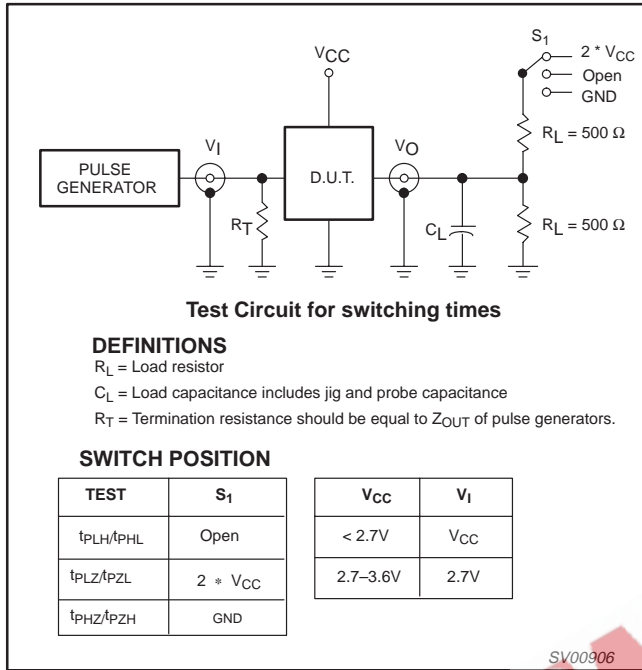

Waveform 3. Load circuitry for switching times

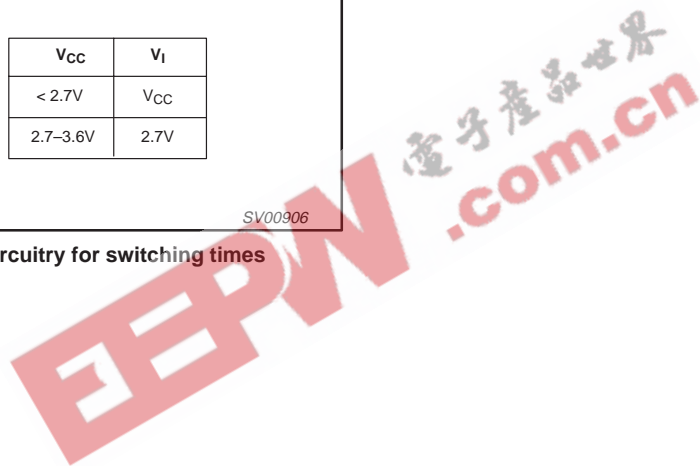

2.5V/3.3V 16-bit bus transceiver with direction pin
(3-State)

74ALVC16245/
74ALVCH16245

SSOP48: plastic shrink small outline package; 48 leads; body width 7.5 mm

SOT370-1

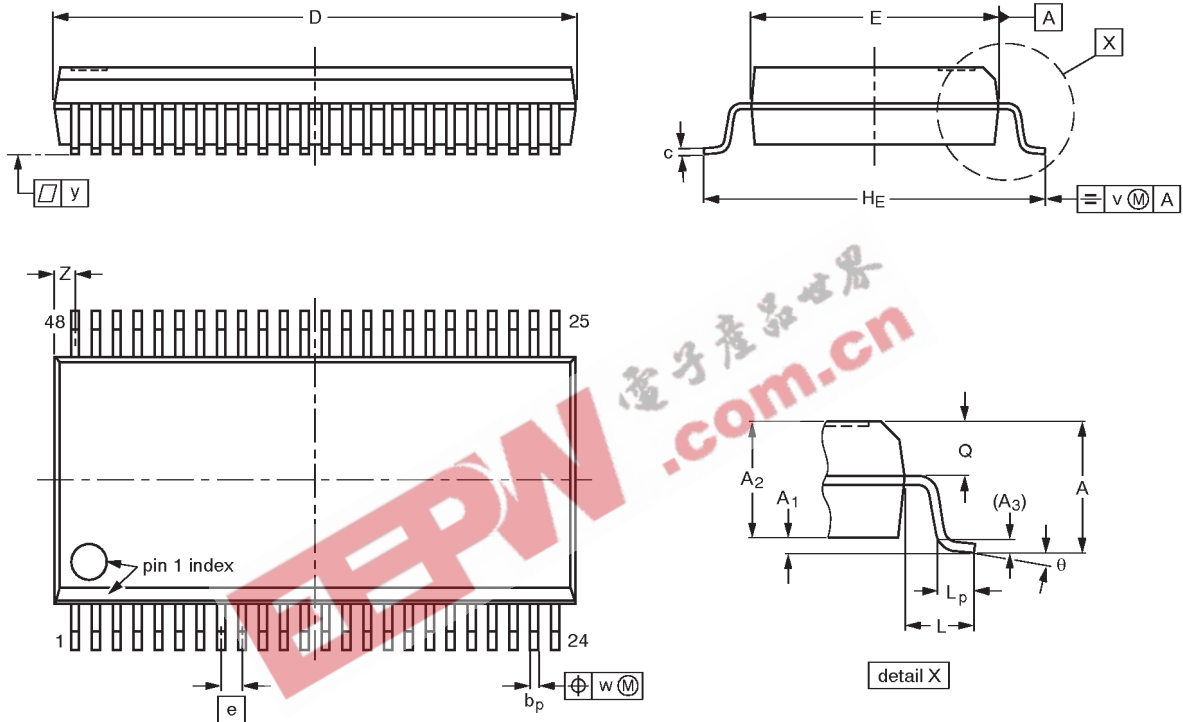

DIMENSIONS (mm are the original dimensions)

UNIT	A max.	A ₁	A ₂	A ₃	b _p	c	D ⁽¹⁾	E ⁽¹⁾	e	H _E	L	L _p	Q	v	w	y	z ⁽¹⁾	θ
mm	2.8	0.4 0.2	2.35 2.20	0.25	0.3 0.2	0.22 0.13	16.00 15.75	7.6 7.4	0.635	10.4 10.1	1.4	1.0 0.6	1.2 1.0	0.25	0.18	0.1	0.85 0.40	8° 0°

Note

1. Plastic or metal protrusions of 0.25 mm maximum per side are not included.

OUTLINE VERSION	REFERENCES				EUROPEAN PROJECTION	ISSUE DATE
	IEC	JEDEC	EIAJ			
SOT370-1		MO-118AA				93-11-02 95-02-04

2.5V/3.3V 16-bit bus transceiver with direction pin
(3-State)

74ALVC16245/
74ALVCH16245

TSSOP48: plastic thin shrink small outline package; 48 leads; body width 6.1mm

SOT362-1

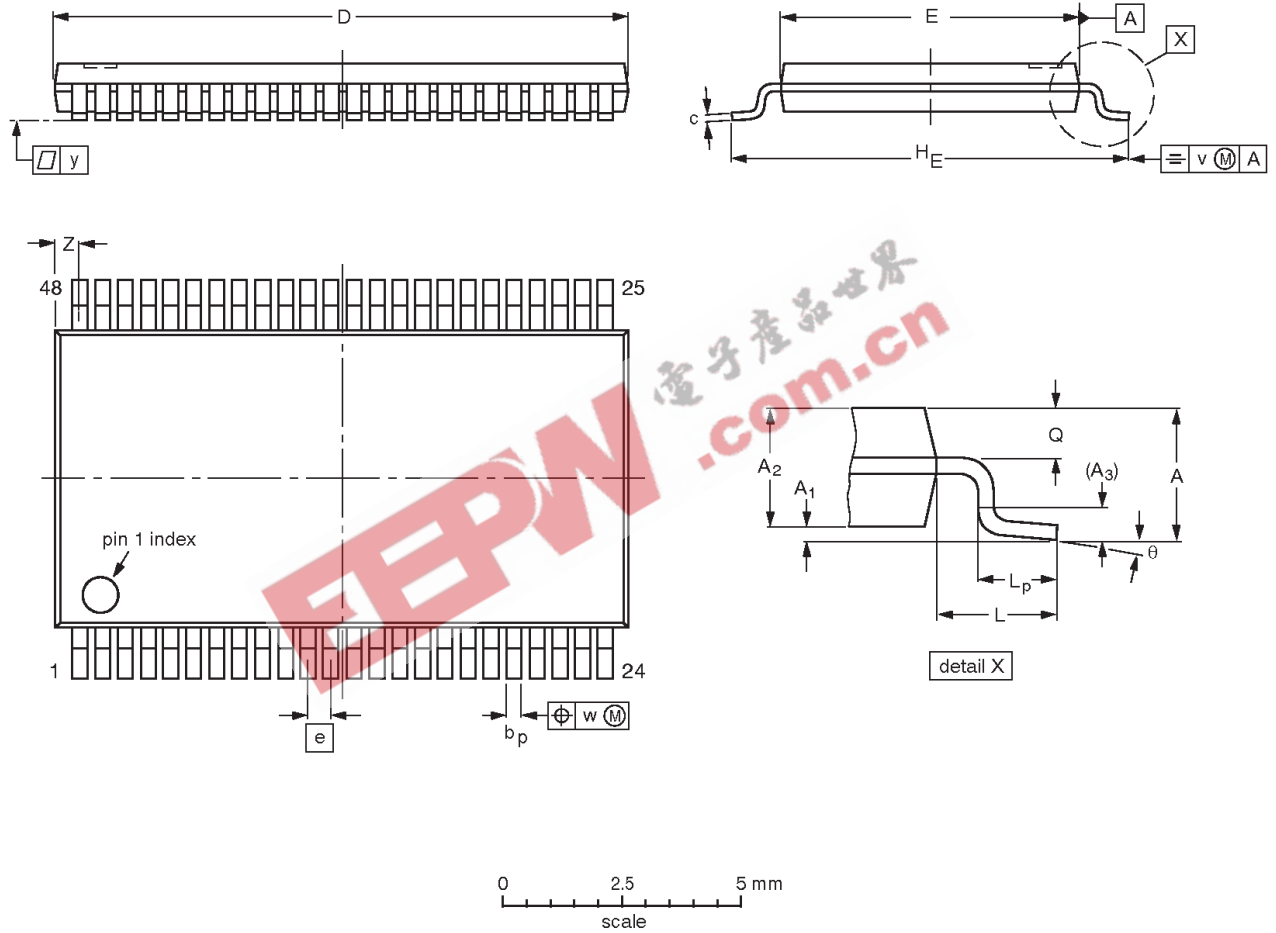

DIMENSIONS (mm are the original dimensions).

UNIT	A max.	A ₁	A ₂	A ₃	b _p	c	D ⁽¹⁾	E ⁽²⁾	e	H _E	L	L _p	Q	v	w	y	Z	θ
mm	1.2	0.15 0.05	1.05 0.85	0.25	0.28 0.17	0.2 0.1	12.6 12.4	6.2 6.0	0.5	8.3 7.9	1	0.8 0.4	0.50 0.35	0.25	0.08	0.1	0.8 0.4	8° 0°

Notes

1. Plastic or metal protrusions of 0.15 mm maximum per side are not included.
2. Plastic interlead protrusions of 0.25 mm maximum per side are not included.

OUTLINE VERSION	REFERENCES				EUROPEAN PROJECTION	ISSUE DATE
	IEC	JEDEC	EIAJ			
SOT362-1		MO-153ED				93-02-03 95-02-10

2.5V/3.3V 16-bit bus transceiver with direction pin
(3-State)

74ALVC16245/
74ALVCH16245

DEFINITIONS

Data Sheet Identification	Product Status	Definition
<i>Objective Specification</i>	Formative or in Design	This data sheet contains the design target or goal specifications for product development. Specifications may change in any manner without notice.
<i>Preliminary Specification</i>	Preproduction Product	This data sheet contains preliminary data, and supplementary data will be published at a later date. Philips Semiconductors reserves the right to make changes at any time without notice in order to improve design and supply the best possible product.
<i>Product Specification</i>	Full Production	This data sheet contains Final Specifications. Philips Semiconductors reserves the right to make changes at any time without notice, in order to improve design and supply the best possible product.

Philips Semiconductors and Philips Electronics North America Corporation reserve the right to make changes, without notice, in the products, including circuits, standard cells, and/or software, described or contained herein in order to improve design and/or performance. Philips Semiconductors assumes no responsibility or liability for the use of any of these products, conveys no license or title under any patent, copyright, or mask work right to these products, and makes no representations or warranties that these products are free from patent, copyright, or mask work right infringement, unless otherwise specified. Applications that are described herein for any of these products are for illustrative purposes only. Philips Semiconductors makes no representation or warranty that such applications will be suitable for the specified use without further testing or modification.

LIFE SUPPORT APPLICATIONS

Philips Semiconductors and Philips Electronics North America Corporation Products are not designed for use in life support appliances, devices, or systems where malfunction of a Philips Semiconductors and Philips Electronics North America Corporation Product can reasonably be expected to result in a personal injury. Philips Semiconductors and Philips Electronics North America Corporation customers using or selling Philips Semiconductors and Philips Electronics North America Corporation Products for use in such applications do so at their own risk and agree to fully indemnify Philips Semiconductors and Philips Electronics North America Corporation for any damages resulting from such improper use or sale.

Philips Semiconductors
811 East Arques Avenue
P.O. Box 3409
Sunnyvale, California 94088-3409
Telephone 800-234-7381

© Copyright Philips Electronics North America Corporation 1998
All rights reserved. Printed in U.S.A.

Date of release: 06-98

Document order number:

9397-750-04538

Let's make things better.