

54LS155/DM54LS155/DM74LS155, 54LS156/DM54LS156/DM74LS156 Dual 2-Line to 4-Line Decoders/Demultiplexers

General Description

These TTL circuits feature dual 1-line-to-4-line demultiplexers with individual strobes and common binary-address inputs in a single 16-pin package. When both sections are enabled by the strobes, the common address inputs sequentially select and route associated input data to the appropriate output of each section. The individual strobes permit activating or inhibiting each of the 4-bit sections as desired. Data applied to input C1 is inverted at its outputs and data applied at C2 is true through its outputs. The inverter following the C1 data input permits use as a 3-to-8-line decoder, or 1-to-8-line demultiplexer, without external gating. Input clamping diodes are provided on these circuits to minimize transmission-line effects and simplify system design.

Features

- Applications:
 - Dual 2-to-4-line decoder
 - Dual 1-to-4-line demultiplexer
 - 3-to-8-line decoder
 - 1-to-8-line demultiplexer
- Individual strobes simplify cascading for decoding or demultiplexing larger words
- Input clamping diodes simplify system design
- Choice of outputs:
 - Totem-pole (LS155)
 - Open-collector (LS156)
- Alternate Military/Aerospace device (54LS155/156) is available. Contact a National Semiconductor Sales Office/Distributor for specifications.

Connection Diagram and Function Tables

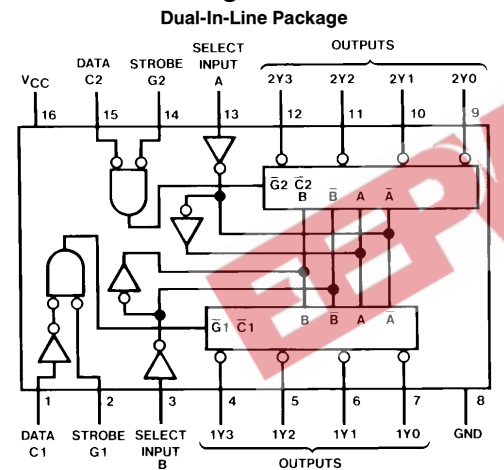

Order Number 54LS155DMQB, 54LS155FMQB, 54LS155LMQB, DM54LS155J, DM54LS155W, DM74LS155M, DM74LS155N, 54LS156DMQB, 54LS156FMQB, DM54LS156J, DM54LS156W, DM74LS156M or DM74LS156N
See NS Package Number E20A, J16A, M16A, N16E or W16A

2-Line-to-4-Line Decoder or
1-Line-to-4-Line Demultiplexer

Inputs				Outputs			
Select	Strobe	Data		1Y0	1Y1	1Y2	1Y3
B	A	G1	C1				
X	X	H	X	H	H	H	H
L	L	L	H	L	H	H	H
L	H	L	H	H	L	H	H
H	L	L	H	H	H	L	H
H	H	L	H	H	H	H	L
X	X	X	L	H	H	H	H

3-Line-to-8-Line Decoder or
1-Line-to-8-Line Demultiplexer

Inputs				Outputs							
Select	Strobe Or Data			(0)	(1)	(2)	(3)	(4)	(5)	(6)	(7)
C†	B	A	G‡	2Y0	2Y1	2Y2	2Y3	1Y0	1Y1	1Y2	1Y3
X	X	X	H	H	H	H	H	H	H	H	H
L	L	L	L	L	H	H	H	H	H	H	H
L	L	H	L	H	L	H	H	H	H	H	H
L	H	L	L	H	H	L	H	H	H	H	H
L	H	H	L	H	H	H	L	H	H	H	H
H	L	L	L	H	H	H	H	L	H	H	H
H	L	H	L	H	H	H	H	L	L	H	H
H	H	L	L	H	H	H	H	H	H	L	H
H	H	H	L	H	H	H	H	H	H	H	L

Inputs				Outputs			
Select	Strobe	Data		2Y0	2Y1	2Y2	2Y3
B	A	G2	C2				
X	X	H	X	H	H	H	H
L	L	L	L	L	H	H	H
L	H	L	L	L	H	L	H
H	L	L	L	L	H	H	L
H	H	L	L	L	H	H	L
X	X	X	H	H	H	H	H

†C = inputs C1 and C2 connected together
‡G = inputs G1 and G2 connected together
H = high level, L = low level, X = don't care

54LS155/DM54LS155/DM74LS155,
54LS156/DM54LS156/DM74LS156 Dual 2-Line to 4-Line Decoders/Demultiplexers

Absolute Maximum Ratings (Note)

If Military/Aerospace specified devices are required, please contact the National Semiconductor Sales Office/Distributors for availability and specifications.

Supply Voltage	7V
Input Voltage	7V
Operating Free Air Temperature Range	
DM54LS and 54LS	−55°C to +125°C
DM74LS	0°C to +70°C
Storage Temperature Range	−65°C to +150°C

Note: The "Absolute Maximum Ratings" are those values beyond which the safety of the device cannot be guaranteed. The device should not be operated at these limits. The parametric values defined in the "Electrical Characteristics" table are not guaranteed at the absolute maximum ratings. The "Recommended Operating Conditions" table will define the conditions for actual device operation.

Recommended Operating Conditions

Symbol	Parameter	DM54LS155			DM74LS155			Units
		Min	Nom	Max	Min	Nom	Max	
V _{CC}	Supply Voltage	4.5	5	5.5	4.75	5	5.25	V
V _{IH}	High Level Input Voltage	2			2			V
V _{IL}	Low Level Input Voltage			0.7			0.8	V
V _{OH}	High Level Output Current			−0.4			−0.4	mA
I _{OL}	Low Level Output Current			4			8	mA
T _A	Free Air Operating Temperature	−55		125	0		70	°C

'LS155 Electrical Characteristics

over recommended operating free air temperature range (unless otherwise noted)

Symbol	Parameter	Conditions	Min	Typ (Note 1)	Max	Units	
V _I	Input Clamp Voltage	V _{CC} = Min, I _I = −18 mA			−1.5	V	
V _{OH}	High Level Output Voltage	V _{CC} = Min, I _{OH} = Max V _{IL} = Max, V _{IH} = Min	DM54	2.5	3.4	V	
			DM74	2.7	3.4		
V _{OL}	Low Level Output Voltage	V _{CC} = Min, I _{OL} = Max V _{IL} = Max, V _{IH} = Min	DM54		0.25	0.4	V
			DM74		0.35	0.5	
			DM74		0.25	0.4	
I _I	Input Current @ Max Input Voltage	V _{CC} = Max, V _I = 7V			0.1	mA	
I _{IH}	High Level Input Current	V _{CC} = Max, V _I = 2.7V			20	μA	
I _{IL}	Low Level Input Current	V _{CC} = Max, V _I = 0.4V			−0.36	mA	
I _{OS}	Short Circuit Output Current	V _{CC} = Max (Note 2)	DM54	−20		−100	mA
			DM74	−20		−100	
I _{CC}	Supply Current	V _{CC} = Max (Note 3)		6.1	10	mA	

Note 1: All typicals are at V_{CC} = 5V, T_A = 25° C.

Note 2: Not more than one output should be shorted at a time, and the duration should not exceed one second.

Note 3: I_{CC} is measured with all outputs open, A,B, and C1 inputs at 4.5V, and C2, G1, and G2 inputs grounded.

'LS155 Switching Characteristics

at $V_{CC} = 5V$ and $T_A = 25^\circ C$ (See Section 1 for Test Waveforms and Output Load)

Symbol	Parameter	From (Input) To (Output)	$R_L = 2 k\Omega$				Units
			$C_L = 15 pF$		$C_L = 50 pF$		
			Min	Max	Min	Max	
t_{PLH}	Propagation Delay Time Low to High Level Output	A, B, C2, G1 or G2 to Y		18		22	ns
t_{PHL}	Propagation Delay Time High to Low Level Output	A, B, C2, G1 or G2 to Y		27		35	ns
t_{PLH}	Propagation Delay Time Low to High Level Output	A or B to Y		18		24	ns
t_{PHL}	Propagation Delay Time High to Low Level Output	A or B to Y		27		35	ns
t_{PLH}	Propagation Delay Time Low to High Level Output	C1 to Y		20		24	ns
t_{PHL}	Propagation Delay Time High to Low Level Output	C1 to Y		27		35	ns

Recommended Operating Conditions

Symbol	Parameter	DM54LS156			DM74LS156			Units
		Min	Nom	Max	Min	Nom	Max	
V_{CC}	Supply Voltage	4.5	5	5.5	4.75	5	5.25	V
V_{IH}	High Level Input Voltage	2			2			V
V_{IL}	Low Level Input Voltage			0.7			0.8	V
V_{OH}	High Level Output Voltage			5.5			5.5	V
I_{OL}	Low Level Output Current			4			8	mA
T_A	Free Air Operating Temperature	-55		125	0		70	$^\circ C$

'LS156 Electrical Characteristics

over recommended operating free air temperature range (unless otherwise noted)

Symbol	Parameter	Conditions	Min	Typ (Note 1)	Max	Units
V_I	Input Clamp Voltage	$V_{CC} = \text{Min}, I_I = -18 \text{ mA}$			-1.5	V
I_{CEX}	High Level Output Current	$V_{CC} = \text{Min}, V_O = 5.5V$ $V_{IL} = \text{Max}, V_{IH} = \text{Min}$			100	μA
V_{OL}	Low Level Output Voltage	$V_{CC} = \text{Min}, I_{OL} = \text{Max}$ $V_{IL} = \text{Max}, V_{IH} = \text{Min}$	DM54	0.25	0.4	V
			DM74	0.35	0.5	
		$I_{OL} = 4 \text{ mA}, V_{CC} = \text{Min}$	DM74	0.25	0.4	
I_I	Input Current @ Max Input Voltage	$V_{CC} = \text{Max}, V_I = 7V$			0.1	mA
I_{IH}	High Level Input Current	$V_{CC} = \text{Max}, V_I = 2.7V$			20	μA
I_{IL}	Low Level Input Current	$V_{CC} = \text{Max}, V_I = 0.4V$			-0.36	mA
I_{CC}	Supply Current	$V_{CC} = \text{Max}$ (Note 2)		6.1	10	mA

Note 1: All typicals are at $V_{CC} = 5V, T_A = 25^\circ C$.

Note 2: I_{CC} is measured with all outputs open, A, B, and C1 inputs at 4.5V, and C2, G1, and G2 grounded.

'LS156 Switching Characteristics

at $V_{CC} = 5V$ and $T_A = 25^\circ C$ (See Section 1 for Test Waveforms and Output Load)

Symbol	Parameter	From (Input) To (Output)	$R_L = 2\text{ k}\Omega$				Units
			$C_L = 15\text{ pF}$		$C_L = 50\text{ pF}$		
			Min	Max	Min	Max	
t_{PLH}	Propagation Delay Time Low to High Level Output	A, B, C2, G1 or G2 to Y		28		53	ns
t_{PHL}	Propagation Delay Time High to Low Level Output	A, B, C2, G1 or G2 to Y		33		43	ns
t_{PLH}	Propagation Delay Time Low to High Level Output	A or B to Y		28		53	ns
t_{PHL}	Propagation Delay Time High to Low Level Output	A or B to Y		33		43	ns
t_{PLH}	Propagation Delay Time Low to High Level Output	C1 to Y		28		53	ns
t_{PHL}	Propagation Delay Time High to Low Level Output	C1 to Y		34		43	ns

Logic Diagram

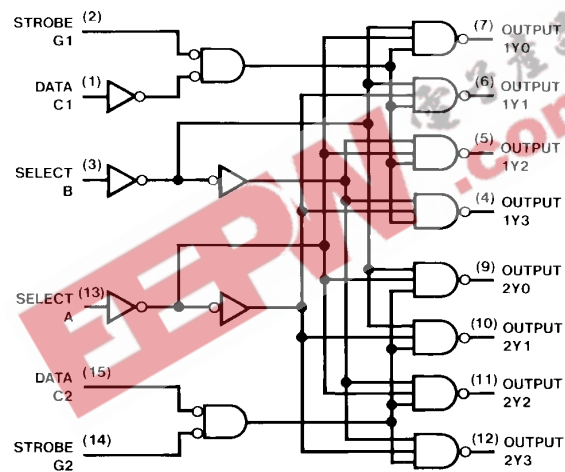

TL/F/6395-2

EEPW 电子产品世界
.com.cn

Physical Dimensions inches (millimeters)

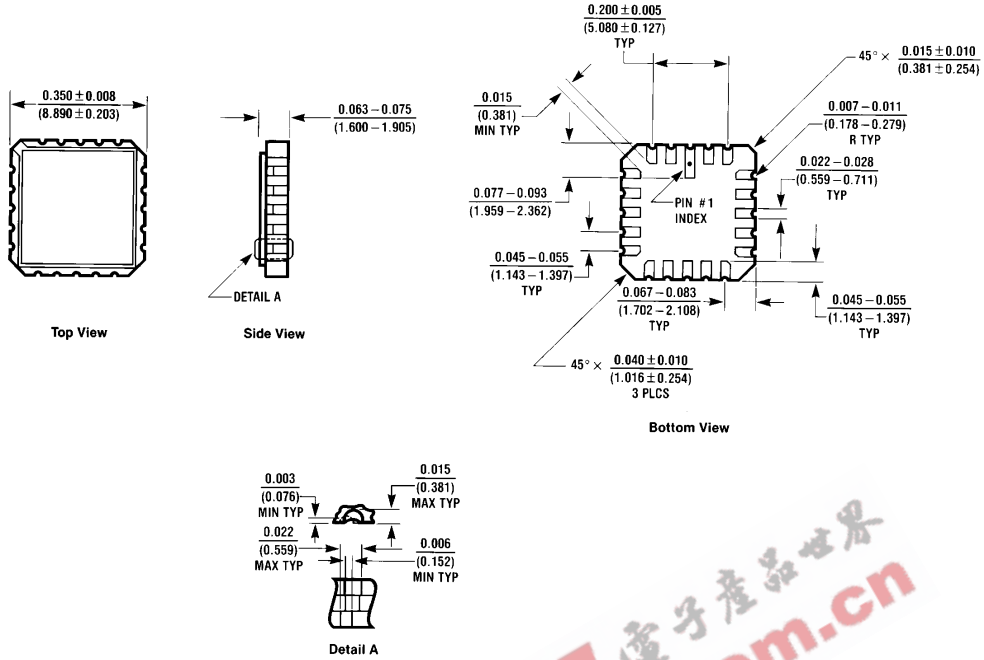

Ceramic Leadless Chip Carrier (E)
Order Number 54LS155LMQB
NS Package Number E20A

E20A (REV D)

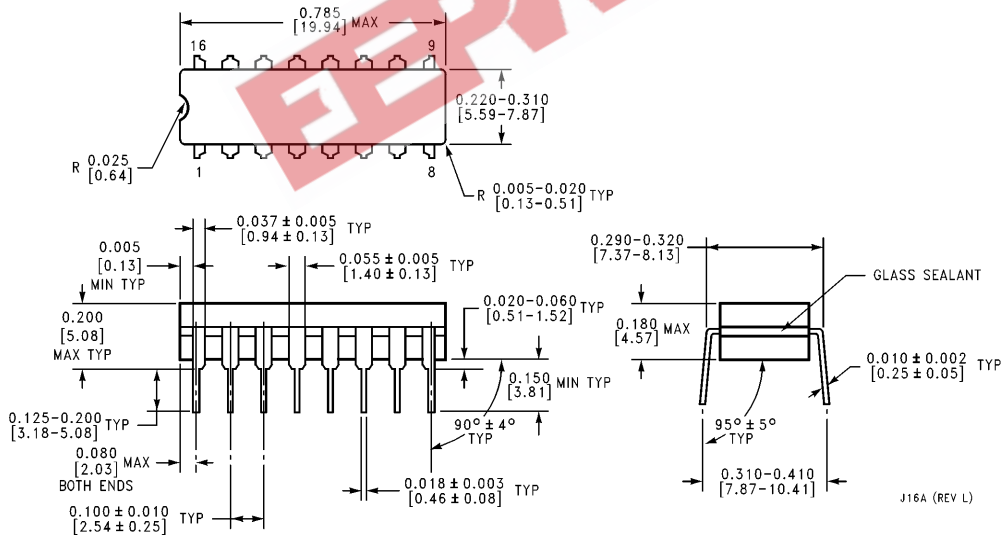

16-Lead Ceramic Dual-In-Line Package (J)
Order Number 54LS155DMQB, 54LS156DMQB, DM54LS155J or DM54LS156J
NS Package Number J16A

J16A (REV L)

Physical Dimensions inches (millimeters) (Continued)

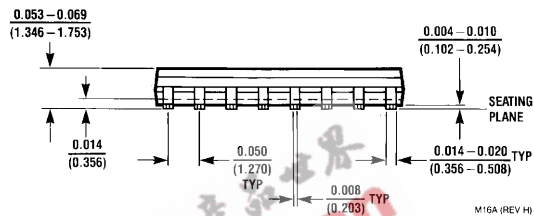
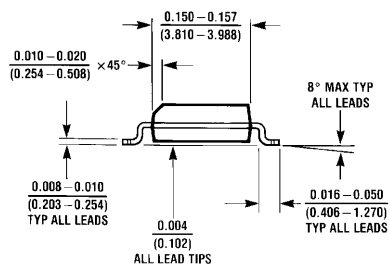
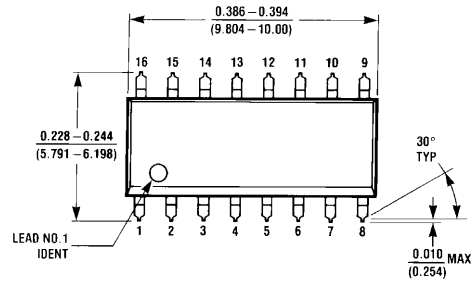

16-Lead Small Outline Molded Package (M)
Order Number DM74LS155M or DM74LS156M
NS Package Number M16A

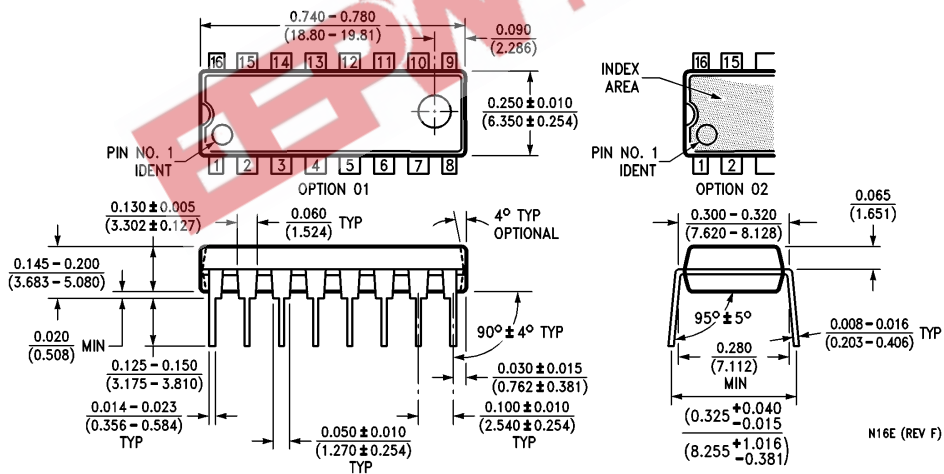

16-Lead Molded Dual-In-Line Package (N)
Order Number DM74LS155N or DM74LS156N
NS Package Number N16E

Physical Dimensions inches (millimeters) (Continued)

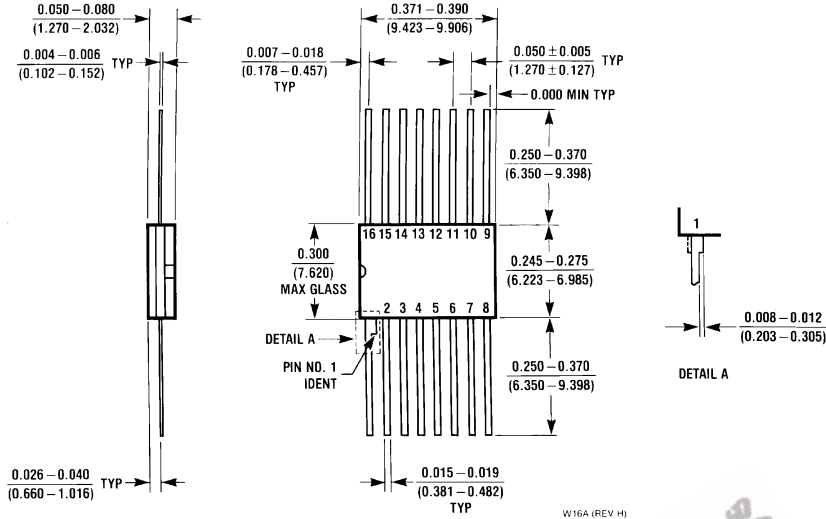

16-Lead Ceramic Flat Package (W)
Order Number 54LS155FMQB, 54LS156FMQB, DM54LS155W or DM54LS156W
NS Package Number W16A



LIFE SUPPORT POLICY

NATIONAL'S PRODUCTS ARE NOT AUTHORIZED FOR USE AS CRITICAL COMPONENTS IN LIFE SUPPORT DEVICES OR SYSTEMS WITHOUT THE EXPRESS WRITTEN APPROVAL OF THE PRESIDENT OF NATIONAL SEMICONDUCTOR CORPORATION. As used herein:

1. Life support devices or systems are devices or systems which, (a) are intended for surgical implant into the body, or (b) support or sustain life, and whose failure to perform, when properly used in accordance with instructions for use provided in the labeling, can be reasonably expected to result in a significant injury to the user.
2. A critical component is any component of a life support device or system whose failure to perform can be reasonably expected to cause the failure of the life support device or system, or to affect its safety or effectiveness.



National Semiconductor Corporation
 1111 West Bardin Road
 Arlington, TX 76017
 Tel: 1(800) 272-9959
 Fax: 1(800) 737-7018

National Semiconductor Europe
 Fax: (+49) 0-180-530 85 86
 Email: cnjwge@tevm2.nsc.com
 Deutsch Tel: (+49) 0-180-530 85 85
 English Tel: (+49) 0-180-532 78 32
 Français Tel: (+49) 0-180-532 93 58
 Italiano Tel: (+49) 0-180-534 16 80

National Semiconductor Hong Kong Ltd.
 13th Floor, Straight Block,
 Ocean Centre, 5 Canton Rd.
 Tsimshatsui, Kowloon
 Hong Kong
 Tel: (852) 2737-1600
 Fax: (852) 2736-9960

National Semiconductor Japan Ltd.
 Tel: 81-043-299-2309
 Fax: 81-043-299-2408

National does not assume any responsibility for use of any circuitry described, no circuit patent licenses are implied and National reserves the right at any time without notice to change said circuitry and specifications.