

DM64ALS08/DM74ALS08 Quad 2-Input AND Gate

General Description

This device contains four independent gates, each of which performs the logic AND function.

The DM64ALS08 version features the same performance as the standard version DM74ALS08 with a guarantee over an extended temperature range (-40°C to $+85^{\circ}\text{C}$).

Features

- Switching specifications at 50 pF
- Switching specifications guaranteed over full temperature and V_{CC} range

- Advanced oxide-isolated, ion-implanted Schottky TTL process
- Functionally and pin for pin compatible with Schottky and low power Schottky TTL counterpart
- Improved AC performance over Schottky and low power Schottky counterparts
- DM64ALS08 guaranteed over extended temperature -40°C to $+85^{\circ}\text{C}$

Connection Diagram

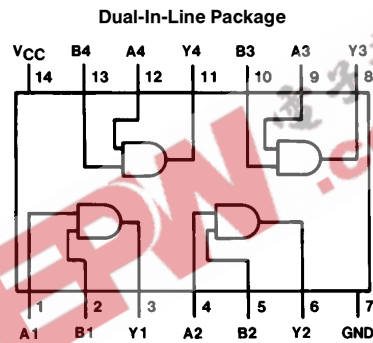

TL/F/6271-1

Order Number **DM64ALS08M**, **DM64ALS08N**, **DM74ALS08M**, **DM74ALS08N** or **DM74ALS08SJ**
See NS Package Number M14A, M14D or N14A

Function Table

$$Y = AB$$

Inputs		Output
A	B	Y
L	L	L
L	H	L
H	L	L
H	H	H

H = High Logic Level
L = Low Logic Level

Absolute Maximum Ratings

Supply Voltage	7V
Input Voltage	7V
Operating Free Air Temperature Range	
DM74ALS	0°C to +70°C
DM64ALS	-40°C to +85°C
Storage Temperature Range	-65°C to +150°C
Typical θ_{JA}	
N Package	89°C/W
M Package	120°C/W

Note: The "Absolute Maximum Ratings" are those values beyond which the safety of the device cannot be guaranteed. The device should not be operated at these limits. The parametric values defined in the "Electrical Characteristics" table are not guaranteed at the absolute maximum ratings. The "Recommended Operating Conditions" table will define the conditions for actual device operation.

Recommended Operating Conditions

Symbol	Parameter	DM64ALS08			DM74ALS08			Units
		Min	Nom	Max	Min	Nom	Max	
V_{CC}	Supply Voltage	4.5	5	5.5	4.5	5	5.5	V
V_{IH}	High Level Input Voltage	2			2			V
V_{IL}	Low Level Input Voltage			0.8			0.8	V
I_{OH}	High Level Output Current			-0.4			-0.4	mA
I_{OL}	Low Level Output Current			8			8	mA
T_A	Free Air Operating Temperature	-40		85	0		70	°C

Electrical Characteristics

over recommended operating free air temperature range. All typical values are measured at $V_{CC} = 5V$, $T_A = 25^\circ C$.

Symbol	Parameter	Conditions	Min	Typ	Max	Units
V_{IK}	Input Clamp Voltage	$V_{CC} = 4.5V$, $I_I = -18 mA$			-1.5	V
V_{OH}	High Level Output Voltage	$I_{OH} = -0.4 mA$ $V_{CC} = 4.5V$ to $5.5V$	$V_{CC} - 2$			V
V_{OL}	Low Level Output Voltage	$V_{CC} = 4.5V$ $I_{OL} = 4 mA$ $I_{OL} = 8 mA$		0.25	0.4	V
				0.35	0.5	V
I_I	Input Current @ Max. Input Voltage	$V_{CC} = 5.5V$, $V_{IH} = 7V$			0.1	mA
I_{IH}	High Level Input Current	$V_{CC} = 5.5V$, $V_{IH} = 2.7V$			20	μA
I_{IL}	Low Level Input Current	$V_{CC} = 5.5V$, $V_{IL} = 0.4V$			-0.1	mA
I_O	Output Drive Current	$V_{CC} = 5.5V$ $V_O = 2.25V$	-30		-112	mA
I_{CC}	Supply Current	$V_{CC} = 5.5V$	Outputs High	1.3	2.4	mA
			Outputs Low	2.2	4	mA

Switching Characteristics

over recommended operating free air temperature range (Note 1).

Symbol	Parameter	Conditions	DM64ALS08		DM74ALS08		Units
			Min	Max	Min	Max	
t_{PLH}	Propagation Delay Time Low to High Level Output	$V_{CC} = 4.5V$ to $5.5V$ $R_L = 500\Omega$ $C_L = 50 pF$	4	14	4	14	ns
t_{PHL}	Propagation Delay Time High to Low Level Output		3	10	3	10	ns

Note 1: See Section 5 for test waveforms and output load.

Physical Dimensions inches (millimeters)

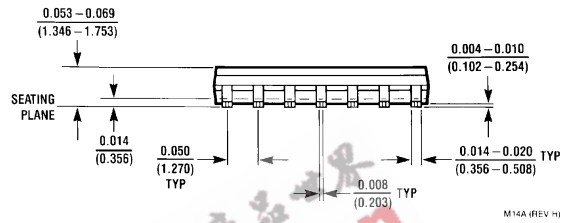
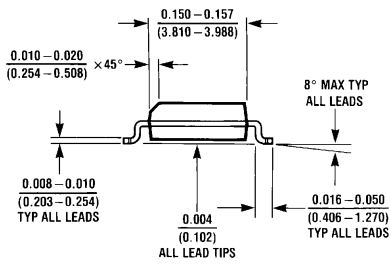
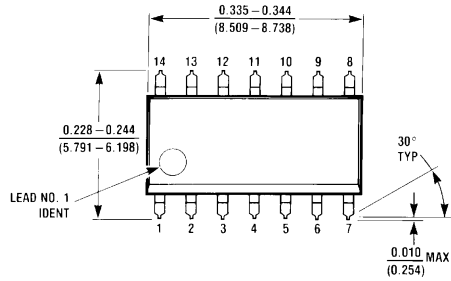

S.O. Package (M)
Order Number DM64ALS08M or DM74ALS08M
NS Package Number M14A

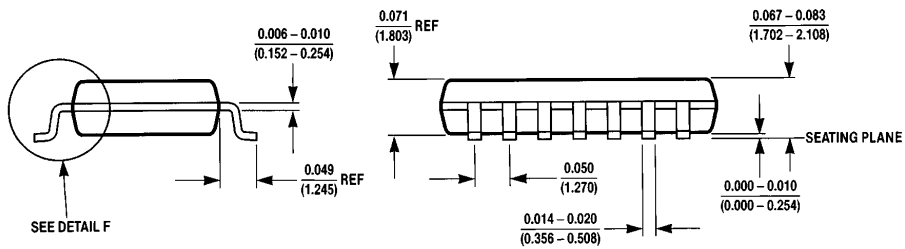
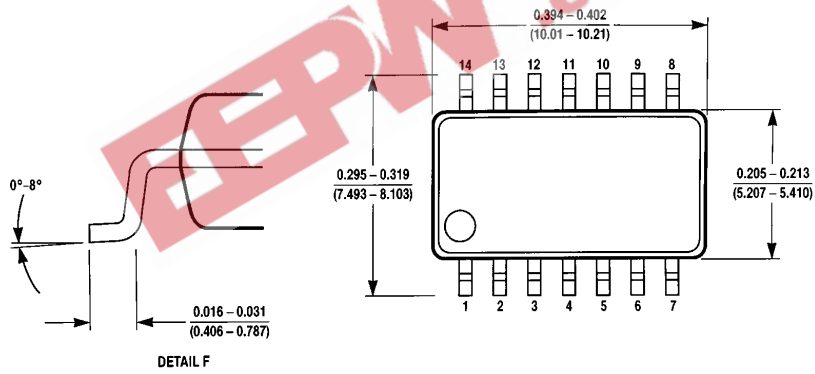

Small Outline Package (SJ)
Order Number DM74ALS08SJ
NS Package Number M14D

Physical Dimensions inches (millimeters) (Continued)

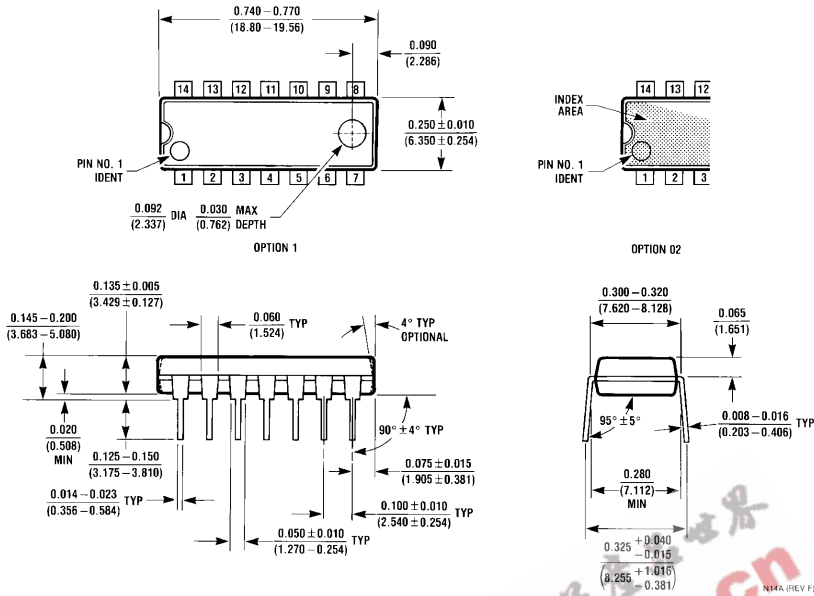

Molded Dual-In-Line Package (N)
Order Number DM64ALS08N or DM74ALS08N
NS Package Number N14A

LIFE SUPPORT POLICY

NATIONAL'S PRODUCTS ARE NOT AUTHORIZED FOR USE AS CRITICAL COMPONENTS IN LIFE SUPPORT DEVICES OR SYSTEMS WITHOUT THE EXPRESS WRITTEN APPROVAL OF THE PRESIDENT OF NATIONAL SEMICONDUCTOR CORPORATION. As used herein:

1. Life support devices or systems are devices or systems which, (a) are intended for surgical implant into the body, or (b) support or sustain life, and whose failure to perform, when properly used in accordance with instructions for use provided in the labeling, can be reasonably expected to result in a significant injury to the user.
2. A critical component is any component of a life support device or system whose failure to perform can be reasonably expected to cause the failure of the life support device or system, or to affect its safety or effectiveness.



National Semiconductor Corporation
 1111 West Bardin Road
 Arlington, TX 76017
 Tel: 1(800) 272-9959
 Fax: 1(800) 737-7018

National Semiconductor Europe
 Fax: (+49) 0-180-530 85 86
 Email: cnjwge@levm2.nsc.com
 Deutsch Tel: (+49) 0-180-530 85 85
 English Tel: (+49) 0-180-532 78 32
 Français Tel: (+49) 0-180-532 93 58
 Italiano Tel: (+49) 0-180-534 16 80

National Semiconductor Hong Kong Ltd.
 13th Floor, Straight Block,
 Ocean Centre, 5 Canton Rd.
 Tsimshatsui, Kowloon
 Hong Kong
 Tel: (852) 2737-1600
 Fax: (852) 2736-9960

National Semiconductor Japan Ltd.
 Tel: 81-043-299-2309
 Fax: 81-043-299-2408

National does not assume any responsibility for use of any circuitry described, no circuit patent licenses are implied and National reserves the right at any time without notice to change said circuitry and specifications.