

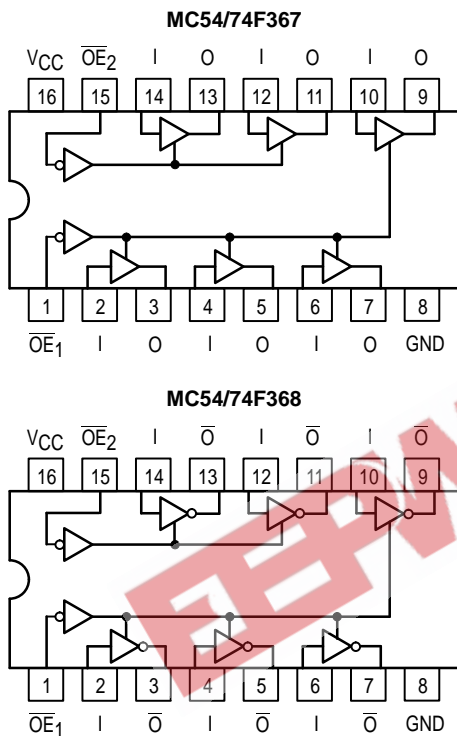

HEX BUFFER/DRIVER 4-BIT PLUS 2-BIT, NONINVERTING AND INVERTING, 3-STATE

CONNECTION DIAGRAMS



FUNCTION TABLE

Inputs		Outputs	
\overline{OE}	I	O	\overline{O}
L	L	L	H
L	H	H	L
H	X	Z	Z

H = HIGH Voltage Level
L = LOW Voltage Level
X = Don't Care
Z = High Impedance

**MC54/74F367
MC54/74F368**

**F367
HEX BUFFER/DRIVER
4-BIT PLUS 2-BIT,
NONINVERTING 3-STATE**

**F368
HEX BUFFER/DRIVER
4-BIT PLUS 2-BIT,
INVERTING 3-STATE
FAST™ SCHOTTKY TTL**

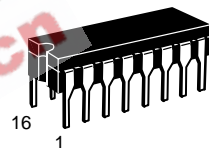

**J SUFFIX
CERAMIC
CASE 620-09**

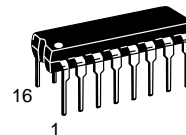

**N SUFFIX
PLASTIC
CASE 648-08**

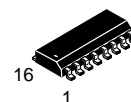

**D SUFFIX
SOIC
CASE 751B-03**

ORDERING INFORMATION

MC54FXXXJ Ceramic
MC74FXXXN Plastic
MC74FXXXD SOIC

GUARANTEED OPERATING RANGES

Symbol	Parameter		Min	Typ	Max	Unit
V_{CC}	Supply Voltage	54, 74	4.5	5.0	5.5	V
T_A	Operating Ambient Temperature Range	54	-55	25	125	°C
		74	0	25	70	
I_{OH}	Output Current — High	54			-12	mA
		74			-15	
I_{OL}	Output Current — Low	54			48	mA
		74			64	

MC54/74F367 • MC54/74F368

DC CHARACTERISTICS OVER OPERATING TEMPERATURE RANGE (unless otherwise specified)

Symbol	Parameter	Limits			Unit	Test Conditions		
		Min	Typ	Max				
V _{IH}	Input HIGH Voltage	2.0			V	Guaranteed Input HIGH Voltage		
V _{IL}	Input LOW Voltage			0.8	V	Guaranteed Input LOW Voltage		
V _{IK}	Input Clamp Diode Voltage			-1.2	V	I _{IN} = -18 mA	V _{CC} = MIN	
V _{OH}	Output HIGH Voltage	54, 74	2.4	3.4		V	I _{OH} = -3.0 mA	V _{CC} = 4.5 V
		74	2.7	3.4		V	I _{OH} = -3.0 mA	V _{CC} = 4.75 V
		54	2.0			V	I _{OH} = -12 mA	V _{CC} = 4.5 V
		74	2.0			V	I _{OH} = -15 mA	V _{CC} = 4.5 V
V _{OL}	Output LOW Voltage	54		0.35	0.55	V	I _{OL} = 48 mA	V _{CC} = MAX
		74		0.4	0.55	V	I _{OL} = 64 mA	
I _{OZH}	Output Off Current HIGH			50	μA	V _{OUT} = 2.7 V	V _{CC} = MAX	
I _{OZL}	Output Off Current LOW			-50	μA	V _{OUT} = 0.5 V	V _{CC} = MAX	
I _{IH}	Input HIGH Current			20	μA	V _{IN} = 2.7 V	V _{CC} = MAX	
				100	μA	V _{IN} = 7.0 V	V _{CC} = 0 V	
I _{IL}	Input LOW Current			-20	μA	V _{IN} = 0.5 V	V _{CC} = MAX	
I _{OS}	Output Short Circuit Current (Note 2)	-100		-225	mA	V _{OUT} = GND	V _{CC} = MAX	
I _{CC}	F367	I _{CC} H			35	mA	V _{CC} = MAX	
		I _{CC} L			62			
		I _{CC} Z			48			
	F368	I _{CC} H			25			
		I _{CC} L			62			
		I _{CC} Z			48			

NOTES:

- For conditions shown as MIN or MAX, use the appropriate value specified under recommended operating conditions for the applicable device type.
- Not more than one output should be shorted at a time, nor for more than 1 second.

AC CHARACTERISTICS

Symbol	Parameter	54/74F			54F		74F		Unit		
		T _A = +25°C			T _A = -55°C to +125°C		T _A = 0°C to +70°C				
		Min	Typ	Max	Min	Max	Min	Max			
t _{PLH}	Propagation Delay	F367		2.0	4.5	6.5	2.0	8.0	2.0	7.0	ns
t _{PHL}	I _n to O _n	F367		3.0	5.5	7.0	3.0	8.5	3.0	7.5	
t _{PLH}	Propagation Delay	F368		2.0	5.0	6.5	2.0	8.5	2.0	7.5	ns
t _{PHL}	I _n to \bar{O}_n	F368		1.0	3.0	5.0	1.0	6.5	1.0	5.5	
t _{PZH}	Output Enable Time	F367		2.5	5.5	7.5	2.5	9.5	2.5	8.5	ns
t _{PZL}	to HIGH and LOW Level	F367		3.0	6.5	8.5	3.0	10	3.0	9.0	
t _{PHZ}	Output Disable Time	F367		2.5	4.5	6.5	2.5	8.0	2.5	7.0	ns
t _{PLZ}	from HIGH and LOW Level	F367		1.5	4.0	6.0	1.5	7.5	1.5	6.5	