

MC12095

2.5 GHz Low Power Prescaler With Stand-By Mode

Description

The MC12095 is a single modulus prescaler for low power frequency division of a 2.5 GHz high frequency input signal. MOSAIC V™ technology is utilized to achieve low power dissipation of 24 mW at a minimum supply voltage of 2.7 V.

On-chip output termination provides output current to drive a 2.0 pF (typical) high impedance load. If additional drive is required for the prescaler output, an external resistor can be added in parallel from the OUT pin to GND to increase the output power. Care must be taken not to exceed the maximum allowable current through the output.

Divide ratio control input (SW) selects the required divide ratio of ÷2 or ÷4. Stand-By mode is available to reduce current drain to 100 µA typical when the standby pin SB is switched LOW disabling the prescaler.

Features

- 2.5 GHz Toggle Frequency
- Supply Voltage 2.7 V to 5.5 Vdc
- Low Power 8.7 mA Typical
- Operating Temperature -40°C to 85°C
- Divide by 2 or 4 Selected by the SW Pin
- Pb-Free Packages are Available

Table 1. FUNCTIONAL TABLE

SW	Divide Ratio
H	2
L	4

1. SW: H = ($V_{CC} - 0.4$ V) to V_{CC} ; L = OPEN
2. SB: H = 2.0 V to V_{CC} ; L = GND to 0.8 V

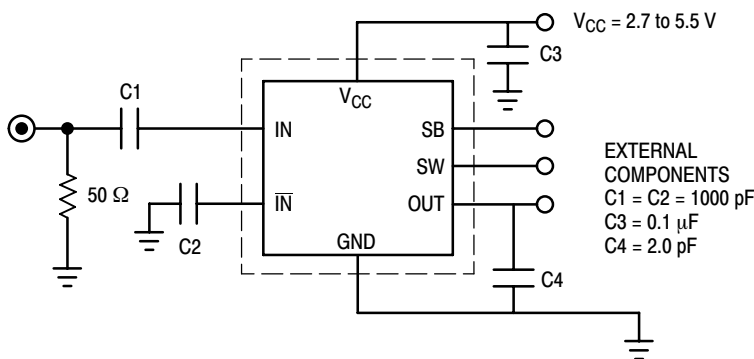

Figure 1. AC Test Circuit



ON Semiconductor™

<http://onsemi.com>

MARKING DIAGRAMS



SO-8
D SUFFIX
CASE 751

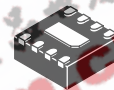
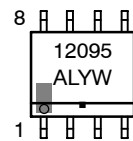

DFN8
MN SUFFIX
CASE 506AA

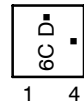

- A = Assembly Location
 - L = Wafer Lot
 - Y = Year
 - W = Work Week
 - = Pb-Free Package
- (Note: Microdot may be in either location)

PIN CONNECTIONS

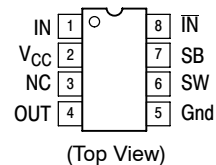

ORDERING INFORMATION

See detailed ordering and shipping information in the package dimensions section on page 6 of this data sheet.

MC12095

Table 2. ATTRIBUTES

Characteristics	Value	
Internal Input Pulldown Resistor	N/A	
Internal Input Pullup Resistor	N/A	
ESD Protection	Human Body Model Machine Model Charged Device Model	> 4 kV > 200 V > 2 kV
Moisture Sensitivity, Indefinite Time Out of Drypack (Note 1)	Pb Pkg	Pb-Free Pkg
	SOIC-8 DFN8	Level 1 Level 1
Flammability Rating	Oxygen Index: 28 to 34	UL 94 V-0 @ 0.125 in
Transistor Count	125 Devices	
Meets or exceeds JEDEC Spec EIA/JESD78 IC Latchup Test		

1. For additional information, see Application Note AND8003/D.

Table 3. MAXIMUM RATINGS

Symbol	Rating	Value	Unit
V_{CC}	Power Supply Voltage, Pin 2	-0.5 to 6.0	Vdc
T_A	Operating Temperature Range	-40 to 85	°C
T_{stg}	Storage Temperature Range	-65 to 150	°C
I_O	Maximum Output Current, Pin 4	8.0	mA

Maximum ratings are those values beyond which device damage can occur. Maximum ratings applied to the device are individual stress limit values (not normal operating conditions) and are not valid simultaneously. If these limits are exceeded, device functional operation is not implied, damage may occur and reliability may be affected.

NOTE: ESD data available upon request.

Table 4. ELECTRICAL CHARACTERISTICS ($V_{CC} = 2.7$ to 5.5 V; $T_A = -40$ to 85°C , unless otherwise noted.)

Symbol	Characteristic	Min	Typ	Max	Unit	
f_t	Toggle Frequency (Sine Wave)	500	3.0	2.5	GHz	
I_{CC}	Supply Current	-	8.7	14	mA	
I_{SB}	Stand-By Current	-	100	200	μA	
V_{IH1}	Stand-By Input HIGH (SB)	2.0	-	$V_{CC} + 0.5$ V	V	
V_{IL1}	Stand-By Input LOW (SB)	GND	-	0.8	V	
V_{IH2}	Divide Ratio Control Input HIGH (SW)	$V_{CC} - 0.4$	V_{CC}	$V_{CC} + 0.5$ V	V	
V_{IL2}	Divide Ratio Control Input LOW (SW)	OPEN	OPEN	OPEN		
V_{OUT}	Output Voltage Swing (2pF Load)	500-1000 MHz Input 1000-1500 MHz Input 1500-2500 MHz Input	800 400 200	- 450 250	- - -	mVpp
V_{IN}	Input Voltage Sensitivity	200	-	1000	mVpp	

MC12095

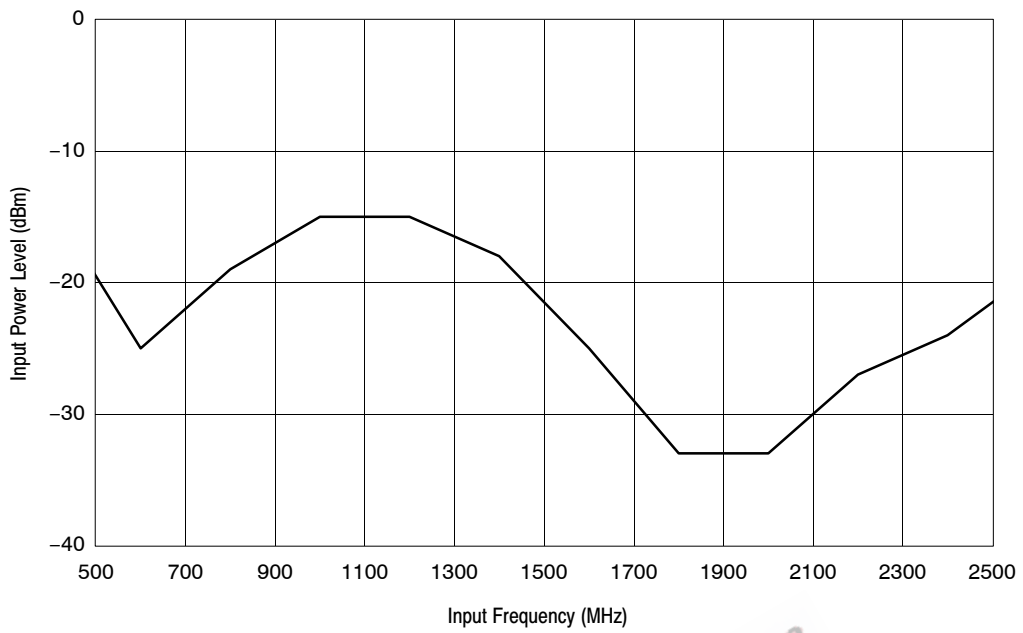

(Divide By 2 Mode, $T = 25^{\circ}\text{C}$, $V_{\text{CC}} = 2.7\text{ V}$)

Figure 2. Typical Minimum Input Sensitivity versus Input Frequency

EEPW.com.cn 电子元件世界

MC12095

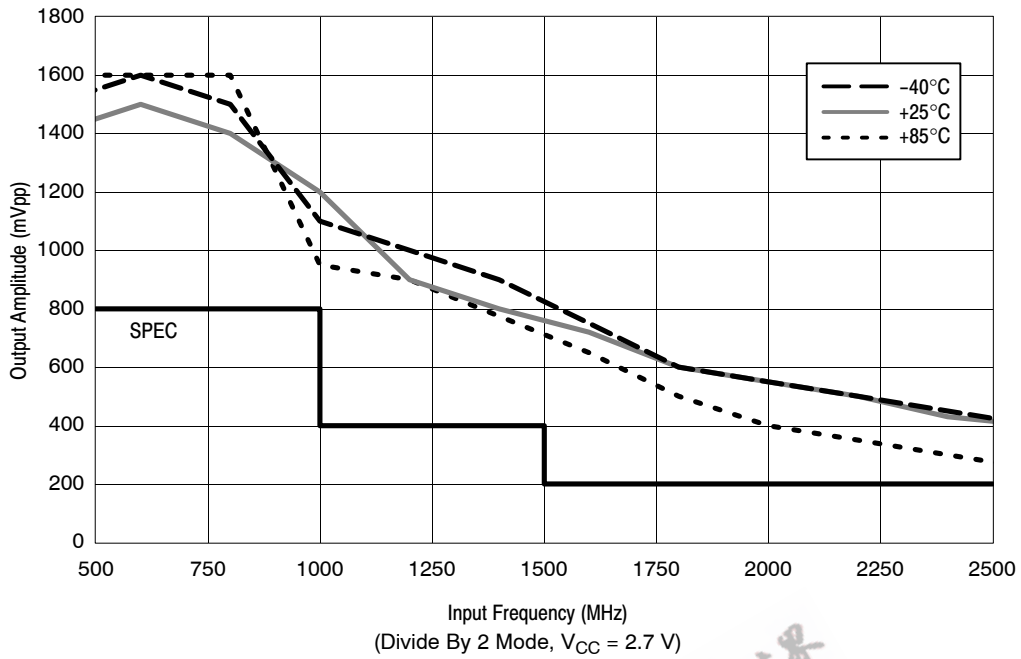

Figure 3. Typical Output Amplitude versus Frequency Over Temperature

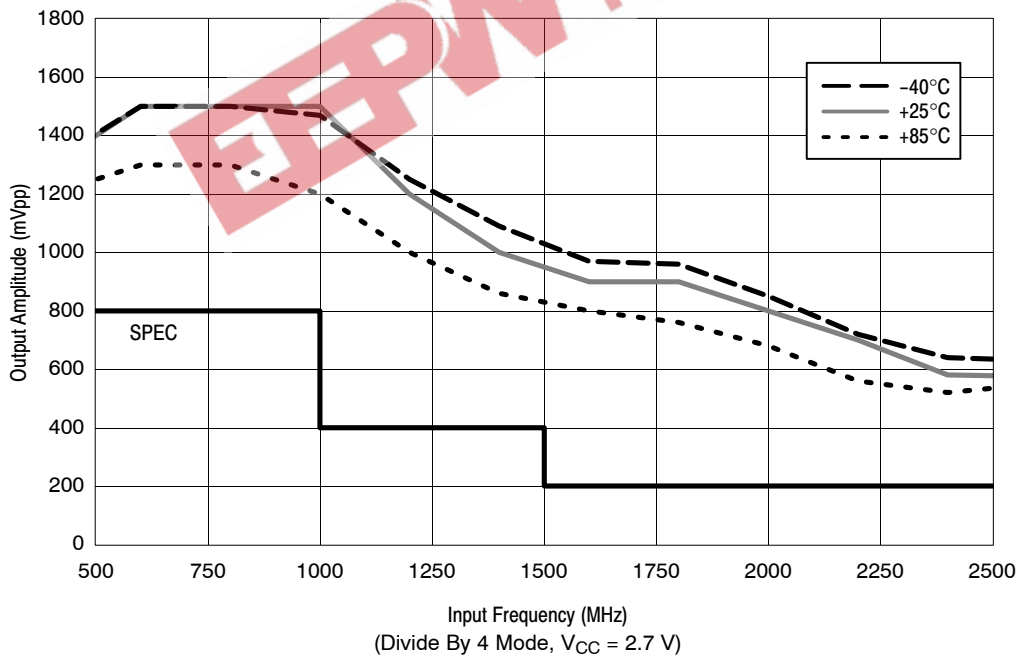

Figure 4. Typical Output Amplitude versus Frequency Over Temperature

MC12095

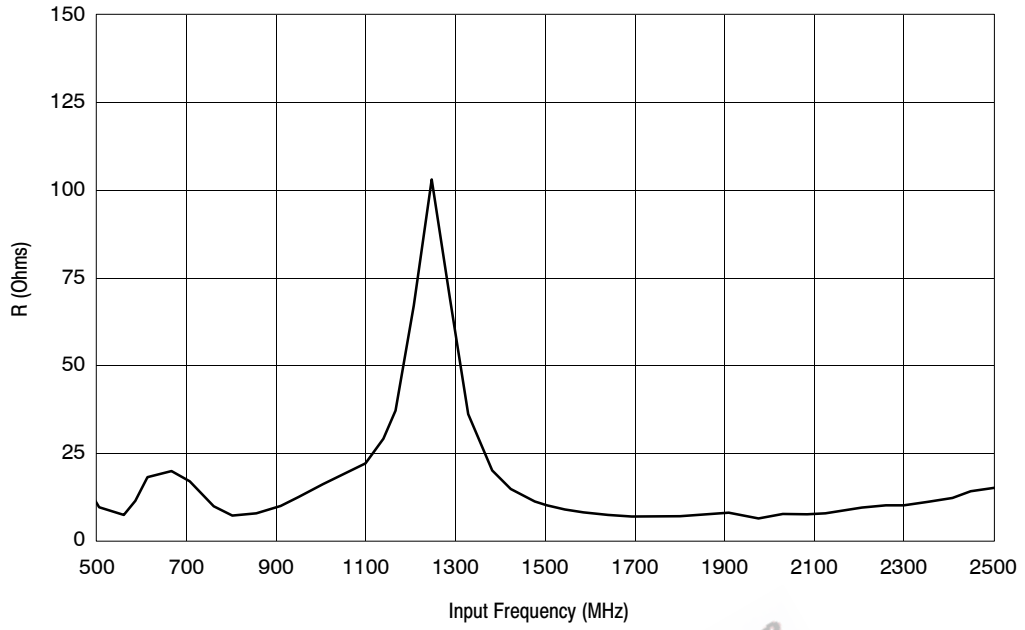

Figure 5. Input Impedance versus Frequency

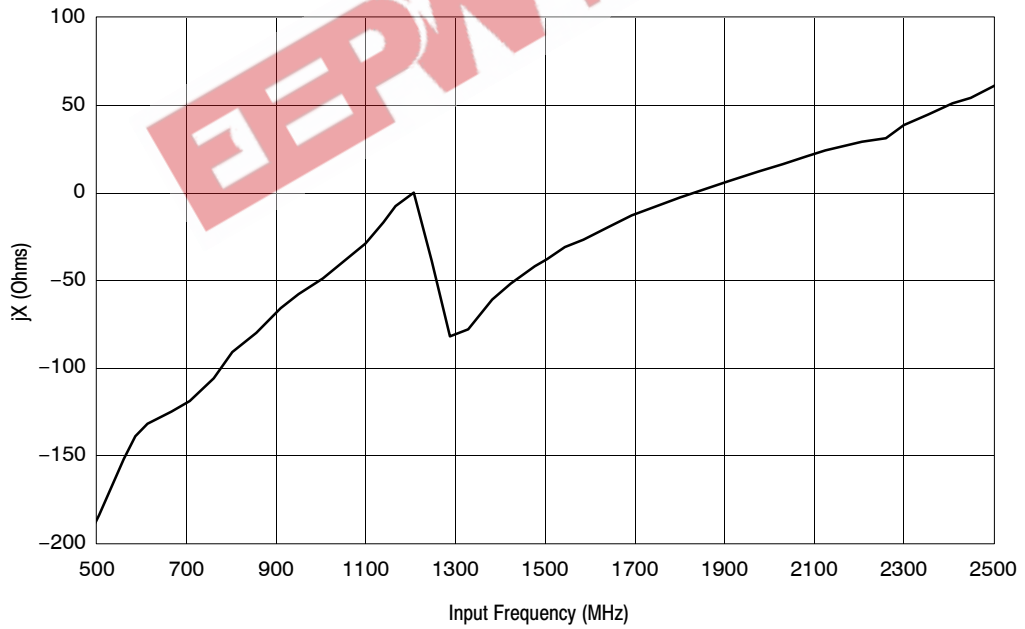

Figure 6. Input Impedance versus Frequency

MC12095

ORDERING INFORMATION

Device	Package	Shipping†
MC12095D	SOIC-8	98 Units / Rail
MC12095DG	SOIC-8 (Pb-Free)	98 Units / Rail
MC12095DR2	SOIC-8	98 Units / Rail
MC12095DR2G	SOIC-8 (Pb-Free)	98 Units / Rail
MC12095MNR4	DFN8	1000 / Tape & Reel
MC12095MNR4G	DFN8 (Pb-Free)	1000 / Tape & Reel

†For information on tape and reel specifications, including part orientation and tape sizes, please refer to our Tape and Reel Packaging Specifications Brochure, BRD8011/D.

EEPW 电子产品世界
.com.cn

MC12095

PACKAGE DIMENSIONS

SOIC-8 NB
CASE 751-07
ISSUE AG

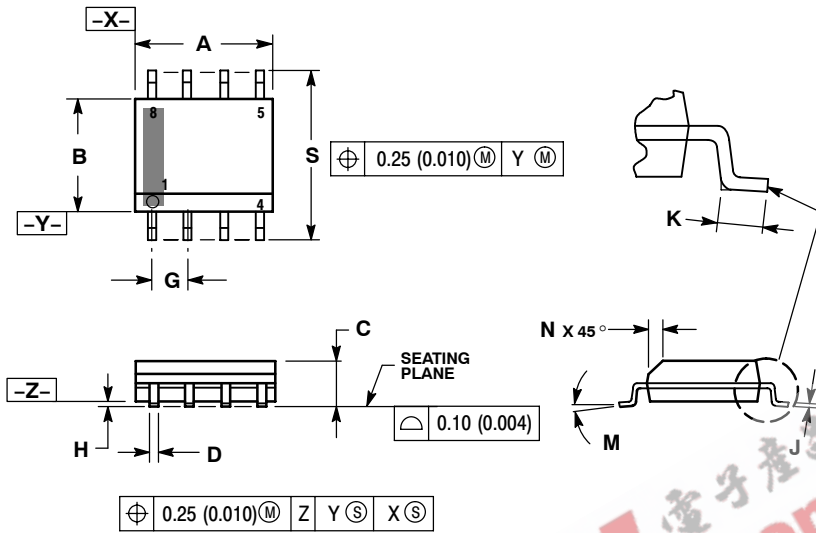

NOTES:

1. DIMENSIONING AND TOLERANCING PER ANSI Y14.5M, 1982.
2. CONTROLLING DIMENSION: MILLIMETER.
3. DIMENSION A AND B DO NOT INCLUDE MOLD PROTRUSION.
4. MAXIMUM MOLD PROTRUSION 0.15 (0.006) PER SIDE.
5. DIMENSION D DOES NOT INCLUDE DAMBAR PROTRUSION. ALLOWABLE DAMBAR PROTRUSION SHALL BE 0.127 (0.005) TOTAL IN EXCESS OF THE D DIMENSION AT MAXIMUM MATERIAL CONDITION.
6. 751-01 THRU 751-06 ARE OBSOLETE. NEW STANDARD IS 751-07.

DIM	MILLIMETERS		INCHES	
	MIN	MAX	MIN	MAX
A	4.80	5.00	0.189	0.197
B	3.80	4.00	0.150	0.157
C	1.35	1.75	0.053	0.069
D	0.33	0.51	0.013	0.020
G	1.27 BSC		0.050 BSC	
H	0.10	0.25	0.004	0.010
J	0.19	0.25	0.007	0.010
K	0.40	1.27	0.016	0.050
M	0°	8°	0°	8°
N	0.25	0.50	0.010	0.020
S	5.80	6.20	0.228	0.244

SOLDERING FOOTPRINT*

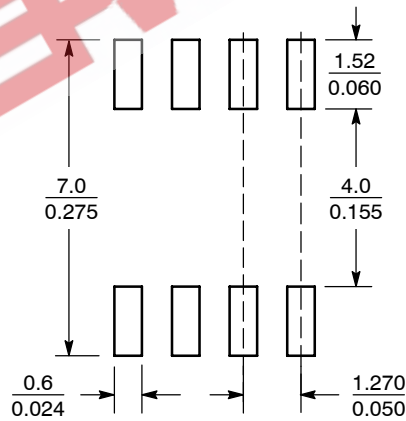

SCALE 6:1 $\left(\frac{\text{mm}}{\text{inches}}\right)$

*For additional information on our Pb-Free strategy and soldering details, please download the ON Semiconductor Soldering and Mounting Techniques Reference Manual, SOLDERRM/D.

MC12095

PACKAGE DIMENSIONS

DFN8
CASE 506AA-01
ISSUE C

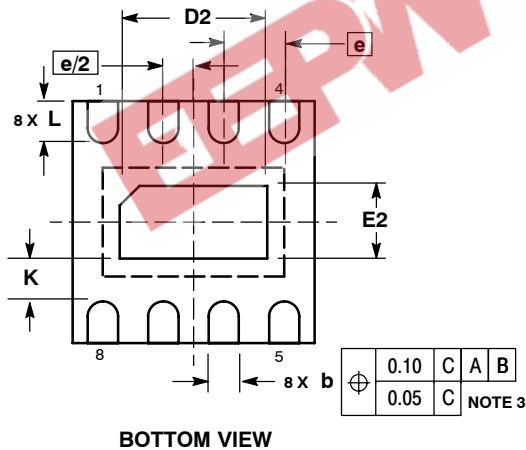
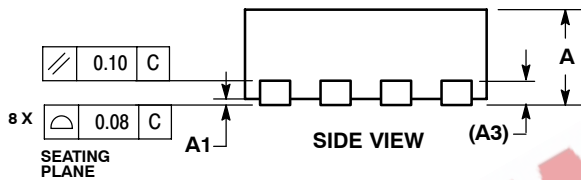
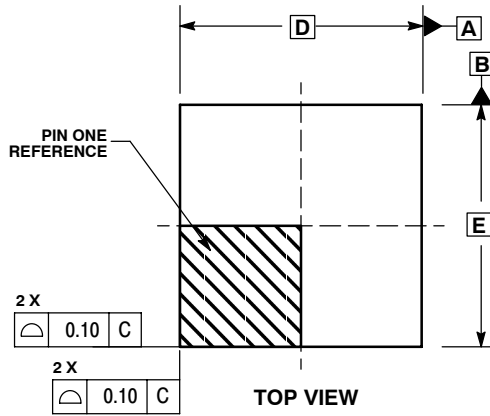

NOTES:

1. DIMENSIONING AND TOLERANCING PER ASME Y14.5M, 1994 .
2. CONTROLLING DIMENSION: MILLIMETERS.
3. DIMENSION b APPLIES TO PLATED TERMINAL AND IS MEASURED BETWEEN 0.25 AND 0.30 MM FROM TERMINAL.
4. COPLANARITY APPLIES TO THE EXPOSED PAD AS WELL AS THE TERMINALS.

DIM	MILLIMETERS	
	MIN	MAX
A	0.80	1.00
A1	0.00	0.05
A3	0.20 REF	
b	0.20	0.30
D	2.00 BSC	
D2	1.10	1.30
E	2.00 BSC	
E2	0.70	0.90
e	0.50 BSC	
K	0.20	---
L	0.25	0.35

MOSAIC V is a trademark of Motorola, Inc.

ON Semiconductor and are registered trademarks of Semiconductor Components Industries, LLC (SCILLC). SCILLC reserves the right to make changes without further notice to any products herein. SCILLC makes no warranty, representation or guarantee regarding the suitability of its products for any particular purpose, nor does SCILLC assume any liability arising out of the application or use of any product or circuit, and specifically disclaims any and all liability, including without limitation special, consequential or incidental damages. "Typical" parameters which may be provided in SCILLC data sheets and/or specifications can and do vary in different applications and actual performance may vary over time. All operating parameters, including "Typicals" must be validated for each customer application by customer's technical experts. SCILLC does not convey any license under its patent rights nor the rights of others. SCILLC products are not designed, intended, or authorized for use as components in systems intended for surgical implant into the body, or other applications intended to support or sustain life, or for any other application in which the failure of the SCILLC product could create a situation where personal injury or death may occur. Should Buyer purchase or use SCILLC products for any such unintended or unauthorized application, Buyer shall indemnify and hold SCILLC and its officers, employees, subsidiaries, affiliates, and distributors harmless against all claims, costs, damages, and expenses, and reasonable attorney fees arising out of, directly or indirectly, any claim of personal injury or death associated with such unintended or unauthorized use, even if such claim alleges that SCILLC was negligent regarding the design or manufacture of the part. SCILLC is an Equal Opportunity/Affirmative Action Employer. This literature is subject to all applicable copyright laws and is not for resale in any manner.

PUBLICATION ORDERING INFORMATION

LITERATURE FULFILLMENT:
Literature Distribution Center for ON Semiconductor
P.O. Box 61312, Phoenix, Arizona 85082-1312 USA
Phone: 480-829-7710 or 800-344-3860 Toll Free USA/Canada
Fax: 480-829-7709 or 800-344-3867 Toll Free USA/Canada
Email: orderlit@onsemi.com

N. American Technical Support: 800-282-9855 Toll Free
USA/Canada

Japan: ON Semiconductor, Japan Customer Focus Center
2-9-1 Kamimeguro, Meguro-ku, Tokyo, Japan 153-0051
Phone: 81-3-5773-3850

ON Semiconductor Website: <http://onsemi.com>

Order Literature: <http://www.onsemi.com/litorder>

For additional information, please contact your local Sales Representative.