

## DUAL 2-INPUT NAND BUFFER/DRIVER

- 32 TIMES STANDARD B-SERIES OUTPUT CURRENT DRIVE SINKING CAPABILITY  
– 136mA TYP. @  $V_{DD} = 10V$ ,  $V_{DS} = 1V$
- QUIESCENT CURRENT SPECIFIED AT 20V FOR HCC DEVICE
- 5V, 10V, AND 15V PARAMETRIC RATINGS
- INPUT CURRENT OF 100nA AT 18V AND 25°C FOR HCC DEVICE
- 100% TESTED FOR QUIESCENT CURRENT
- MEETS ALL REQUIREMENTS OF JEDEC TENTATIVE STANDARD N°. 13A, "STANDARD SPECIFICATIONS FOR DESCRIPTION OF "B" SERIES CMOS DEVICES"

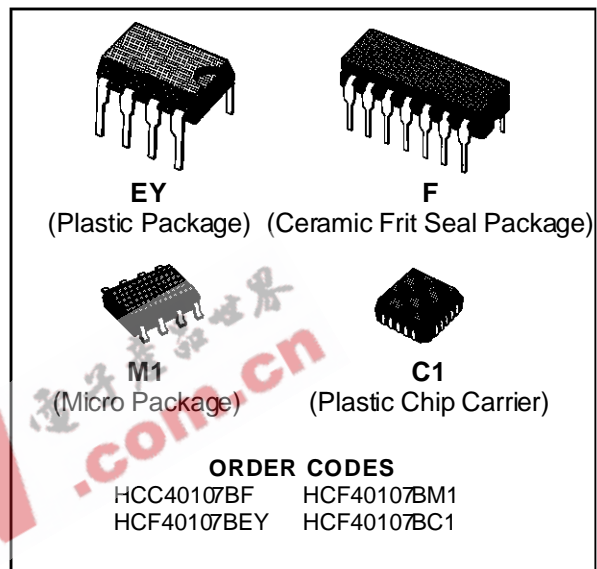

EEPW.com.cn

### DESCRIPTION

The **HCC40107B** (extended temperature range) and **HCF40107B** (intermediate temperature range) are monolithic integrated circuits, available in 14-lead dual in-line ceramic package 8-lead minidip plastic package and 8-lead plastic micropackage.

The **HCC/HCF40107B** is a dual 2-input NAND buffer/driver containing two independent 2-input NAND buffers with open-drain single n-channel transistor outputs. This device features a wired-OR capability and high output sink current capability (136mA typ. at  $V_{DD} = 10V$ ,  $V_{DS} = 1V$ ).

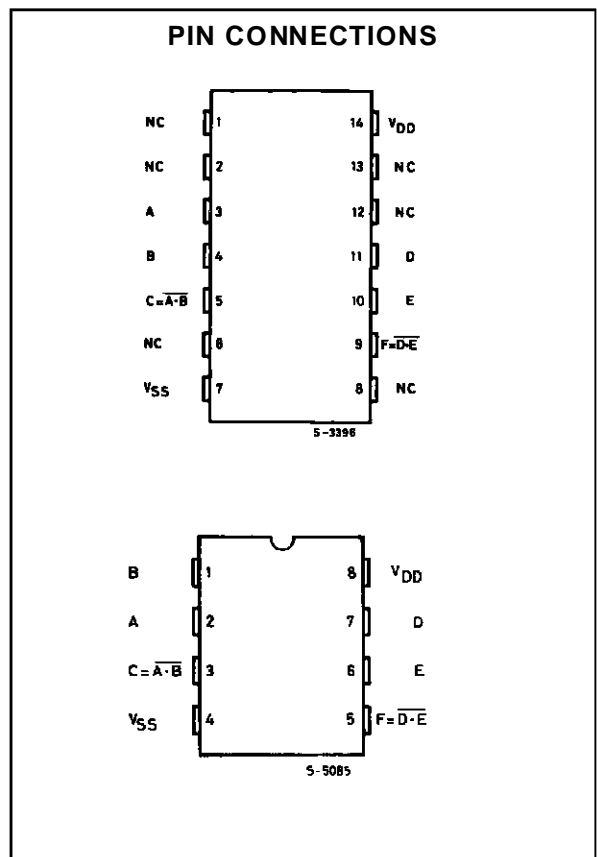

## HCC/HCF40107B

### FUNCTIONAL DIAGRAM

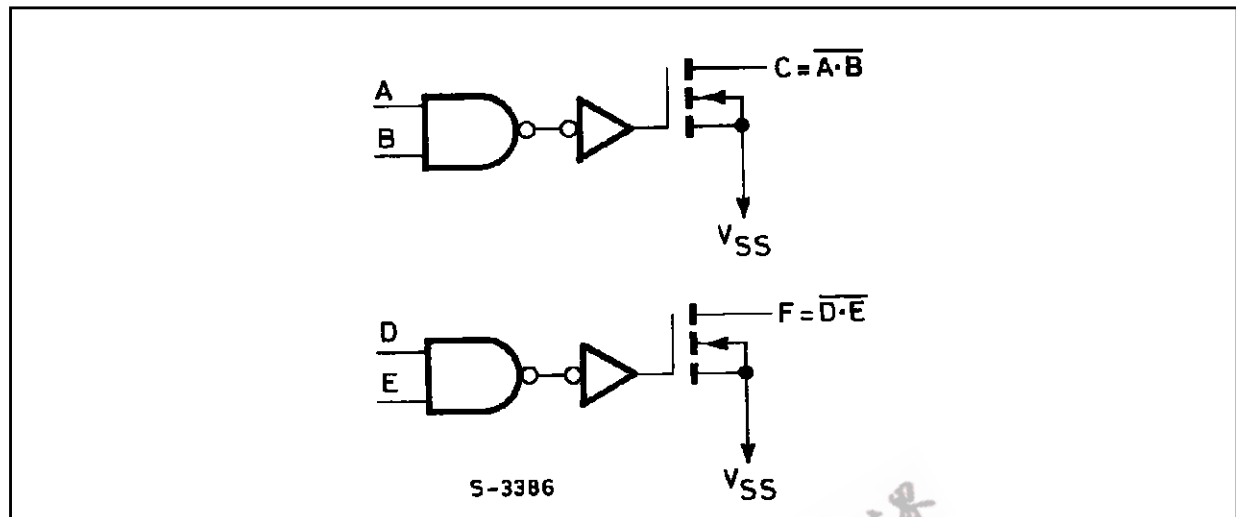

### ABSOLUTE MAXIMUM RATINGS

| Symbol     | Parameter  | Value                          | Unit        |
|------------|--|--------------------------------|-------------|
| $V_{DD}^*$ | Supply Voltage : HCC types<br>HCF types  | - 0.5 to + 20<br>- 0.5 to + 18 | V           |
| $V_i$      | Input Voltage  | - 0.5 to $V_{DD} + 0.5$        | V           |
| $I_i$      | DC Input Current (any one input)   | $\pm 10$                       | mA          |
| $P_{tot}$  | Total Power Dissipation (per package)  | 200                            | mW          |
|            | Dissipation per Output Transistor<br>for $T_{op}$ = full package-temperature Range | 100                            |             |
| $T_{op}$   | Operating Temperature : HCC types<br>HCF types                                     | - 55 to + 125<br>- 40 to + 85  | $^{\circ}C$ |
| $T_{stg}$  | Storage Temperature  | - 65 to + 150                  | $^{\circ}C$ |

Stresses above those listed under "Absolute Maximum Ratings" may cause permanent damage to the device. This is a stress rating only and functional operation of the device at these or any other conditions above those indicated in the operational sections of this specification is not implied. Exposure to absolute maximum rating conditions for external periods may affect device reliability.

\* All voltages values are referred to  $V_{SS}$  pin voltage.

### RECOMMENDED OPERATING CONDITIONS

| Symbol   | Parameter                                      | Value         | Unit        |
|----------|--|---------------|-------------|
| $V_{DD}$ | Supply Voltage : HCC Types<br>HCF Types        | 3 to 18       | V           |
|          |  | 3 to 15       | V           |
| $V_i$    | Input Voltage                                  | 0 to $V_{DD}$ | V           |
| $T_{op}$ | Operating Temperature : HCC Types<br>HCF Types | - 55 to + 125 | $^{\circ}C$ |
|          |  | - 40 to + 85  | $^{\circ}C$ |

**SCHEMATIC DIAGRAM AND TRUTH TABLE**

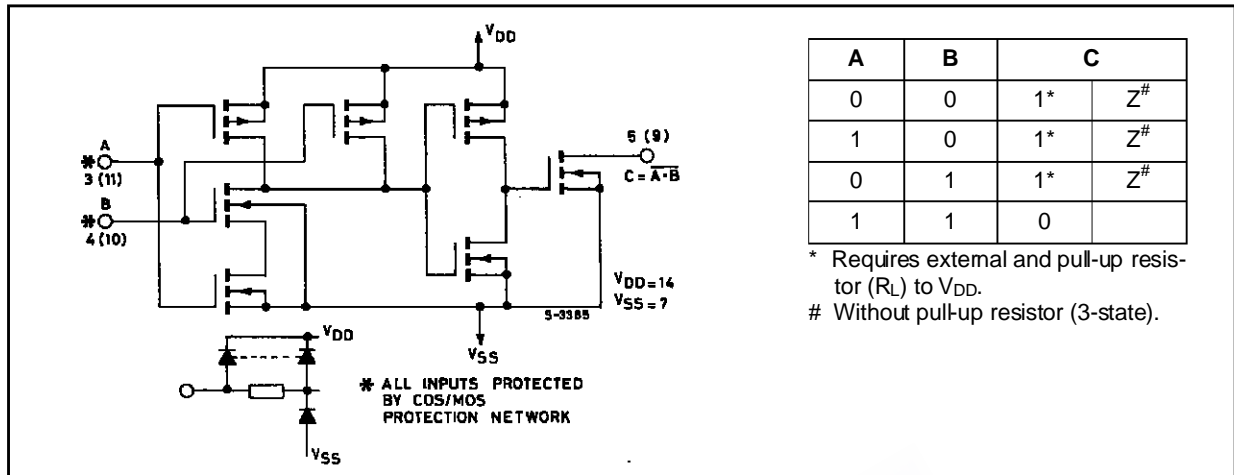

**STATIC ELECTRICAL CHARACTERISTICS** (over recommended operating conditions)

| Symbol             | Parameter          | Test Conditions       |                       |                          |                        | Value              |      |      |      |      |                     | Unit |      |
|--------------------|--------------------|-----------------------|-----------------------|--------------------------|------------------------|--------------------|------|------|------|------|---------------------|------|------|
|                    |                    | V <sub>I</sub><br>(V) | V <sub>O</sub><br>(V) | I <sub>o</sub>  <br>(μA) | V <sub>DD</sub><br>(V) | T <sub>Low</sub> * |      | 25°C |      |      | T <sub>High</sub> * |      |      |
|                    |                    |                       |                       |                          |                        | Min.               | Max. | Min. | Typ. | Max. | Min.                |      | Max. |
| I <sub>L</sub>     | Quiescent Current  | HCC Types             | 0/ 5                  |                          |                        | 5                  |      | 1    | 0.02 | 1    |                     | 30   | μA   |
|                    |                    |                       | 0/10                  |                          |                        | 10                 |      | 2    | 0.02 | 2    |                     | 60   |      |
|                    |                    |                       | 0/15                  |                          |                        | 15                 |      | 4    | 0.02 | 4    |                     | 120  |      |
|                    |                    | HCF Types             | 0/ 5                  |                          |                        | 5                  |      | 4    | 0.02 | 4    |                     | 30   |      |
|                    |                    |                       | 0/10                  |                          |                        | 10                 |      | 8    | 0.02 | 8    |                     | 60   |      |
|                    |                    |                       | 0/15                  |                          |                        | 15                 |      | 16   | 0.02 | 16   |                     | 120  |      |
|                    |                    |                       |                       |                          |                        |                    |      |      |      |      |                     |      |      |
| V <sub>IH</sub> ** | Input High Voltage |                       | 0.5/4.5               | < 1                      | 5                      | 3.5                |      | 3.5  |      |      | 3.5                 | V    |      |
|                    |                    |                       | 1/9                   | < 1                      | 10                     | 7                  |      | 7    |      |      | 7                   |      |      |
|                    |                    |                       | 1.5/13.5              | < 1                      | 15                     | 11                 |      | 11   |      |      | 11                  |      |      |
| V <sub>IL</sub> ** | Input Low Voltage  |                       | 4.5                   | < 1                      | 5                      |                    | 1.5  |      |      | 1.5  | 1.5                 | V    |      |
|                    |                    |                       | 9                     | < 1                      | 10                     |                    | 3    |      |      | 3    | 3                   |      |      |
|                    |                    |                       | 13.5                  | < 1                      | 15                     |                    | 4    |      |      | 4    | 4                   |      |      |

\* T<sub>Low</sub> = - 55°C for HCC device ; - 40°C for HCF device.  
 \* T<sub>High</sub> = + 125°C for HCC device ; + 85°C for HCF device.  
 The Noise Margin, full package temperature range, R<sub>L</sub> to V<sub>DD</sub> = 10kΩ : 1V min with V<sub>DD</sub> = 5V, 2V min with V<sub>DD</sub> = 10V, 2.5V min with V<sub>DD</sub> = 15V.  
 \*\* Measured with external pull-up resistor, R<sub>L</sub> = 10kΩ to V<sub>DD</sub>.  
 \*\*\* Forced output disabled.

## HCC/HCF40107B

### STATIC ELECTRICAL CHARACTERISTICS (continued)

| Symbol                                   | Parameter                      |                            | Test Conditions       |                       |                                |                        | Value              |               |      |         |         |                     | Unit |      |
|--|--------------------------------|----------------------------|-----------------------|-----------------------|--------------------------------|------------------------|--------------------|---------------|------|---------|---------|---------------------|------|------|
|  |                                |                            | V <sub>I</sub><br>(V) | V <sub>O</sub><br>(V) | I <sub>O</sub>  <br>( $\mu$ A) | V <sub>DD</sub><br>(V) | T <sub>Low</sub> * |               | 25°C |         |         | T <sub>High</sub> * |      |      |
|  |                                |                            |                       |                       |                                |                        | Min.               | Max.          | Min. | Typ.    | Max.    | Min.                |      | Max. |
| I <sub>OL</sub>                          | Output Sink Current            | HCC Types                  | 5                     | 0.4                   |                                | 5                      | 21                 |               | 16   | 32      |         | 12                  |      | mA   |
|  |                                |                            | 5                     | 1                     |                                | 5                      | 44                 |               | 30   | 68      |         | 25                  |      |      |
|  |                                |                            | 10                    | 0.5                   |                                | 10                     | 49                 |               | 37   | 74      |         | 28                  |      |      |
|  |                                |                            | 10                    | 1                     |                                | 10                     | 89                 |               | 68   | 136     |         | 51                  |      |      |
|  |                                |                            | 15                    | 0.5                   |                                | 15                     | 66                 |               | 50   | 100     |         | 38                  |      |      |
|  |                                | HCF Types                  | 5                     | 0.4                   |                                | 5                      | 17                 |               | 13.6 | 32      |         | 12                  |      |      |
|  |                                |                            | 5                     | 1                     |                                | 5                      | 35.7               |               | 25.5 | 68      |         | 22                  |      |      |
|  |                                |                            | 10                    | 0.5                   |                                | 10                     | 39.1               |               | 31.4 | 74      |         | 27                  |      |      |
|  |                                |                            | 10                    | 1                     |                                | 10                     | 72.2               |               | 57.8 | 136     |         | 51                  |      |      |
|  |                                |                            | 15                    | 0.5                   |                                | 15                     | 53.5               |               | 42.5 | 100     |         | 37                  |      |      |
| I <sub>OH</sub>                          | Output Drive Current           | No Internal Pull-up Device |                       |                       |                                |                        |                    |               |      |         |         | mA                  |      |      |
| I <sub>IH</sub> , I <sub>IL</sub>        | Input Leakage Current          | HCC Types                  | 0/18                  | Any Input             | 18                             | $\pm 0.1$              | $\pm 10^{-5}$      | $\pm 0.1$     |      |         | $\pm 1$ | $\mu$ A             |      |      |
|  |                                | HCF Types                  | 0/15                  |                       | 15                             | $\pm 0.3$              | $\pm 10^{-5}$      | $\pm 0.3$     |      | $\pm 1$ |         |                     |      |      |
| I <sub>OH</sub> , I <sub>OL</sub><br>*** | 3-State Output Leakage Current | HCC Types                  | 0/18                  | 18                    | 18                             | 2                      |                    | $\pm 10^{-4}$ | 2    |         | 20      | $\mu$ A             |      |      |
|  |                                | HCF Types                  | 0/15                  | 15                    | 15                             | 2                      |                    | $\pm 10^{-4}$ | 2    |         | 20      |                     |      |      |
| C <sub>I</sub>                           | Input Capacitance              | Any Input                  |                       |                       |                                |                        |                    | 5             | 7.5  |         |         | pF                  |      |      |
| C <sub>O</sub>                           | Output Capacitance             | Any Output                 |                       |                       |                                |                        |                    | 30            |      |         |         | pF                  |      |      |

\* T<sub>Low</sub> = -55°C for HCC device ; -40°C for HCF device.

\* T<sub>High</sub> = +125°C for HCC device ; +85°C for HCF device.

The Noise Margin, full package temperature range, R<sub>L</sub> to V<sub>DD</sub> = 10k $\Omega$  : 1V min with V<sub>DD</sub> = 5V, 2V min with V<sub>DD</sub> = 10V, 2.5V min with V<sub>DD</sub> = 15V.

\*\* Measured with external pull-up resistor, R<sub>L</sub> = 10k $\Omega$  to V<sub>DD</sub>.

\*\*\* Forced output disabled.

**DYNAMIC ELECTRICAL CHARACTERISTICS** ( $T_{amb} = 25^{\circ}\text{C}$ ,  $C_L = 50\text{pF}$ , typical temperature coefficient for all  $V_{DD}$  values is  $0.3\%/^{\circ}\text{C}$ , all input rise and fall time =  $20\text{ns}$ )

| Symbol                   | Parameter                             | Test Conditions     | Value        |      |      | Unit |      |
|--------------------------|---------------------------------------|---------------------|--------------|------|------|------|------|
|                          |                                       |                     | $V_{DD}$ (V) | Min. | Typ. |      | Max. |
| $t_{PHL}$ ,<br>$t_{PLH}$ | Propagation Delay Time<br>High to Low | $R_L^* = 120\Omega$ | 5            |      | 100  | 200  | ns   |
|                          |                                       |                     | 10           |      | 45   | 90   |      |
|                          |                                       |                     | 15           |      | 30   | 60   |      |
|                          | Low to High                           | $R_L^* = 120\Omega$ | 5            |      | 100  | 200  | ns   |
|                          |                                       |                     | 10           |      | 60   | 120  |      |
|                          |                                       |                     | 15           |      | 50   | 100  |      |
| $t_{THL}$ ,<br>$t_{TLH}$ | Transition Time<br>High to Low        | $R_L^* = 120\Omega$ | 5            |      | 50   | 100  | ns   |
|                          |                                       |                     | 10           |      | 20   | 40   |      |
|                          |                                       |                     | 15           |      | 10   | 20   |      |
|                          | Low to High                           | $R_L^* = 120\Omega$ | 5            |      | 50   | 100  | ns   |
|                          |                                       |                     | 10           |      | 35   | 70   |      |
|                          |                                       |                     | 15           |      | 25   | 50   |      |

\*  $R_L$  is external pull-up resistor to  $V_{DD}$ .

Output Low (sink) Current Characteristics.

Typical Propagation Delay Time vs. Load Capacitance.

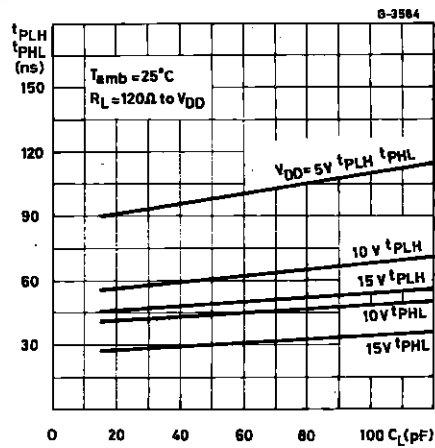
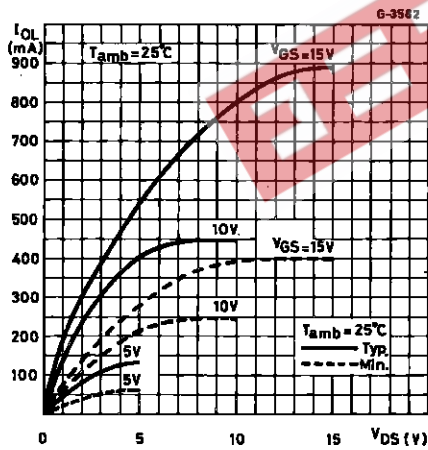

# HCC/HCF40107B

Typical Transition Time vs. Load Capacitance.

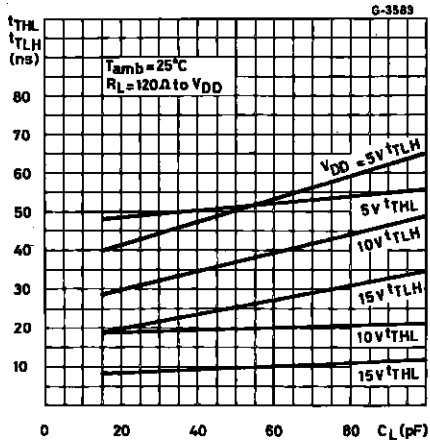

Typical Dynamic Power Dissipation vs. Input Frequency.

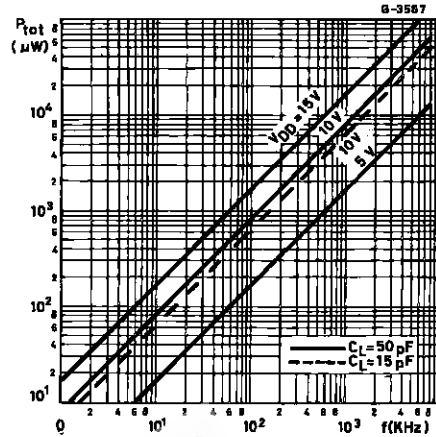

## TYPICAL APPLICATIONS

The bar on the output line of this logic diagram indicates that the output is open drain as is shown in the previous schematic diagram and truth table.

Logic Diagram of The HCC/HCF40107B nand Buffer.

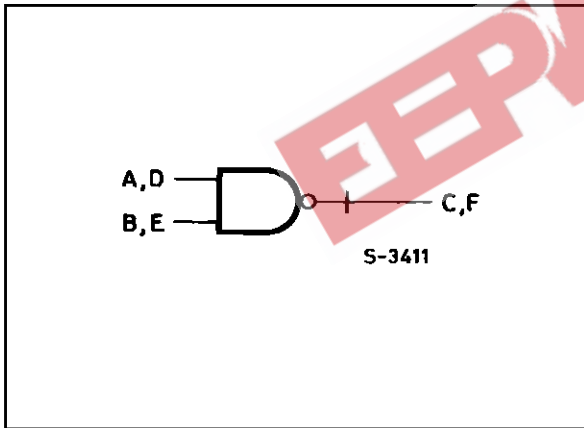

A 2.2-watt Incandescent Lamp-driver Circuit.

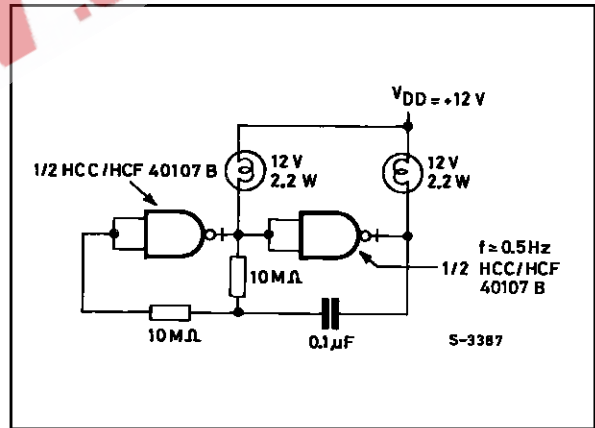

Interface of 40107B with Triac, with COS/MOS Component and Triac isolated.

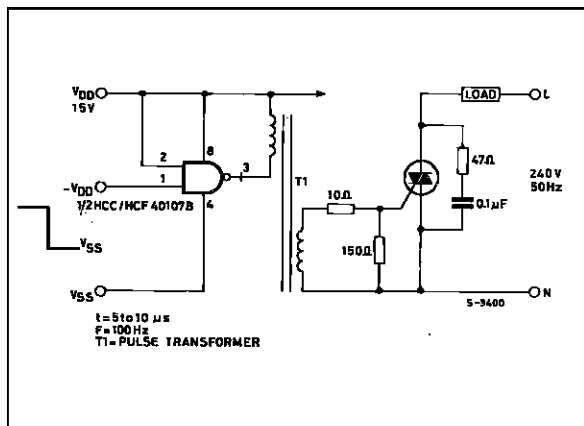

Solenoid Driver Circuit.

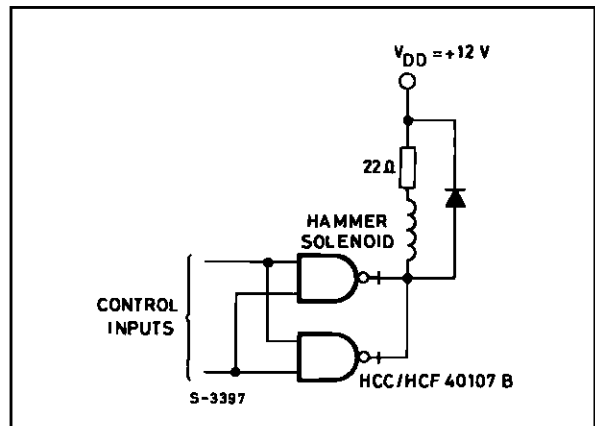

TYPICAL APPLICATIONS (continued)

Line-driver Circuit.

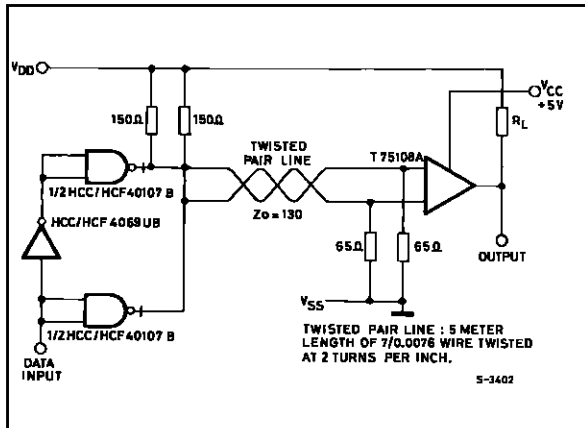

Direct Dc Driver Interface of 40107B with a Triac.

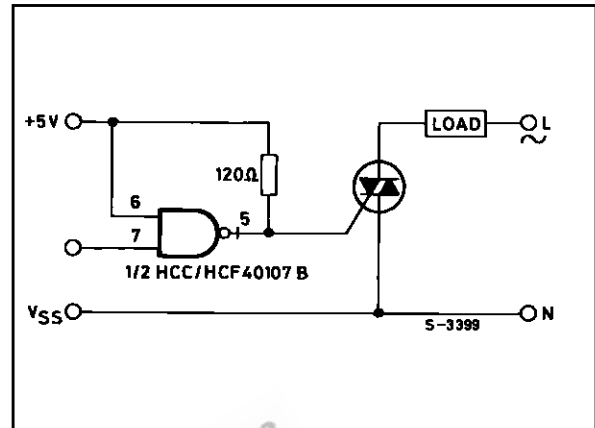

Multiplexed Led Circuit.

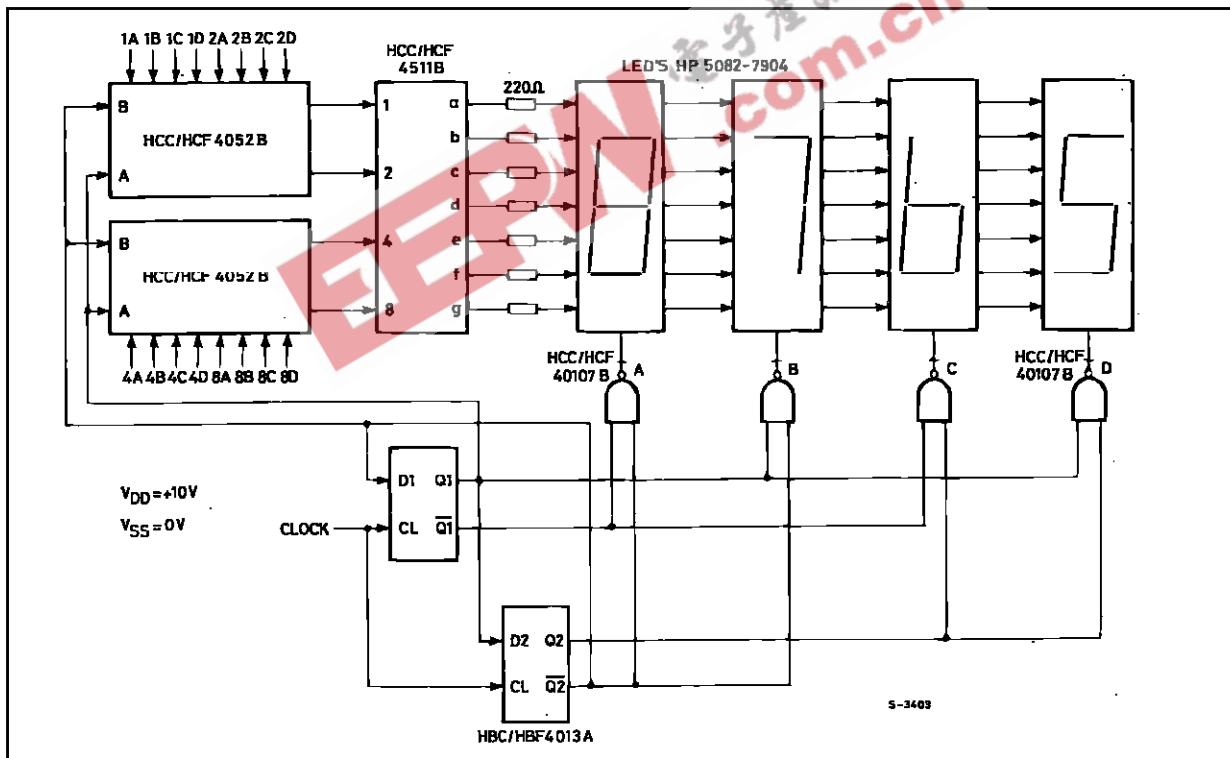

# HCC/HCF40107B

## TYPICAL APPLICATIONS (continued)

Motor-controller Circuit.

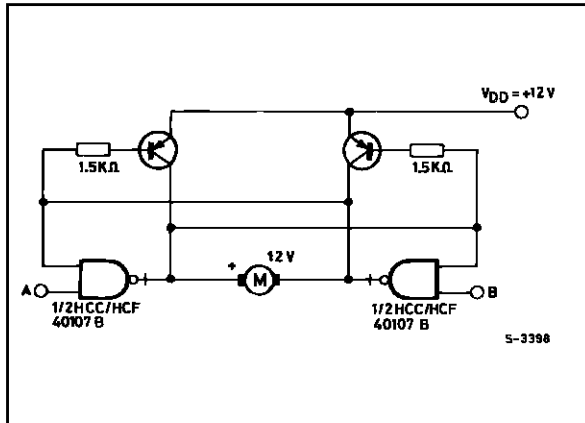

| A | B | Motor Function    |
|---|---|-------------------|
| 0 | 0 | OFF               |
| 1 | 0 | COUNTER CLOCKWISE |
| 1 | 1 | AS PREVIOUS STATE |
| 0 | 1 | CLOCKWISE         |
| 1 | 1 | AS PREVIOUS STATE |

Led Driver Circuit.

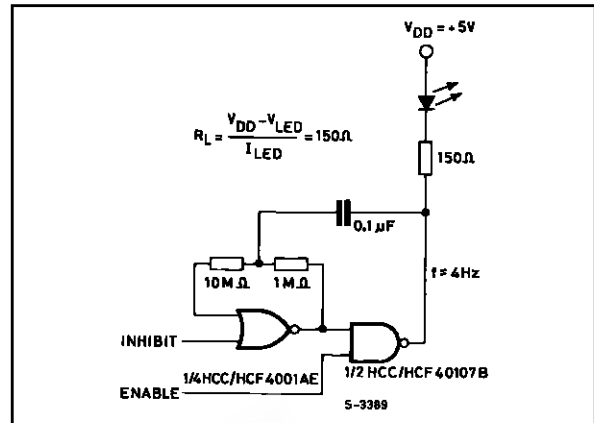

| INHIBIT | ENABLE | OUTPUT |
|---------|--------|--------|
| 0       | 0      | OFF    |
| 1       | 0      | OFF    |
| 0       | 1      | OFF    |
| 0       | 1      | ON     |

## TEST CIRCUITS

Quiescent Device Current.

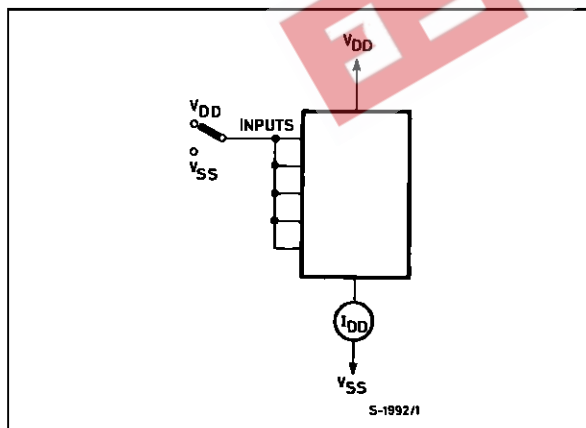

Input Voltage.

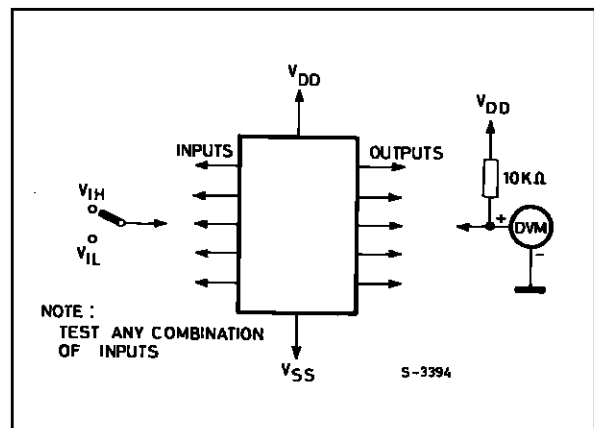



**TEST CIRCUITS** (continued)

Dynamic Power Dissipation.

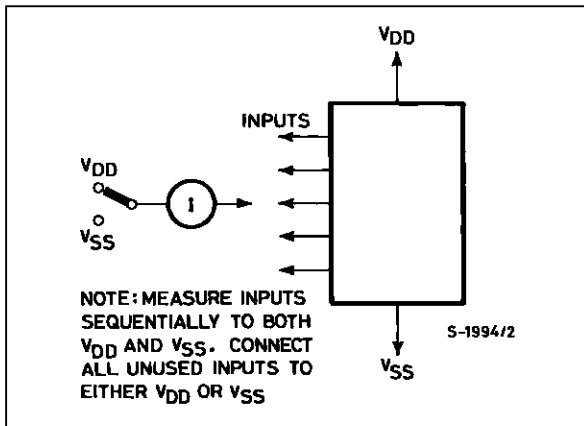

Dynamic Power Dissipation.

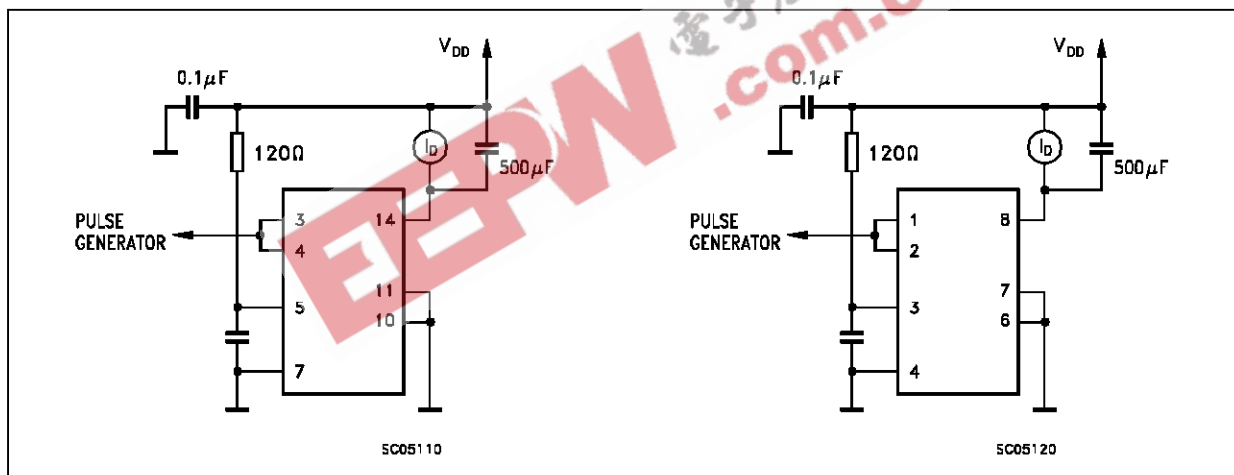

**Minidip (0.4) MECHANICAL DATA**

| DIM. | mm   |      |      | inch  |       |       |
|------|------|------|------|-------|-------|-------|
|      | MIN. | TYP. | MAX. | MIN.  | TYP.  | MAX.  |
| A    |      | 3.3  |      |       | 0.130 |       |
| a1   | 0.7  |      |      | 0.028 |       |       |
| B    | 1.39 |      | 1.65 | 0.055 |       | 0.065 |
| B1   | 0.91 |      | 1.04 | 0.036 |       | 0.041 |
| b    |      | 0.5  |      |       | 0.020 |       |
| b1   | 0.38 |      | 0.5  | 0.015 |       | 0.020 |
| D    |      |      | 9.8  |       |       | 0.386 |
| E    |      | 8.8  |      |       | 0.346 |       |
| e    |      | 2.54 |      |       | 0.100 |       |
| e3   |      | 7.62 |      |       | 0.300 |       |
| e4   |      | 7.62 |      |       | 0.300 |       |
| F    |      |      | 7.1  |       |       | 0.280 |
| I    |      |      | 4.8  |       |       | 0.189 |
| L    |      | 3.3  |      |       | 0.130 |       |
| Z    | 0.44 |      | 1.6  | 0.017 |       | 0.063 |

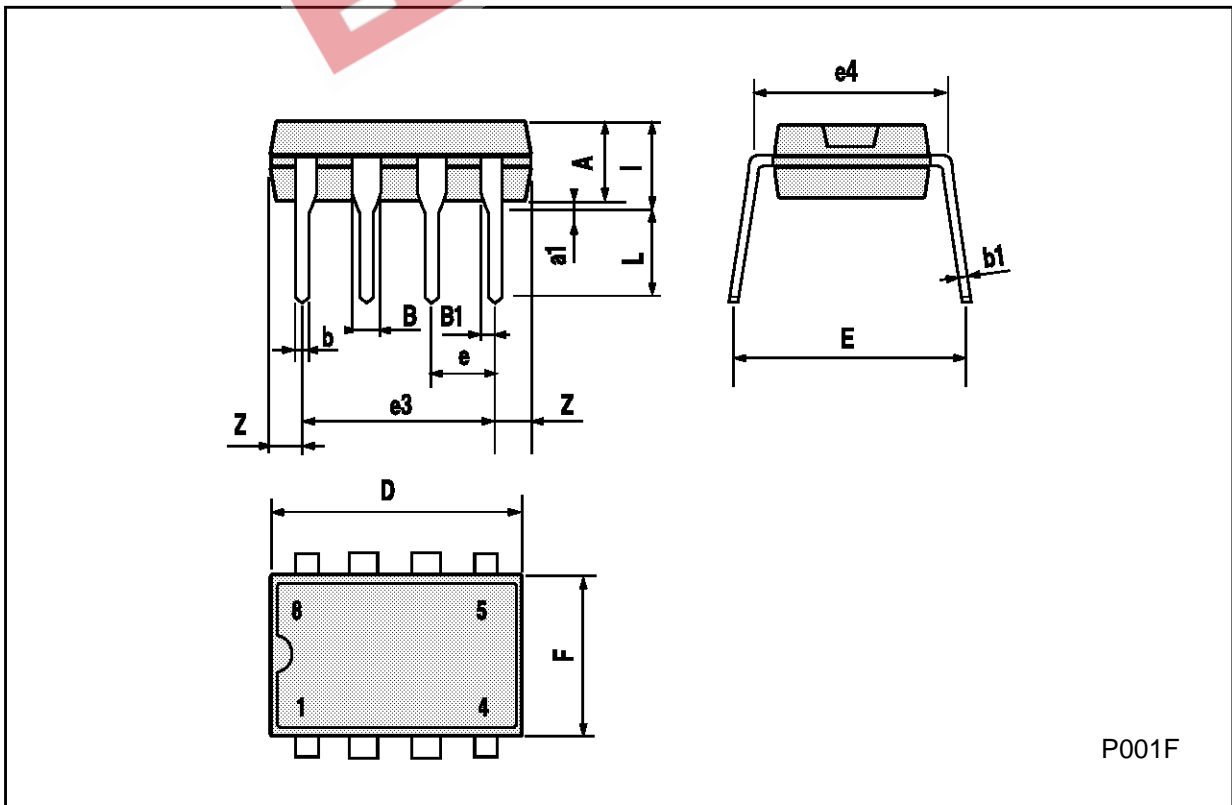

## Ceramic DIP14/1 MECHANICAL DATA

| DIM. | mm   |       |      | inch  |       |       |
|------|------|-------|------|-------|-------|-------|
|      | MIN. | TYP.  | MAX. | MIN.  | TYP.  | MAX.  |
| A    |      |       | 20   |       |       | 0.787 |
| B    |      |       | 7.0  |       |       | 0.276 |
| D    |      | 3.3   |      |       | 0.130 |       |
| E    | 0.38 |       |      | 0.015 |       |       |
| e3   |      | 15.24 |      |       | 0.600 |       |
| F    | 2.29 |       | 2.79 | 0.090 |       | 0.110 |
| G    | 0.4  |       | 0.55 | 0.016 |       | 0.022 |
| H    | 1.17 |       | 1.52 | 0.046 |       | 0.060 |
| L    | 0.22 |       | 0.31 | 0.009 |       | 0.012 |
| M    | 1.52 |       | 2.54 | 0.060 |       | 0.100 |
| N    |      |       | 10.3 |       |       | 0.406 |
| P    | 7.8  |       | 8.05 | 0.307 |       | 0.317 |
| Q    |      |       | 5.08 |       |       | 0.200 |

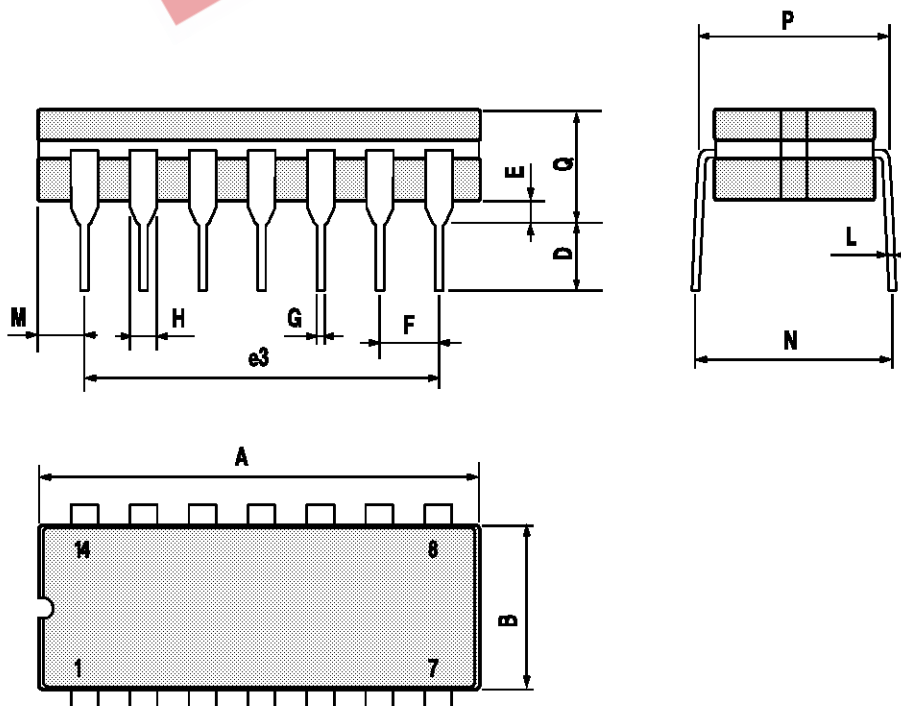

P053C

**SO8 MECHANICAL DATA**

| DIM. | mm         |      |      | inch  |       |       |
|------|------------|------|------|-------|-------|-------|
|      | MIN.       | TYP. | MAX. | MIN.  | TYP.  | MAX.  |
| A    |            |      | 1.75 |       |       | 0.068 |
| a1   | 0.1        |      | 0.25 | 0.003 |       | 0.009 |
| a2   |            |      | 1.65 |       |       | 0.064 |
| a3   | 0.65       |      | 0.85 | 0.025 |       | 0.033 |
| b    | 0.35       |      | 0.48 | 0.013 |       | 0.018 |
| b1   | 0.19       |      | 0.25 | 0.007 |       | 0.010 |
| C    | 0.25       |      | 0.5  | 0.010 |       | 0.019 |
| c1   | 45° (typ.) |      |      |       |       |       |
| D    | 4.8        |      | 5.0  | 0.188 |       | 0.196 |
| E    | 5.8        |      | 6.2  | 0.228 |       | 0.244 |
| e    |            | 1.27 |      |       | 0.050 |       |
| e3   |            | 3.81 |      |       | 0.150 |       |
| F    | 3.8        |      | 4.0  | 0.14  |       | 0.157 |
| L    | 0.4        |      | 1.27 | 0.015 |       | 0.050 |
| M    |            |      | 0.6  |       |       | 0.023 |
| S    | 8° (max.)  |      |      |       |       |       |

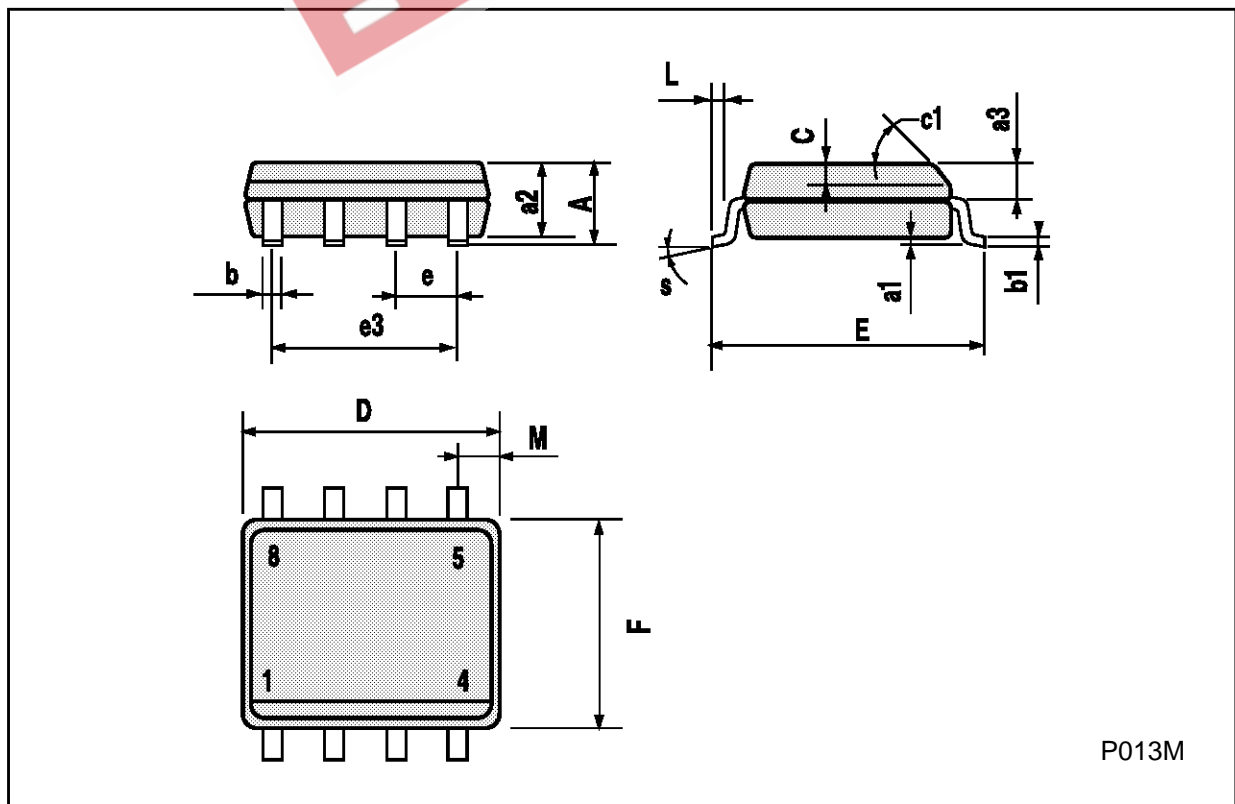

## PLCC20 MECHANICAL DATA

| DIM. | mm   |      |       | inch  |       |       |
|------|------|------|-------|-------|-------|-------|
|      | MIN. | TYP. | MAX.  | MIN.  | TYP.  | MAX.  |
| A    | 9.78 |      | 10.03 | 0.385 |       | 0.395 |
| B    | 8.89 |      | 9.04  | 0.350 |       | 0.356 |
| D    | 4.2  |      | 4.57  | 0.165 |       | 0.180 |
| d1   |      | 2.54 |       |       | 0.100 |       |
| d2   |      | 0.56 |       |       | 0.022 |       |
| E    | 7.37 |      | 8.38  | 0.290 |       | 0.330 |
| e    |      | 1.27 |       |       | 0.050 |       |
| e3   |      | 5.08 |       |       | 0.200 |       |
| F    |      | 0.38 |       |       | 0.015 |       |
| G    |      |      | 0.101 |       |       | 0.004 |
| M    |      | 1.27 |       |       | 0.050 |       |
| M1   |      | 1.14 |       |       | 0.045 |       |

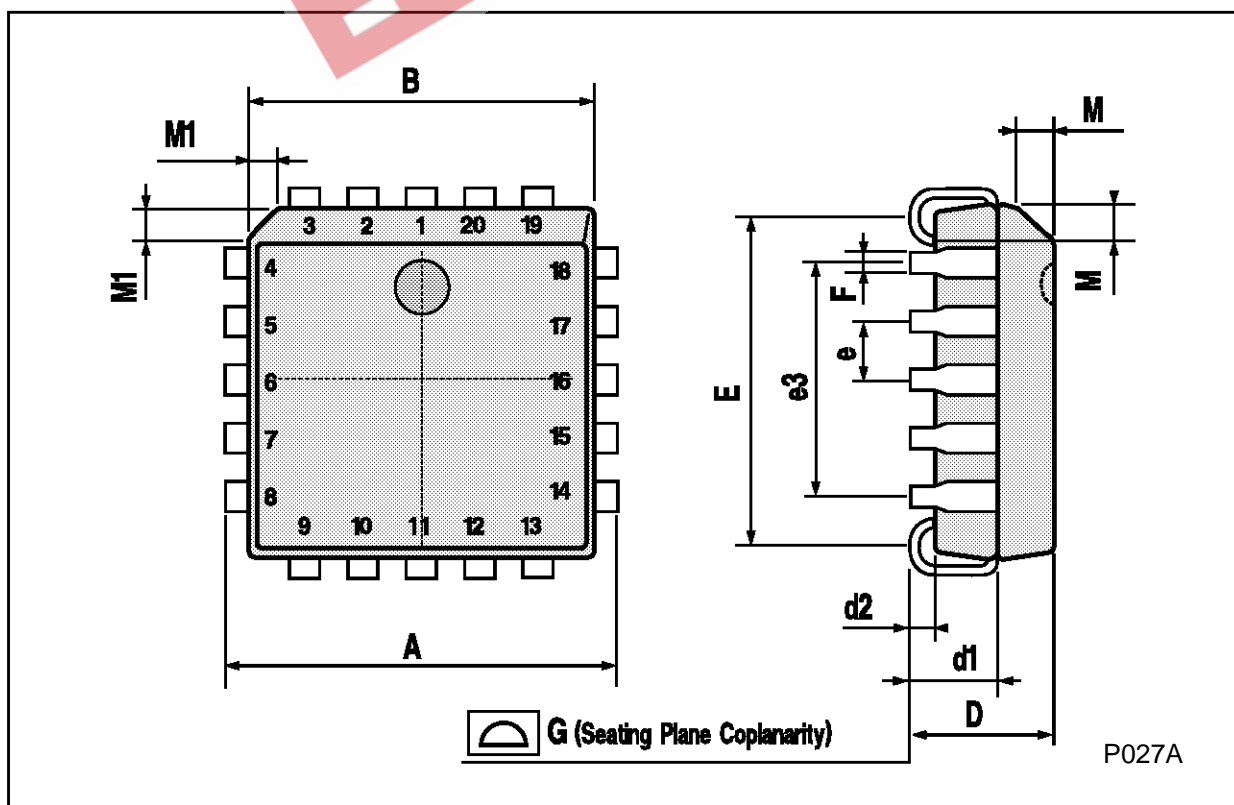

EEPW 电子產品世界  
.com.cn

Information furnished is believed to be accurate and reliable. However, SGS-THOMSON Microelectronics assumes no responsibility for the consequences of use of such information nor for any infringement of patents or other rights of third parties which may result from its use. No license is granted by implication or otherwise under any patent or patent rights of SGS-THOMSON Microelectronics. Specifications mentioned in this publication are subject to change without notice. This publication supersedes and replaces all information previously supplied. SGS-THOMSON Microelectronics products are not authorized for use as critical components in life support devices or systems without express written approval of SGS-THOMSON Microelectronics.

© 1994 SGS-THOMSON Microelectronics - All Rights Reserved

SGS-THOMSON Microelectronics GROUP OF COMPANIES  
Australia - Brazil - France - Germany - Hong Kong - Italy - Japan - Korea - Malaysia - Malta - Morocco - The Netherlands -  
Singapore - Spain - Sweden - Switzerland - Taiwan - Thailand - United Kingdom - U.S.A