



# FEMTOCLOCKS™ CRYSTAL-TO-3.3V, 2.5V LVPECL CLOCK GENERATOR

# ICS843021I-01

## General Description



The ICS843021I-01 is a Gigabit Ethernet Clock Generator and a member of the HiPerClocks™ family of high performance devices from IDT. The ICS843021I-01 uses a 25MHz crystal to synthesize 125MHz. The ICS843021I-01 has excellent phase jitter performance, over the 1.875MHz – 20MHz integration range. The ICS843021I-01 is packaged in a small 8-pin TSSOP, making it ideal for use in systems with limited board space.

## Features

- One differential 3.3V or 2.5V LVPECL output
- Crystal oscillator interface designed for 25MHz, 18pF parallel resonant crystal
- Output frequency range: 125MHz, using a 25MHz crystal
- VCO range: 490MHz – 640MHz
- RMS phase jitter @ 125MHz, using a 25MHz crystal (1.875MHz – 20MHz): 0.41ps (typical)
- Full 3.3V or 2.5V operating supply
- -40°C to 85°C ambient operating temperature
- Available in both standard (RoHS 5) and lead-free (RoHS 6) packages



## Block Diagram

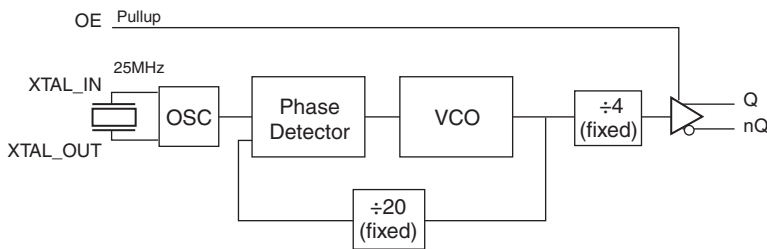

## Pin Assignment

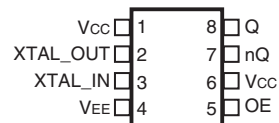

**ICS843021I-01**  
**8 Lead TSSOP**

**4.40mm x 3.0mm x 0.925mm package body**  
**G Package**  
**Top View**

**Table 1. Pin Descriptions**

Number	Name	Type		Description
1, 8	V <sub>CC</sub>	Power		Power supply pins.
2, 3	XTAL_OUT XTAL_IN	Input		Crystal oscillator interface. XTAL_IN is the input, XTAL_OUT is the output.
4	V <sub>EE</sub>	Power		Negative supply pin.
5	OE	Input	Pullup	Active high output enable. When logic HIGH, the outputs are enabled and active. When logic LOW, the outputs are disabled and are in a high impedance state. LVCMOS/LVTTL interface levels.
7, 8	nQ, Q	Output		Differential output pair. LVPECL interface levels.

NOTE: *Pullup* refers to internal input resistors. See Table 2, *Pin Characteristics*, for typical values.

**Table 2. Pin Characteristics**

Symbol	Parameter	Test Conditions	Minimum	Typical	Maximum	Units
C <sub>IN</sub>	Input Capacitance			4		pF
R <sub>PULLUP</sub>	Input Pullup Resistor			51		kΩ

## Absolute Maximum Ratings

NOTE: Stresses beyond those listed under *Absolute Maximum Ratings* may cause permanent damage to the device. These ratings are stress specifications only. Functional operation of product at these conditions or any conditions beyond those listed in the *DC Characteristics* or *AC Characteristics* is not implied. Exposure to absolute maximum rating conditions for extended periods may affect product reliability.

Item	Rating
Supply Voltage, $V_{CC}$	4.6V
Inputs, $V_I$	-0.5V to $V_{CC} + 0.5V$
Outputs, $I_O$ Continuous Current Surge Current	50mA 100mA
Package Thermal Impedance, $\theta_{JA}$	129.5°C/W (0 mps)
Storage Temperature, $T_{STG}$	-65°C to 150°C

## DC Electrical Characteristics

**Table 3A. Power Supply DC Characteristics,  $V_{CC} = 3.3V \pm 5\%$ ,  $V_{EE} = 0V$ ,  $T_A = -40^\circ C$  to  $85^\circ C$**

Symbol	Parameter	Test Conditions	Minimum	Typical	Maximum	Units
$V_{CC}$	Positive Supply Voltage		3.135	3.3	3.465	V
$I_{EE}$	Power Supply Current				64	mA

**Table 3B. Power Supply DC Characteristics,  $V_{CC} = 2.5V \pm 5\%$ ,  $V_{EE} = 0V$ ,  $T_A = -40^\circ C$  to  $85^\circ C$**

Symbol	Parameter	Test Conditions	Minimum	Typical	Maximum	Units
$V_{CC}$	Positive Supply Voltage		2.375	2.5	2.625	V
$I_{EE}$	Power Supply Current				62	mA

**Table 3C. LVCMOS/LVTTL DC Characteristics,  $V_{CC} = 3.3V \pm 5\%$  or  $2.5V \pm 5\%$ ,  $V_{EE} = 0V$ ,  $T_A = 0^\circ C$  to  $70^\circ C$**

Symbol	Parameter	Test Conditions	Minimum	Typical	Maximum	Units
$V_{IH}$	Input High Voltage	$V_{CC} = 3.3V$	2		$V_{CC} + 0.3$	V
		$V_{CC} = 2.5V$	1.7		$V_{CC} + 0.3$	V
$V_{IL}$	Input Low Voltage	$V_{CC} = 3.3V$	-0.3		0.8	V
		$V_{CC} = 2.5V$	-0.3		0.7	
$I_{IH}$	Input High Current	$V_{CC} = V_{IN} = 3.465$ or $2.625V$			5	$\mu A$
$I_{IL}$	Input Low Current	$V_{CC} = 3.465V$ or $2.625V$ , $V_{IN} = 0V$	-150			$\mu A$

**Table 3D. LVPECL DC Characteristics,  $V_{CC} = 3.3V \pm 5\%$ ,  $V_{EE} = 0V$ ,  $T_A = -40^\circ C$  to  $85^\circ C$** 

Symbol	Parameter	Test Conditions	Minimum	Typical	Maximum	Units
$V_{OH}$	Output High Current; NOTE 1		$V_{CC} - 1.4$		$V_{CC} - 0.9$	$\mu A$
$V_{OL}$	Output Low Current; NOTE 1		$V_{CC} - 2.0$		$V_{CC} - 1.7$	$\mu A$
$V_{SWING}$	Peak-to-Peak Output Voltage Swing		0.6		1.0	V

NOTE 1: Outputs termination with  $50\Omega$  to  $V_{CC} - 2V$ .**Table 3E. LVPECL DC Characteristics,  $V_{CC} = 2.5V \pm 5\%$ ,  $V_{EE} = 0V$ ,  $T_A = -40^\circ C$  to  $85^\circ C$** 

Symbol	Parameter	Test Conditions	Minimum	Typical	Maximum	Units
$V_{OH}$	Output High Current; NOTE 1		$V_{CC} - 1.4$		$V_{CC} - 0.9$	$\mu A$
$V_{OL}$	Output Low Current; NOTE 1		$V_{CC} - 2.0$		$V_{CC} - 1.5$	$\mu A$
$V_{SWING}$	Peak-to-Peak Output Voltage Swing		0.4		1.0	V

NOTE 1: Outputs termination with  $50\Omega$  to  $V_{CC} - 2V$ .**Table 4. Crystal Characteristics**

Parameter	Test Conditions	Minimum	Typical	Maximum	Units
Mode of Oscillation		Fundamental			
Frequency; NOTE 1			25		MHz
Equivalent Series Resistance (ESR)				90	$\Omega$
Shunt Capacitance				7	pF
Drive Level				300	$\mu W$

## AC Electrical Characteristics

**Table 5A. AC Characteristics,  $V_{CC} = 3.3V \pm 5\%$ ,  $V_{EE} = 0V$ ,  $T_A = -40^\circ C$  to  $85^\circ C$** 

Parameter	Symbol	Test Conditions	Minimum	Typical	Maximum	Units
Output Frequency	$f_{OUT}$		122.5	125	160	MHz
RMS Phase Jitter, Random; NOTE 1	$f_{jit}(\emptyset)$	125MHz, ( Integration Range: 1.875MHz – 20MHz)		0.41		ps
Output Rise/Fall Time	$t_R / t_F$	20% to 80%	250		600	ps
Output Duty Cycle	odc		49		51	%

NOTE 1: Please refer to Phase Noise Plot.

**Table 5B. AC Characteristics,  $V_{CC} = 2.5V \pm 5\%$ ,  $V_{EE} = 0V$ ,  $T_A = -40^\circ C$  to  $85^\circ C$** 

Parameter	Symbol	Test Conditions	Minimum	Typical	Maximum	Units
Output Frequency	$f_{OUT}$		122.5	125	160	MHz
RMS Phase Jitter, Random; NOTE 1	$f_{jit}(\emptyset)$	125MHz, ( Integration Range: 1.875MHz – 20MHz)		0.42		ps
Output Rise/Fall Time	$t_R / t_F$	20% to 80%	250		600	ps
Output Duty Cycle	odc		49		51	%

NOTE 1: Please refer to Phase Noise Plot.

## Typical Phase Noise at 125MHz (3.3V or 2.5V)

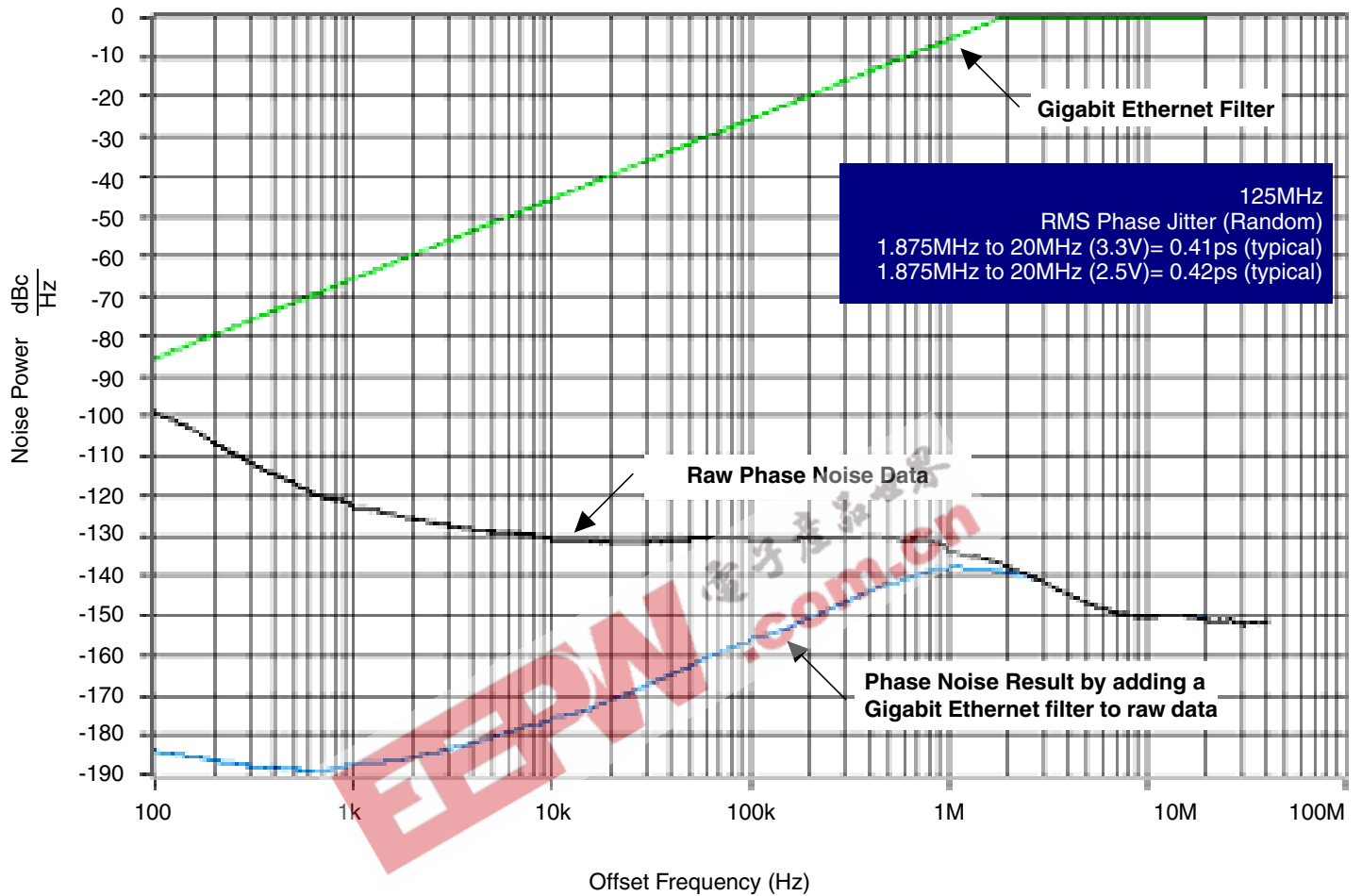

### Parameter Measurement Information

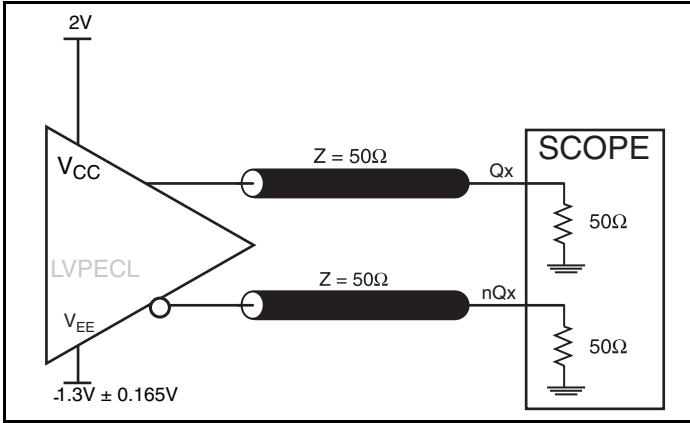

3.3V LVPECL Output Load AC Test Circuit

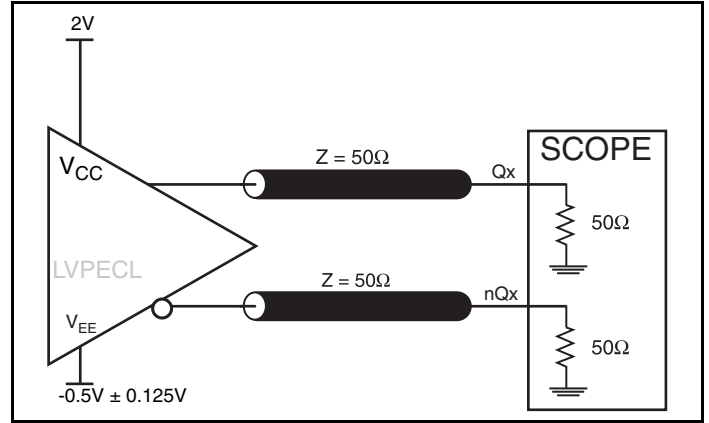

2.5V LVPECL Output Load AC Test Circuit

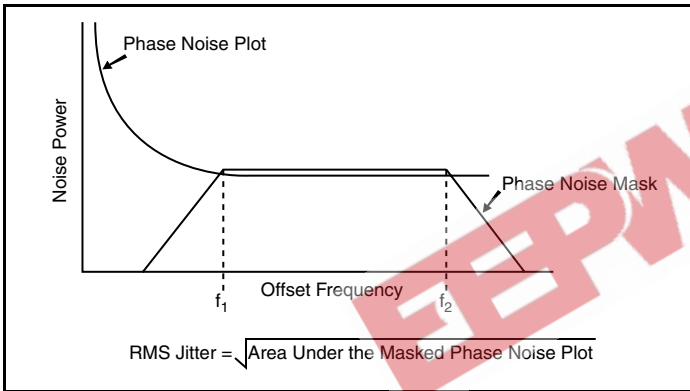

RMS Phase Jitter

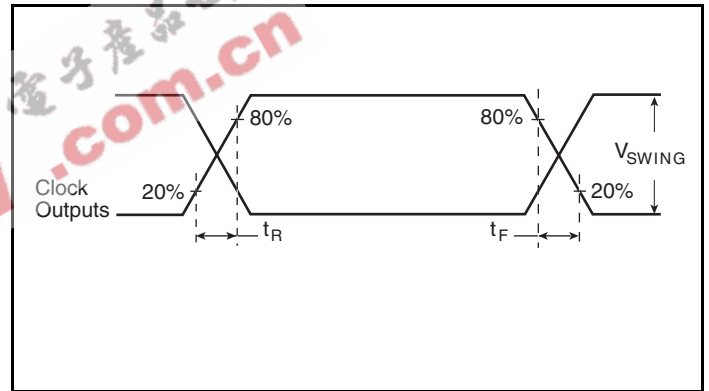

Output Rise/Fall Time

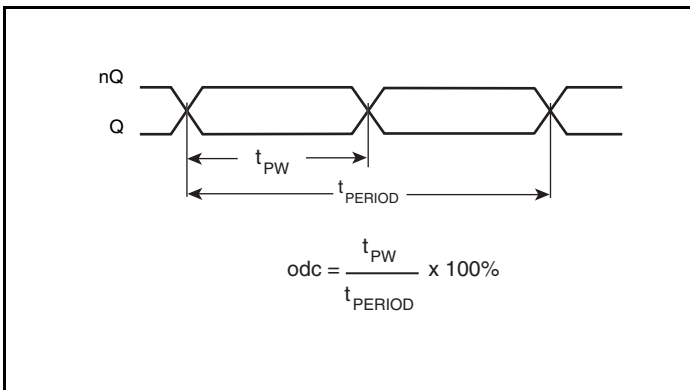

Output Duty Cycle/Pulse Width/Period

## Application Information

### Crystal Input Interface

The ICS843021I-01 has been characterized with 18pF parallel resonant crystals. The capacitor values, C1 and C2, shown in *Figure 1* below were determined using a 25MHz, 18pF parallel resonant crystal and were chosen to minimize the ppm error. The optimum C1 and C2 values can be slightly adjusted for different board layouts.

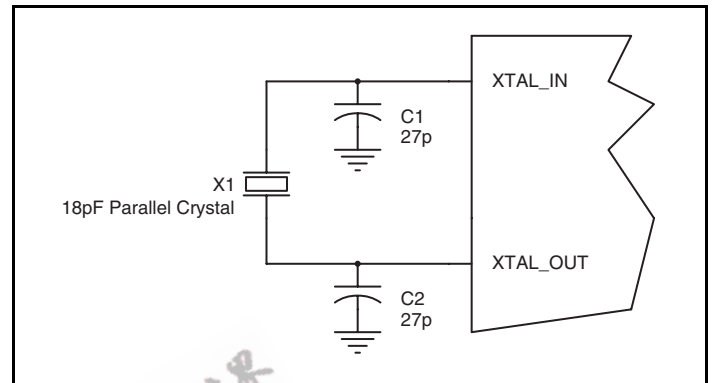

Figure 1. Crystal Input Interface

### LVC MOS to XTAL Interface

The XTAL\_IN input can accept a single-ended LVC MOS signal through an AC coupling capacitor. A general interface diagram is shown in *Figure 2*. The XTAL\_OUT pin can be left floating. The input edge rate can be as slow as 10ns. For LVC MOS inputs, it is recommended that the amplitude be reduced from full swing to half swing in order to prevent signal interference with the power rail and to reduce noise. This configuration requires that the output

impedance of the driver ( $R_o$ ) plus the series resistance ( $R_s$ ) equals the transmission line impedance. In addition, matched termination at the crystal input will attenuate the signal in half. This can be done in one of two ways. First, R1 and R2 in parallel should equal the transmission line impedance. For most 50Ω applications, R1 and R2 can be 100Ω. This can also be accomplished by removing R1 and making R2 50Ω.

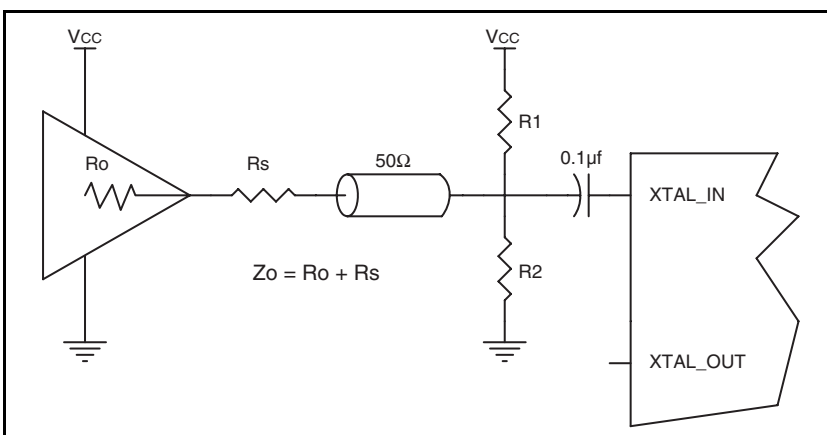

Figure 2. General Diagram for LVC MOS Driver to XTAL Input Interface

## Termination for 3.3V LVPECL Outputs

The clock layout topology shown below is a typical termination for LVPECL outputs. The two different layouts mentioned are recommended only as guidelines.

FOUT and nFOUT are low impedance follower outputs that generate ECL/LVPECL compatible outputs. Therefore, terminating resistors (DC current path to ground) or current sources must be used for functionality. These outputs are designed to drive 50Ω

transmission lines. Matched impedance techniques should be used to maximize operating frequency and minimize signal distortion. *Figures 3A and 3B* show two different layouts which are recommended only as guidelines. Other suitable clock layouts may exist and it would be recommended that the board designers simulate to guarantee compatibility across all printed circuit and clock component process variations.

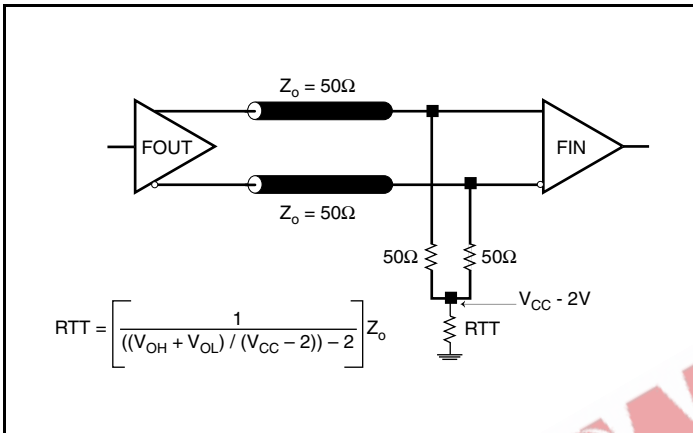

Figure 3A. 3.3V LVPECL Output Termination

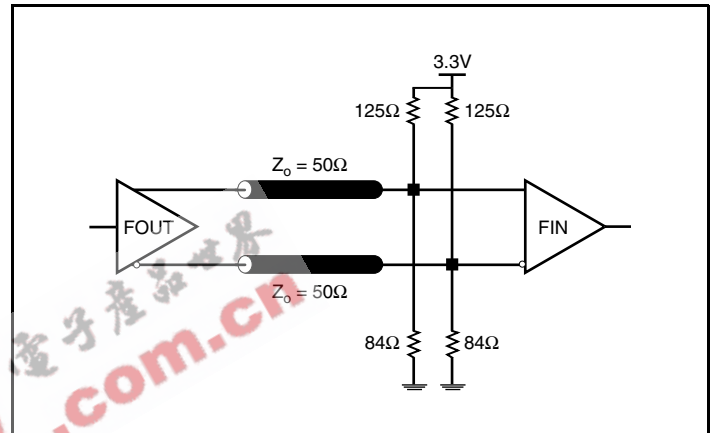

Figure 3B. 3.3V LVPECL Output Termination



## Termination for 2.5V LVPECL Outputs

Figure 4A and Figure 5B show examples of termination for 2.5V LVPECL driver. These terminations are equivalent to terminating 50Ω to  $V_{CC} - 2V$ . For  $V_{CC} = 2.5V$ , the  $V_{CC} - 2V$  is very close to

ground level. The R3 in Figure 4B can be eliminated and the termination is shown in Figure 4C.

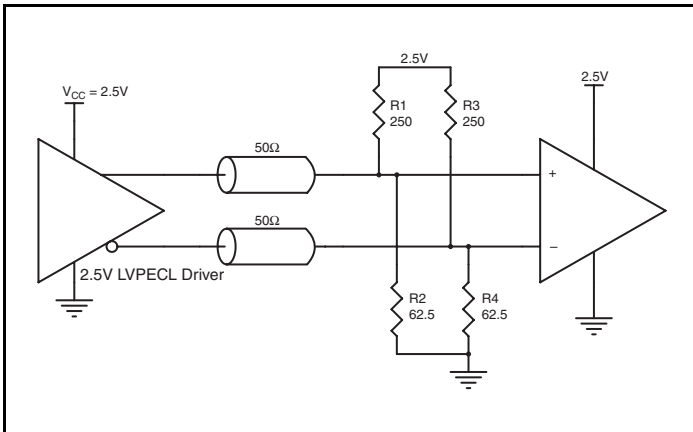

Figure 4A. 2.5V LVPECL Driver Termination Example

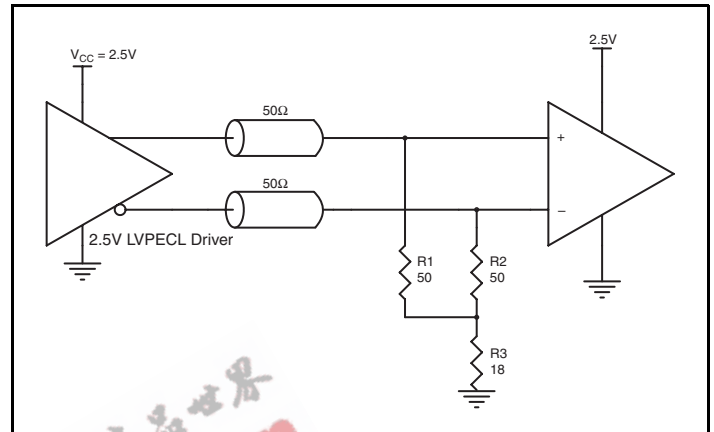

Figure 4B. 2.5V LVPECL Driver Termination Example

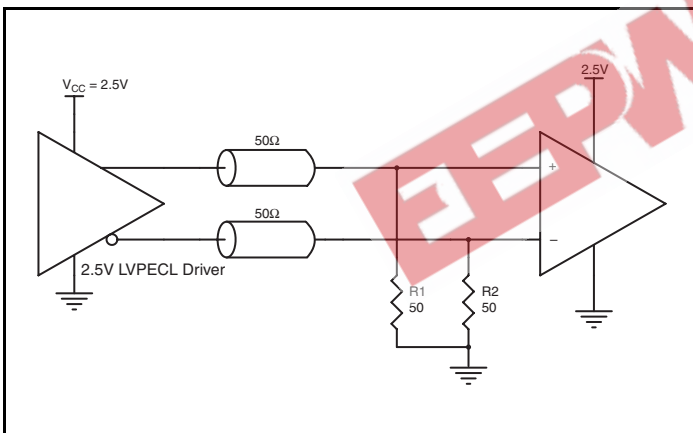

Figure 4C. 2.5V LVPECL Driver Termination Example

## Schematic Example

Figure 5 shows an example of ICS843021I-01 application schematic. In this example, the device is operated at  $V_{CC} = 3.3V$ . The decoupling capacitor should be located as close as possible to the power pin. The input is driven by a 25MHz quartz crystal. For

the LVPECL output drivers, only two termination examples are shown in this schematic. Additional termination approaches are shown in the LVPECL Termination Application Note.

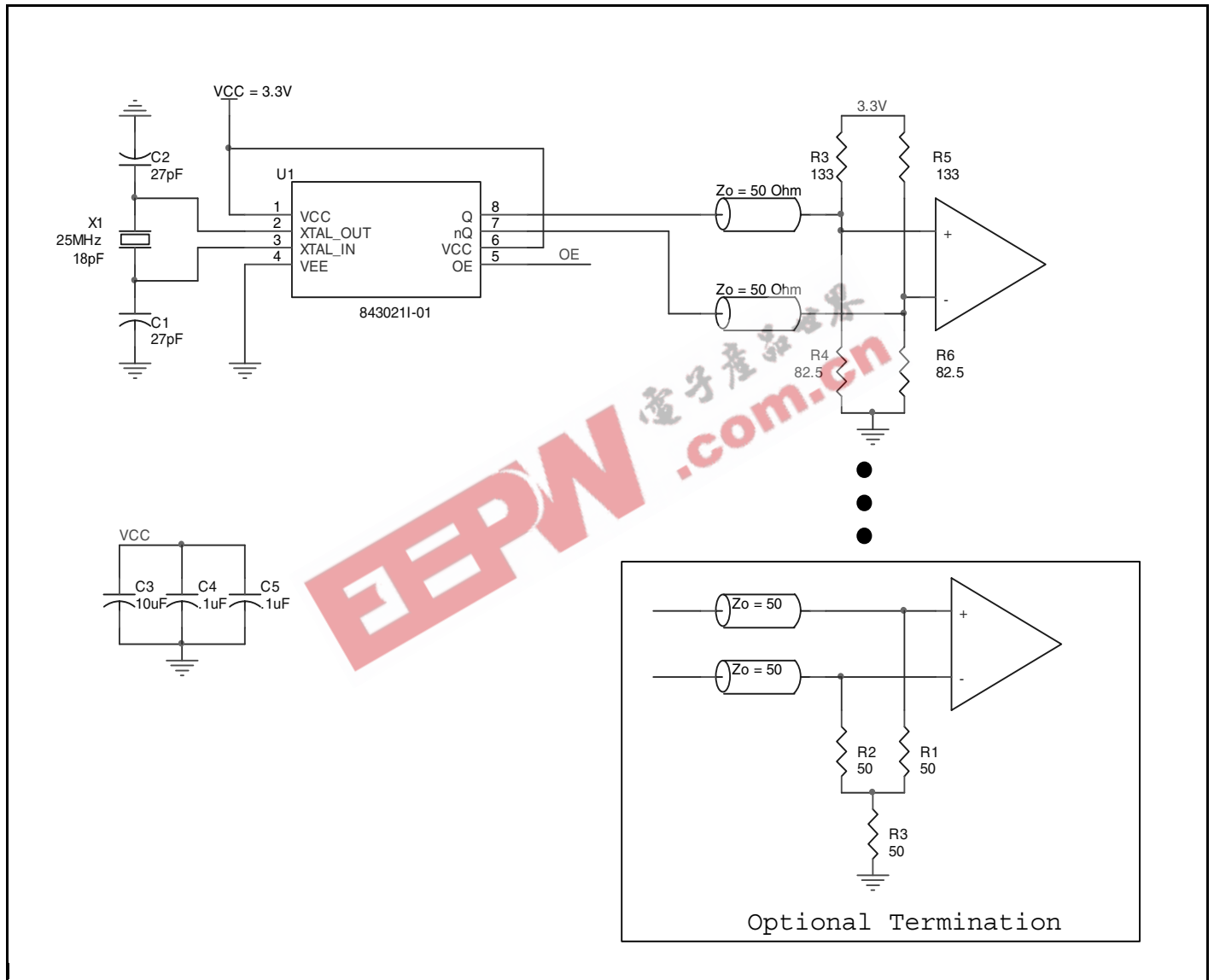

Figure 5. ICS843021I-01 Schematic Example

## Power Considerations

This section provides information on power dissipation and junction temperature for the ICS843021I-01. Equations and example calculations are also provided.

### 1. Power Dissipation.

The total power dissipation for the ICS843021I-01 is the sum of the core power plus the power dissipated in the load(s). The following is the power dissipation for  $V_{CC} = 3.3V + 5\% = 3.465V$ , which gives worst case results.

NOTE: Please refer to Section 3 for details on calculating power dissipated in the load.

- Power (core)<sub>MAX</sub> =  $V_{CC\_MAX} * I_{EE\_MAX} = 3.465V * 64mA = 221.76mW$
- Power (outputs)<sub>MAX</sub> = **30mW/Loaded Output pair**

**Total Power<sub>MAX</sub>** (3.3V, with all outputs switching) =  $221.76mW + 30mW = 251.76mW$

### 2. Junction Temperature.

Junction temperature,  $T_j$ , is the temperature at the junction of the bond wire and bond pad and directly affects the reliability of the device. The maximum recommended junction temperature for HiPerClockS devices is 125°C.

The equation for  $T_j$  is as follows:  $T_j = \theta_{JA} * Pd\_total + T_A$

$T_j$  = Junction Temperature

$\theta_{JA}$  = Junction-to-Ambient Thermal Resistance

$Pd\_total$  = Total Device Power Dissipation (example calculation is in section 1 above)

$T_A$  = Ambient Temperature

In order to calculate junction temperature, the appropriate junction-to-ambient thermal resistance  $\theta_{JA}$  must be used. Assuming no air flow and a multi-layer board, the appropriate value is 129.5°C/W per Table 6 below.

Therefore,  $T_j$  for an ambient temperature of 85°C with all outputs switching is:

$85°C + 0.252W * 90.5°C/W = 117.6°C$ . This is below the limit of 125°C.

This calculation is only an example.  $T_j$  will obviously vary depending on the number of loaded outputs, supply voltage, air flow and the type of board (single layer or multi-layer).

**Table 6. Thermal Resistance  $\theta_{JA}$  for 8 Lead TSSOP, Forced Convection**

Meters per Second	$\theta_{JA}$ by Velocity		
	0	1	2.5
Multi-Layer PCB, JEDEC Standard Test Boards	129.5°C/W	125.5°C/W	123.5°C/W

### 3. Calculations and Equations.

The purpose of this section is to derive the power dissipated into the load.

LVPECL output driver circuit and termination are shown in *Figure 6*.

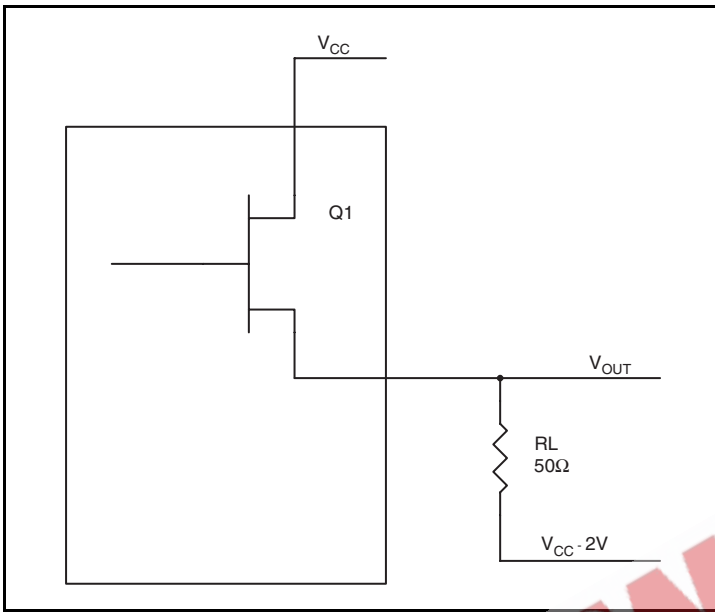

**Figure 6. LVPECL Driver Circuit and Termination**

To calculate worst case power dissipation into the load, use the following equations which assume a 50Ω load, and a termination voltage of  $V_{CC} - 2V$ .

- For logic high,  $V_{OUT} = V_{OH\_MAX} = V_{CC\_MAX} - 0.9V$   
 $(V_{CC\_MAX} - V_{OH\_MAX}) = 0.9V$
- For logic low,  $V_{OUT} = V_{OL\_MAX} = V_{CC\_MAX} - 1.7V$   
 $(V_{CC\_MAX} - V_{OL\_MAX}) = 1.7V$

$Pd\_H$  is power dissipation when the output drives high.

$Pd\_L$  is the power dissipation when the output drives low.

$$Pd\_H = [(V_{OH\_MAX} - (V_{CC\_MAX} - 2V))/R_L] * (V_{CC\_MAX} - V_{OH\_MAX}) = [(2V - (V_{CC\_MAX} - V_{OH\_MAX}))/R_L] * (V_{CC\_MAX} - V_{OH\_MAX}) = [(2V - 0.9V)/50\Omega] * 0.9V = \mathbf{19.8mW}$$

$$Pd\_L = [(V_{OL\_MAX} - (V_{CC\_MAX} - 2V))/R_L] * (V_{CC\_MAX} - V_{OL\_MAX}) = [(2V - (V_{CC\_MAX} - V_{OL\_MAX}))/R_L] * (V_{CC\_MAX} - V_{OL\_MAX}) = [(2V - 1.7V)/50\Omega] * 1.7V = \mathbf{10.2mW}$$

Total Power Dissipation per output pair =  $Pd\_H + Pd\_L = \mathbf{30mW}$

## Reliability Information

Table 7.  $\theta_{JA}$  vs. Air Flow Table for a 8 Lead TSSOP

$\theta_{JA}$ vs. Air Flow			
Meters per Second	0	1	2.5
Multi-Layer PCB, JEDEC Standard Test Boards	129.5°C/W	125.5°C/W	123.5°C/W

## Transistor Count

The transistor count for ICS843021I-01 is: 1765

## Package Outline and Package Dimension

Package Outline - G Suffix for 8 Lead TSSOP

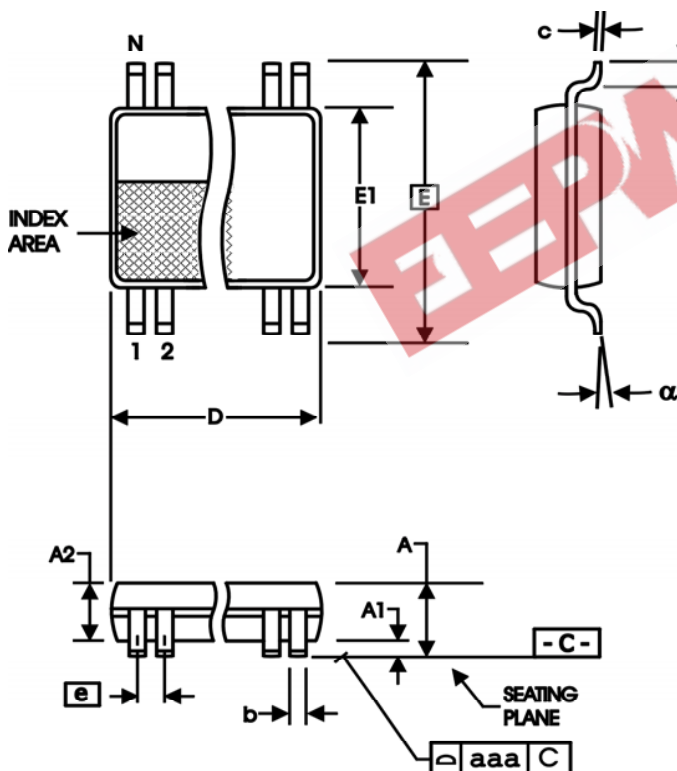

Table 8. Package Dimensions

All Dimensions in Millimeters		
Symbol	Minimum	Maximum
N	8	
A		1.20
A1	0.05	0.15
A2	0.80	1.05
b	0.19	0.30
c	0.09	0.20
D	2.90	3.10
E	6.40 Basic	
E1	4.30	4.50
e	0.65 Basic	
L	0.45	0.75
$\alpha$	0°	8°
aaa		0.10

Reference Document: JEDEC Publication 95, MO-153

## Ordering Information

Table 9. Ordering Information

Part/Order Number	Marking	Package	Shipping Packaging	Temperature
ICS843021AGI-01	1AI01	8 Lead TSSOP	Tube	0°C to 70°C
ICS843021AGI-01T	1AI01	8 Lead TSSOP	2500 Tape & Reel	0°C to 70°C
ICS843021AGI-01LF	AI01L	"Lead-Free" 8 Lead TSSOP	Tube	0°C to 70°C
ICS843021AGI-01LFT	AI01L	"Lead-Free" 8 Lead TSSOP	2500 Tape & Reel	0°C to 70°C

NOTE: Parts that are ordered with an "LF" suffix to the part number are the Pb-Free configuration and are RoHS compliant.

EEPW 电子产品世界  
.com.cn

While the information presented herein has been checked for both accuracy and reliability, Integrated Device Technology (IDT) assumes no responsibility for either its use or for the infringement of any patents or other rights of third parties, which would result from its use. No other circuits, patents, or licenses are implied. This product is intended for use in normal commercial and industrial applications. Any other applications, such as those requiring high reliability or other extraordinary environmental requirements are not recommended without additional processing by IDT. IDT reserves the right to change any circuitry or specifications without notice. IDT does not authorize or warrant any IDT product for use in life support devices or critical medical instruments.

ICS843021I-01

FEMTOCLOCKS™ CRYSTAL-TO-3.3V, 2.5V LVPECL CLOCK GENERATOR

EEPW 电子产品世界  
.com.cn

Innovate with IDT and accelerate your future networks. Contact:

[www.IDT.com](http://www.IDT.com)

**For Sales**

800-345-7015  
408-284-8200  
Fax: 408-284-2775

**For Tech Support**

netcom@idt.com  
480-763-2056

**Corporate Headquarters**

Integrated Device Technology, Inc.  
6024 Silver Creek Valley Road  
San Jose, CA 95138  
United States  
800 345 7015  
+408 284 8200 (outside U.S.)

**Asia Pacific and Japan**

Integrated Device Technology  
Singapore (1997) Pte. Ltd.  
Reg. No. 199707558G  
435 Orchard Road  
#20-03 Wisma Atria  
Singapore 238877  
+65 6 887 5505

**Europe**

IDT Europe, Limited  
321 Kingston Road  
Leatherhead, Surrey  
England  
+44 (0) 1372 363 339  
Fax: +44 (0) 1372 378851

