



# ST16C32245

## 14 BIT DUAL SUPPLY BUS TRANSCEIVER LEVEL TRANSLATOR, A SIDE SERIES RESISTOR, 2 BIT I<sup>2</sup>C LINES

PRELIMINARY DATA

- HIGH SPEED:  $t_{PD} = 4.4ns$  (MAX.) at  $T_A=85^\circ C$   
 $V_{CCA} = 3.0V$   $V_{CCB} = 2.3V$
- LOW POWER DISSIPATION:  
 $I_{CCA} = I_{CCB} = 20\mu A$  (MAX.) at  $T_A=85^\circ C$
- SYMMETRICAL OUTPUT IMPEDANCE:  
 $|I_{OHA}| = I_{OLA} = 8mA$  MIN at  
 $V_{CCA} = 3.0V$   $V_{CCB} = 1.65V$  or  $2.3V$   
 $|I_{OHB}| = I_{OLB} = 6mA$  MIN at  
 $V_{CCB} = 1.65V$   $V_{CCA} = 3V$
- BALANCED PROPAG. DELAYS:  $t_{PLH} \cong t_{PHL}$
- POWER DOWN PROTECTION ON I/O
- 26Ω SERIES RESISTOR ON A SIDE OUTPUTS
- OPERATING VOLTAGE RANGE:  
 $V_{CCA}(OPR)=2.3V$  to  $3.6V$  (1.2V Data Retent)  
 $V_{CCB}(OPR)=1.65V$  to  $2.7V$  (1.2V Data Retent)
- FAST I<sup>2</sup>C LINES 1.8V/2.8V LEVEL TRANSLATOR: 400KHz GUARANTEED DATA RATE AT  $C_L = 15pF$
- BUS HOLD PROVIDED ON DATA INPUT BOTH SIDE
- LATCH-UP PERFORMANCE EXCEEDS 500mA (JESD 17)
- ESD PERFORMANCE:  
HBM > 2000V (MIL STD 883 method 3015);  
MM > 200V

### DESCRIPTION

The ST16C32245 is a dual supply low voltage CMOS 14-BIT BUS TRANSCEIVER fabricated with sub-micron silicon gate and five-layer metal wiring C<sup>2</sup>MOS technology. Designed for use as an interface between a 3.3V bus and a 2.5V or 1.8V bus in a mixed 3.3V/1.8V, 3.3V/2.5V and 2.5V/1.8V supply systems, it achieves high speed operation while maintaining the CMOS low power dissipation and it includes 2-bit I<sup>2</sup>C level translation. This IC is intended for two-way asynchronous communication between data buses and the direction of data transmission is determined by nDIR inputs. The enable inputs nG can be used to disable the device so that the buses are effectively isolated. The A-port interfaces with the 3V bus, the B-port with the 2.5V and 1.8V bus. All inputs are equipped with protection circuits against static discharge, giving them 2KV ESD immunity and transient excess voltage. All floating bus terminals during High Z State don't need external pull-up or pull-down resistor.

October 2004

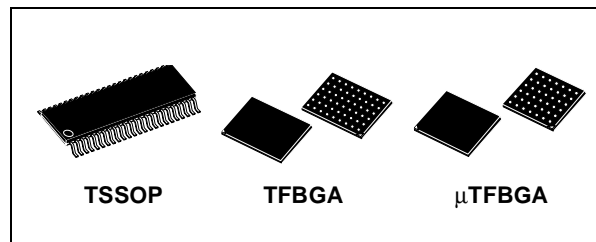
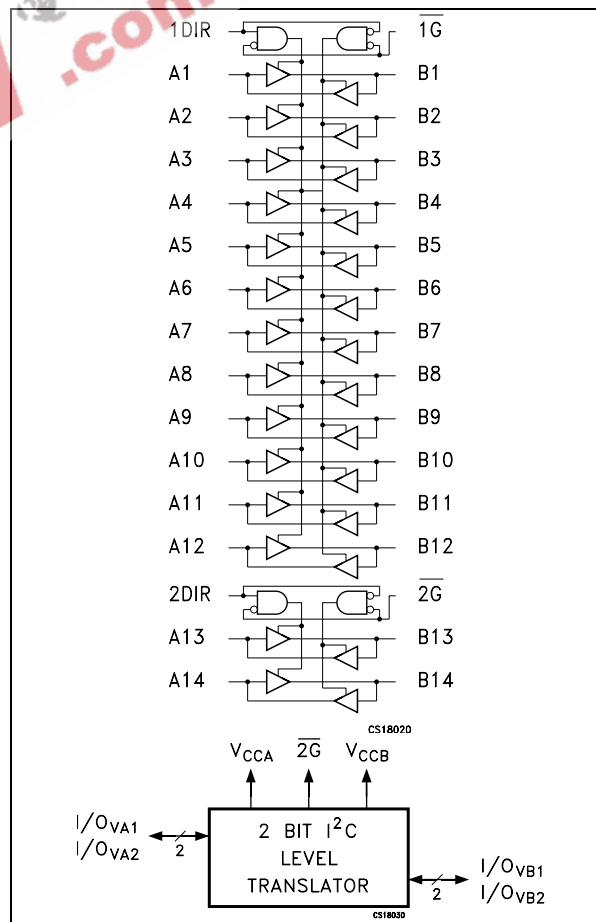

Table 1: Order Codes

PACKAGE	T & R
TSSOP48	ST16C32245TTR
TFBGA54	ST16C32245LBR
μTFBGA42	ST16C32245TBR

Figure 1: Logic Diagram



Rev. 1

1/20

Figure 2: Input And Output Equivalent Circuit

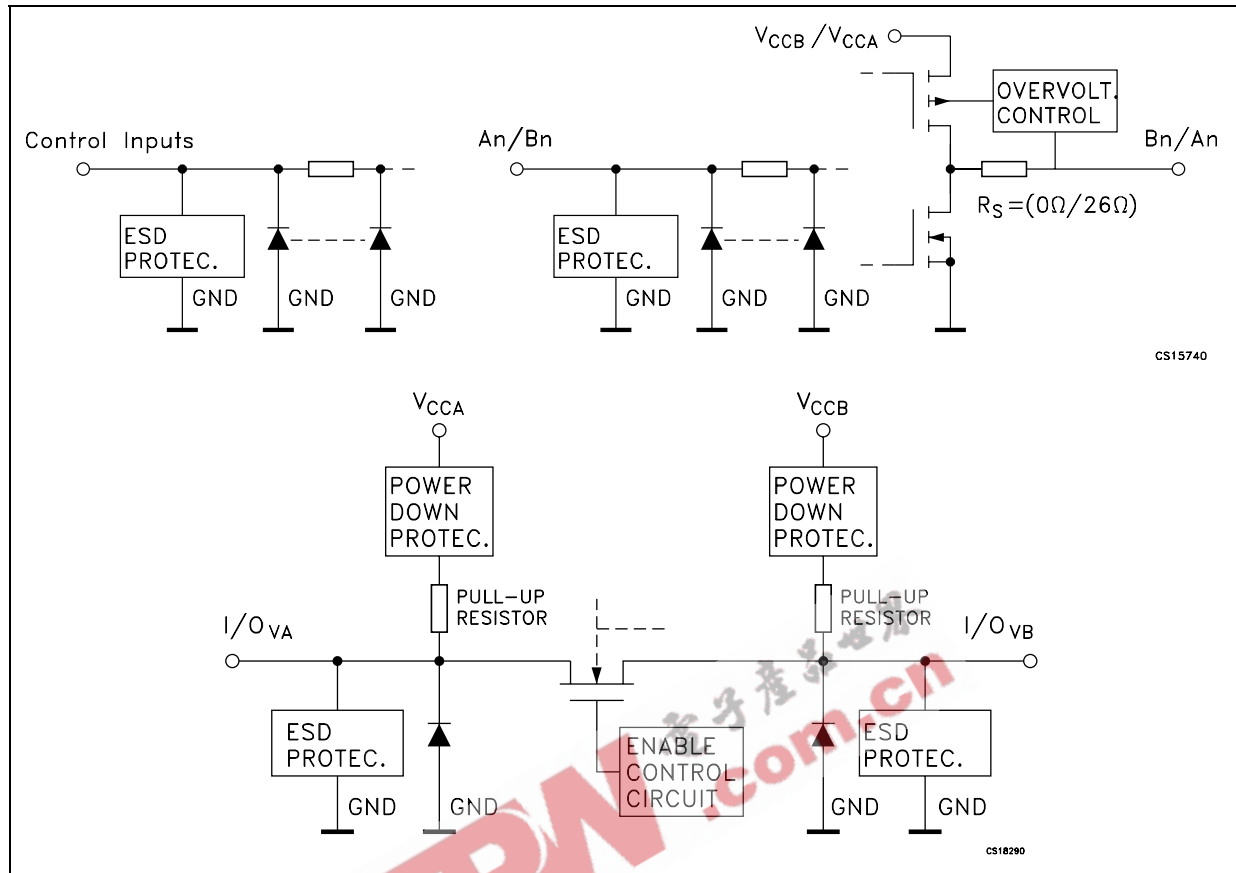

Table 2: Pin Description

TFBGA54 PIN N°	μTFBGA42 PIN N°	TSSOP PIN N°	SYMBOL	NAME AND FUNCTION
A3	B3	1	1DIR	Directional Controls
J3	F3	24	2DIR	Directional Controls
A6, B5, B6, C5, C6, D5, D6, E5	A4, A5, A6, B5, B6, C5, C6, D5	47, 46, 44, 43, 41, 40, 38, 37	1A1, 1A2, 1A3, 1A4, 1A5, 1A6, 1A7, 1A8	Data Inputs/Outputs
E6, F5, F6, G5, G6, H5	D6, E5, E6, F5, F6, G6	36, 35, 33, 32, 30, 29	1A9, 1A10, 1A11, 1A12, 2A13, 2A14	Data Inputs/Outputs
A1, B2, B1, C2, C1, D2, D1, E2	A3, A2, A1, B2, B1, C2, C1, D2	2, 3, 5, 6, 8, 9, 11, 12	1B1, 1B2, 1B3, 1B4, 1B5, 1B6, 1B7, 1B8	Data Inputs/Outputs
E1, F2, F1, G2, G1, H2	D1, E2, E1, F2, F1, G1	13, 14, 16, 17, 19, 20	1B9, 1B10, 1B11, 1B12, 2B13, 2B14	Data Inputs/Outputs
J4	F4	25	2G	Output Enable Inputs
A4	B4	48	1G	Output Enable Inputs
D3, D4, E3, E4, F3, F4	C3, C4, E3, E4	4, 10, 15, 21, 28, 34, 39, 45	GND	Ground (0V)
A2, A5, B3, B4, H3, H4, J2, J5	-	-	NC	No Connected
C4, G4	D4	42, 31	V <sub>CCA</sub>	Positive Supply Voltage
C3, G3	D3	7, 18	V <sub>CCB</sub>	Positive Supply Voltage
H6, J6	G5, G4	27, 26	I/O <sub>VA1</sub> , I/O <sub>VA2</sub>	I <sup>2</sup> C Line (V <sub>CCA</sub> Referred)
H1, J1	G2, G3	22, 23	I/O <sub>VB1</sub> , I/O <sub>VB2</sub>	I <sup>2</sup> C Line (V <sub>CCB</sub> Referred)

Figure 3: Pin Connection (top view for TSSOP, top through view for BGA)

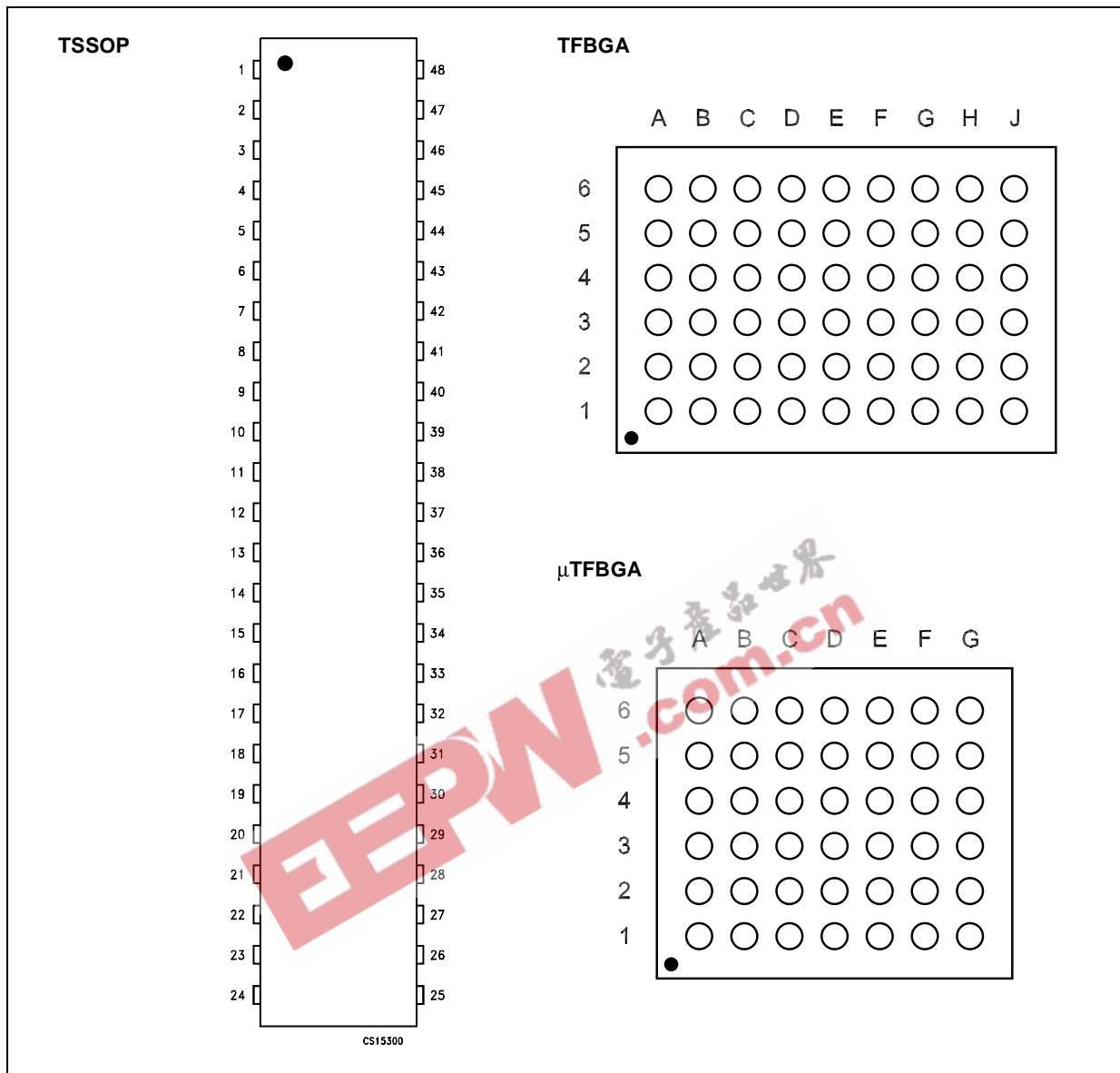

Table 3: Truth Table

INPUTS		FUNCTION		OUTPUT
$\bar{G}$	DIR	A BUS	B BUS	
L	L	OUTPUT	INPUT	A = B
L	H	INPUT	OUTPUT	B = A
H	X	Z	Z	Z

X=Don't care; Z=High Impedance

Table 4: I<sup>2</sup>C Bus Function Table

$\overline{2G}$	$\overline{1G}$ , 1DIR, 2DIR	I/O INPUT		FUNCTION
		I/O <sub>VA</sub>	I/O <sub>VB</sub>	
H	X	Z	Z	I <sup>2</sup> C Disabled
L	X	L	L	I <sup>2</sup> C Comm.
L	X	V <sub>CCA</sub>	V <sub>CCB</sub>	I <sup>2</sup> C Comm.
L	X	Open	V <sub>CCB</sub>	I <sup>2</sup> C Comm.
L	X	V <sub>CCA</sub>	Open	I <sup>2</sup> C Comm.

Open: If I/O<sub>VA</sub> is not driven then the I/O<sub>VB</sub> will go in high level V<sub>CCB</sub> by embedded 10kΩ pull-up resistor; If I/O<sub>VB</sub> is not driven then the I/O<sub>VA</sub> will go in high level V<sub>CCA</sub> by embedded 10kΩ pull-up resistor.

Table 5: Absolute Maximum Ratings

Symbol	Parameter	Value	Unit
V <sub>CCA</sub>	Supply Voltage	-0.5 to +4.6	V
V <sub>CCB</sub>	Supply Voltage	-0.5 to +4.6	V
V <sub>I</sub>	DC Input Voltage	-0.5 to +4.6	V
V <sub>I/OA</sub>	DC I/O Voltage (Output disabled)	-0.5 to +4.6	V
V <sub>I/OB</sub>	DC I/O Voltage (Output disabled)	-0.5 to +4.6	V
V <sub>I/OA</sub>	DC I/O Voltage	-0.5 to V <sub>CCA</sub> + 0.5	V
V <sub>I/OB</sub>	DC I/O Voltage	-0.5 to V <sub>CCB</sub> + 0.5	V
V <sub>I/OVA</sub>	Level Input Voltage (I/O <sub>VA</sub> )	-0.5 to V <sub>CCA</sub> + 0.5	V
V <sub>I/OVB</sub>	Level Input Voltage (I/O <sub>VB</sub> )	-0.5 to V <sub>CCB</sub> + 0.5	V
I <sub>IK</sub>	DC Input Diode Current	- 20	mA
I <sub>OK</sub>	DC Output Diode Current	- 50	mA
I <sub>OA</sub>	DC Output Current	± 50	mA
I <sub>OB</sub>	DC Output Current	± 50	mA
I <sub>CCA</sub>	DC V <sub>CC</sub> or Ground Current	± 100	mA
I <sub>CCB</sub>	DC V <sub>CC</sub> or Ground Current	± 100	mA
P <sub>d</sub>	Power Dissipation	400	mW
T <sub>stg</sub>	Storage Temperature	-65 to +150	°C
T <sub>L</sub>	Lead Temperature (10 sec)	260	°C

Absolute Maximum Ratings are those value beyond which damage to the device may occur. Functional operation under these conditions is not implied

Table 6: Recommended Operating Conditions

Symbol	Parameter	Value	Unit
$V_{CCA}$	Supply Voltage	2.3 to 3.6	V
$V_{CCB}$	Supply Voltage	1.65 to 2.7	V
$V_I$	Input Voltage (Dir, $\bar{G}$ )	0 to $V_{CCB}$	V
$V_{I/OA}$	I/O Voltage	0 to $V_{CCA}$	V
$V_{I/OB}$	I/O Voltage	0 to $V_{CCB}$	V
$V_{I/OVA}$	Level Input Voltage ( $I/O_{VA}$ )	0 to $V_{CCA}$	V
$V_{I/OVB}$	Level Input Voltage ( $I/O_{VB}$ )	0 to $V_{CCB}$	V
$T_{op}$	Operating Temperature	-40 to 85	°C
dt/dv	Input Rise and Fall Time (note 1)	0 to 10	ns/V

1)  $V_I$  from 0.8V to 2.0V at  $V_{CC} = 3.0V$

EEPW 电子产品世界  
[www.eepw.com.cn](http://www.eepw.com.cn)

Table 7: DC Specification For  $V_{CCA}$ 

Symbol	Parameter	Test Condition			Value					Unit
		$V_{CCB}$ (V)	$V_{CCA}$ (V)		$T_A = 25\text{ }^\circ\text{C}$			$-40\text{ to }85\text{ }^\circ\text{C}$		
					Min.	Typ.	Max.	Min.	Max.	
$V_{IHA}$	High Level Input Voltage (An) (*)	1.8	2.5		1.6			1.6		V
		1.8	3.3		2.0			2.0		
		2.5	3.3		2.0			2.0		
$V_{ILA}$	Low Level Input Voltage (An) (*)	1.8	2.5				0.7		0.7	V
		1.8	3.3				0.8		0.8	
		2.5	3.3				0.8		0.8	
$V_{OHA}$	High Level Output Voltage	2.3	3.0	$I_O = -100\mu\text{A}$	2.8			2.8		V
		2.3	3.0	$I_O = -8\text{mA}$	2.4			2.4		
		1.65	3.0	$I_O = -8\text{mA}$	2.4			2.4		
		1.65	2.3	$I_O = -6\text{mA}$	1.8			1.8		
$V_{OLA}$	Low Level Output Voltage	2.3	3.0	$I_O = 100\mu\text{A}$			0.2		0.2	V
		2.3	3.0	$I_O = 8\text{mA}$			0.55		0.55	
		1.65	3.0	$I_O = 8\text{mA}$			0.55		0.55	
		1.65	2.3	$I_O = 6\text{mA}$			0.40		0.40	
$I_{IA}$	Input Leakage Current	2.7	3.6	$V_I = V_{CC}$ or GND			$\pm 0.5$		$\pm 5$	$\mu\text{A}$
$I_{IA(\text{HOLD})}$	Input Hold Current	1.65	2.3	$V_I = 0.7\text{ V}$	45			45		$\mu\text{A}$
		1.65	2.3	$V_I = 1.6\text{ V}$	-45			-45		
		1.65	3.0	$V_I = 0.8\text{ V}$	75			75		
		1.65	3.0	$V_I = 2.0\text{ V}$	-75			-75		
		2.3	3.0	$V_I = 0.8\text{ V}$	75			75		
		2.3	3.0	$V_I = 2.0\text{ V}$	-75			-75		
		2.7	3.6	$V_I = 0\text{ to }3.6\text{ V}$					$\pm 500$	
$I_{OZA}$	High Impedance Output Leakage Current	2.7	3.6	$V_{IA} = \text{GND or } 3.6\text{V}$ $V_{IB} = V_{IHB} \text{ or } V_{ILB}$ $\overline{G} = V_{CCB}$			$\pm 1.0$		$\pm 10$	$\mu\text{A}$
$I_{OFF}$	Power Off Leakage Current	0	0	$V_{IA} = \text{GND to } 3.6\text{V}$ $V_{IB} = \text{GND to } 3.6\text{V}$ $\overline{G}, \text{Dir} = \text{GND to } 3.6\text{V}$			$\pm 1.0$		$\pm 10$	$\mu\text{A}$
$I_{OFF12C}$	Power Off $I^2C$ Line Leakage Current	1.65 to 2.7	0	$I/O_{VA1,2} = \text{GND or } V_{CCA}$ ; $I/O_{VB1,2} = \text{GND or } V_{CCB}$ ; $\overline{2G} = V_{CCB}$			1.0		5	$\mu\text{A}$
$I_{CC1A}$	Quiescent Supply Current	1.95	3.6	$V_{IA} = V_{CCA}$ or GND			2		20	$\mu\text{A}$
		1.95	2.7	$V_{IB} = V_{CCB}$ or GND						
		2.7	3.6	$I/O_{VA1,2} = V_{CCA}$ or Open; Dir, $\overline{G} = \text{GND or } V_{CCB}$						
$\Delta I_{CC1A}$	Maximum Quiescent Supply Current / Input (An)	2.7	3.6						0.75	mA
		1.95	3.6	$V_{IA} = V_{CCA} - 0.6\text{V}$						
		1.95	2.7	$V_{IB} = V_{CCB}$ or GND						

(\*) :  $V_{CC}$  range =  $3.3\pm 0.3$ ;  $2.5\pm 0.2\text{V}$  and  $2.8\pm 0.1\text{V}$ ;  $1.8\pm 0.15\text{V}$

Table 8: DC Specification For  $V_{CCB}$ 

Symbol	Parameter	Test Condition			Value					Unit
		$V_{CCB}$ (V)	$V_{CCA}$ (V)		$T_A = 25\text{ }^\circ\text{C}$			$-40\text{ to }85\text{ }^\circ\text{C}$		
					Min.	Typ.	Max.	Min.	Max.	
$V_{IHB}$	High Level Input Voltage (Bn, Dir, $\overline{G}$ ) (*)	1.8	2.5		0.65 $V_{CCB}$			0.65 $V_{CCB}$		V
		1.8	3.3		0.65 $V_{CCB}$			0.65 $V_{CCB}$		
		2.5	3.3		1.6			1.6		
$V_{ILB}$	Low Level Input Voltage (Bn, Dir, $\overline{G}$ ) (*)	1.8	2.5				0.35 $V_{CCB}$		0.35 $V_{CCB}$	V
		1.8	3.3				0.35 $V_{CCB}$		0.35 $V_{CCB}$	
		2.5	3.3				0.7		0.7	
$V_{OHB}$	High Level Output Voltage	2.3	3.0	$I_O = -100\mu\text{A}$	2.1			2.1		V
		2.3	3.0	$I_O = -18\text{mA}$	1.7			1.7		
		1.65	3.0	$I_O = -6\text{mA}$	1.25			1.25		
		1.65	2.3	$I_O = -6\text{mA}$	1.25			1.25		
$V_{OLB}$	Low Level Output Voltage	2.3	3.0	$I_O = 100\mu\text{A}$			0.2		0.2	V
		2.3	3.0	$I_O = 18\text{mA}$			0.60		0.60	
		1.65	3.0	$I_O = 6\text{mA}$			0.30		0.30	
		1.65	2.3	$I_O = 6\text{mA}$			0.30		0.30	
$I_{IB}$	Input Leakage Current	2.7	3.6	$V_I = V_{CC}$ or GND			$\pm 0.5$		$\pm 5$	$\mu\text{A}$
$I_{IB(\text{HOLD})}$	Input Hold Current	1.65	2.3	$V_I = 0.57\text{ V}$	25			25		$\mu\text{A}$
		1.65	2.3	$V_I = 1.07\text{ V}$	-25			-25		
		1.65	3.0	$V_I = 0.57\text{ V}$	25			25		
		1.65	3.0	$V_I = 1.07\text{ V}$	-25			-25		
		2.3	3.0	$V_I = 0.7\text{ V}$	45			45		
		2.3	3.0	$V_I = 1.6\text{ V}$	-45			-45		
		2.7	3.6	$V_I = 0\text{ to }2.7\text{ V}$					$\pm 500$	
$I_{OZB}$	High Impedance Output Leakage Current	2.7	3.6	$V_{IA} = V_{IHA}$ or $V_{ILA}$ $V_{IB} = \overline{G}$ or 2.7V $\overline{G} = V_{CCB}$			$\pm 1.0$		$\pm 10$	$\mu\text{A}$
$I_{CCIB}$	Quiescent Supply Current	1.95	3.6	$V_{IA} = V_{CCA}$ or GND			2		20	$\mu\text{A}$
		1.95	2.7	$V_{IB} = V_{CCB}$ or GND						
		2.7	3.6	Dir or $\overline{G} = V_{CCB}$ or GND $I/O_{VA1,2} = V_{CCA}$ or Open						
$\Delta I_{CCIB}$	Maximum Quiescent Supply Current / Input (Bn, DIR, $\overline{G}$ )	2.7	3.6						0.75	mA
		1.95	3.6	$V_{IB} = V_{CCB} - 0.6\text{V}$						
		1.95	2.7	$V_{IA} = V_{CCA}$ or GND						

(\*)  $V_{CC}$  range =  $3.3 \pm 0.3$ ;  $2.5 \pm 0.2\text{V}$  and  $2.8 \pm 0.1\text{V}$ ;  $1.8 \pm 0.15\text{V}$

Table 9: DC Specification I<sup>2</sup>C Lines

Symbol	Parameter	Test Condition			Value					Unit
		V <sub>CCB</sub> (V) (*)	V <sub>CCA</sub> (V)		T <sub>A</sub> = 25 °C			-40 to 85 °C		
					Min.	Typ.	Max.	Min.	Max.	
V <sub>IH2</sub>	High Level Input Voltage (I/O <sub>VB1</sub> , I/O <sub>VB2</sub> )	1.8	2.65 to 3.6		0.7xV <sub>CCB</sub>		V <sub>CCB</sub>	0.7xV <sub>CCB</sub>	V <sub>CCB</sub>	V
		1.8	2.65 to 3.6		0.7xV <sub>CCB</sub>		V <sub>CCB</sub>	0.7xV <sub>CCB</sub>	V <sub>CCB</sub>	
	High Level Input Voltage (I/O <sub>VA1</sub> , I/O <sub>VA2</sub> )	1.8	2.65 to 3.6		0.7xV <sub>CCA</sub>		V <sub>CCA</sub>	0.7xV <sub>CCA</sub>	V <sub>CCA</sub>	
		1.8	2.65 to 3.6		0.7xV <sub>CCA</sub>		V <sub>CCA</sub>	0.7xV <sub>CCA</sub>	V <sub>CCA</sub>	
V <sub>IL2</sub>	Low Level Input Voltage (I/O <sub>VB1</sub> , I/O <sub>VB2</sub> )	1.8	2.65 to 3.6		0		0.25	0	0.25	V
		1.8	2.65 to 3.6		0		0.25	0	0.25	
	Low Level Input Voltage (I/O <sub>VA1</sub> , I/O <sub>VA2</sub> )	1.8	2.65 to 3.6		0		0.25	0	0.25	
		1.8	2.65 to 3.6		0		0.25	0	0.25	
V <sub>OH2</sub>	High Level Output Voltage (I/O <sub>VB1</sub> , I/O <sub>VB2</sub> )	1.65	2.3	I <sub>OH</sub> = -20 μA; V <sub>I/OVA</sub> =V <sub>CCA</sub>	V <sub>CCB</sub> -0.4			V <sub>CCB</sub> -0.4		V
	High Level Output Voltage (I/O <sub>VA1</sub> , I/O <sub>VA2</sub> )	1.65	2.3	I <sub>OH</sub> = -20 μA; V <sub>I/OVB</sub> =V <sub>CCB</sub>	V <sub>CCA</sub> -0.4			V <sub>CCA</sub> -0.4		V
V <sub>OL2</sub>	Low Level Output Voltage (I/O <sub>VB1</sub> , I/O <sub>VB2</sub> ), (I/O <sub>VA1</sub> , I/O <sub>VA2</sub> )	1.65	2.3	I <sub>OL</sub> = 1 mA; V <sub>I/OVB</sub> or V <sub>I/OVA</sub> =GND			0.35		0.35	V

(\*) V<sub>CC</sub> range = 1.8±0.15V

Table 10: Dynamic Switching Characteristics

Symbol	Parameter	Test Condition			Value					Unit
		V <sub>CCB</sub> (V)	V <sub>CCA</sub> (V)		T <sub>A</sub> = 25 °C			-40 to 85 °C		
					Min.	Typ.	Max.	Min.	Max.	
V <sub>OLPA</sub>	Dynamic Low Level Quiet An Output	1.8	2.5	C <sub>L</sub> = 30pF V <sub>IL</sub> = 0V V <sub>IH</sub> = V <sub>CC</sub>		0.25				V
		1.8	3.3			0.35				
		2.5	3.3			0.35				
V <sub>OLPB</sub>	Dynamic Low Level Quiet Bn Output	1.8	2.5	C <sub>L</sub> = 30pF V <sub>IL</sub> = 0V V <sub>IH</sub> = V <sub>CC</sub>		0.25				V
		1.8	3.3			0.25				
		2.5	3.3			0.6				
V <sub>OLVA</sub>	Dynamic Low Level Quiet An Output	1.8	2.5	C <sub>L</sub> = 30pF V <sub>IL</sub> = 0V V <sub>IH</sub> = V <sub>CC</sub>		-0.25				V
		1.8	3.3			-0.35				
		2.5	3.3			-0.35				
V <sub>OLVB</sub>	Dynamic Low Level Quiet Bn Output	1.8	2.5	C <sub>L</sub> = 30pF V <sub>IL</sub> = 0V V <sub>IH</sub> = V <sub>CC</sub>		-0.25				V
		1.8	3.3			-0.25				
		2.5	3.3			-0.6				
V <sub>OHVA</sub>	Dynamic High Level Quiet An Output	1.8	2.5	C <sub>L</sub> = 30pF V <sub>IL</sub> = 0V V <sub>IH</sub> = V <sub>CC</sub>		2.1				V
		1.8	3.3			2.6				
		2.5	3.3			2.6				
V <sub>OHVB</sub>	Dynamic High Level Quiet Bn Output	1.8	2.5	C <sub>L</sub> = 30pF V <sub>IL</sub> = 0V V <sub>IH</sub> = V <sub>CC</sub>		1.7				V
		1.8	3.3			1.7				
		2.5	3.3			2.0				



Table 11: AC Electrical Characteristics

Symbol	Parameter	Test Condition			Value		Unit
		V <sub>CCB</sub> (V)	V <sub>CCA</sub> (V)		-40 to 85 °C		
					Min.	Max.	
t <sub>PLH</sub> t <sub>PHL</sub>	Propagation Delay Time An to Bn	1.8 ± 0.15	2.5 ± 0.2	C <sub>L</sub> = 30 pF R <sub>L</sub> = 500 Ω	1.0	5.8	ns
		1.8 ± 0.15	3.3 ± 0.3		1.0	6.2	
		2.5 ± 0.2	3.3 ± 0.3		1.0	4.4	
t <sub>PLH</sub> t <sub>PHL</sub>	Propagation Delay Time Bn to An (nota 3)	1.8 ± 0.15	2.5 ± 0.2	C <sub>L</sub> = 30 pF R <sub>L</sub> = 500 Ω	1.0	5.5	ns
		1.8 ± 0.15	3.3 ± 0.3		1.0	5.1	
		2.5 ± 0.2	3.3 ± 0.3		1.0	4.0	
t <sub>PZL</sub> t <sub>PZH</sub>	Output Enable Time G to An	1.8 ± 0.15	2.5 ± 0.2	C <sub>L</sub> = 30 pF R <sub>L</sub> = 500 Ω	1.0	5.3	ns
		1.8 ± 0.15	3.3 ± 0.3		1.0	5.1	
		2.5 ± 0.2	3.3 ± 0.3		1.0	4.0	
t <sub>PZL</sub> t <sub>PZH</sub>	Output Enable Time G to Bn	1.8 ± 0.15	2.5 ± 0.2	C <sub>L</sub> = 30 pF R <sub>L</sub> = 500 Ω	1.0	8.3	ns
		1.8 ± 0.15	3.3 ± 0.3		1.0	8.2	
		2.5 ± 0.2	3.3 ± 0.3		1.0	4.6	
t <sub>PLZ</sub> t <sub>PHZ</sub>	Output Disable Time G to An	1.8 ± 0.15	2.5 ± 0.2	C <sub>L</sub> = 30 pF R <sub>L</sub> = 500 Ω	1.0	5.2	ns
		1.8 ± 0.15	3.3 ± 0.3		1.0	5.6	
		2.5 ± 0.2	3.3 ± 0.3		1.0	4.8	
t <sub>PLZ</sub> t <sub>PHZ</sub>	Output Disable Time G to Bn	1.8 ± 0.15	2.5 ± 0.2	C <sub>L</sub> = 30 pF R <sub>L</sub> = 500 Ω	1.0	4.6	ns
		1.8 ± 0.15	3.3 ± 0.3		1.0	4.5	
		2.5 ± 0.2	3.3 ± 0.3		1.0	4.4	
t <sub>OSLH</sub> t <sub>OSHL</sub>	Output To Output Skew Time (note1, 2)	1.8 ± 0.15	2.5 ± 0.2	C <sub>L</sub> = 30 pF R <sub>L</sub> = 500 Ω		0.5	ns
		1.8 ± 0.15	3.3 ± 0.3			0.5	
		2.5 ± 0.2	3.3 ± 0.3			0.75	

1) Skew is defined as the absolute value of the difference between the actual propagation delay for any two outputs of the same device switching in the same direction, either HIGH or LOW (t<sub>OSLH</sub> = |t<sub>PLHm</sub> - t<sub>PLHn</sub>|; t<sub>OSHL</sub> = |t<sub>PHLm</sub> - t<sub>PHLn</sub>|)

2) Parameter guaranteed by design

3) To add 2.5ns at t<sub>PLH</sub>, t<sub>PHL</sub> max propagation delay time Bn to An at V<sub>CCB</sub>=1.8±0.15V; V<sub>CCA</sub>=2.8±0.1V; R<sub>L</sub>=500Ω, when C<sub>L</sub>=60 pF

Table 12: AC I<sup>2</sup>C Electrical Characteristics

Symbol	Parameter	Test Condition			Value		Unit
		V <sub>CCB</sub> (V)(*)	V <sub>CCA</sub> (V)(*)		-40 to 85 °C		
					Min.	Max.	
t <sub>ri/O</sub>	Rise Time I <sup>2</sup> C Input/Output Voltage (20% to 80%) (See fig. 3)	1.8 ± 0.15	2.5 ± 0.2	C <sub>L</sub> = 15 pF t <sub>ri/O</sub> = 15ns		250	ns
		1.8 ± 0.15	3.3 ± 0.3				
		2.5 ± 0.2	3.3 ± 0.3				
t <sub>fi/O</sub>	Fall Time I <sup>2</sup> C Input/Output Voltage (80% to 20%) (See fig. 3)	1.8 ± 0.15	2.5 ± 0.2	C <sub>L</sub> = 15 pF t <sub>fi/O</sub> = 15ns		250	ns
		1.8 ± 0.15	3.3 ± 0.3				
		2.5 ± 0.2	3.3 ± 0.3				
t <sub>PLH</sub>	Propagation Delay Time I <sup>2</sup> C I/O Voltage (20% to 80%) (Low to High) (fig. 3)	1.8 ± 0.15	2.5 ± 0.2	C <sub>L</sub> = 15 pF t <sub>ri/O</sub> = 15ns		100	ns
		1.8 ± 0.15	3.3 ± 0.3				
		2.5 ± 0.2	3.3 ± 0.3				
t <sub>PHL</sub>	Propagation Delay Time I <sup>2</sup> C I/O Voltage (20% to 80%) High to Low) (fig. 3)	1.8 ± 0.15	2.5 ± 0.2	C <sub>L</sub> = 15 pF t <sub>ri/O</sub> = 15ns		100	ns
		1.8 ± 0.15	3.3 ± 0.3				
		2.5 ± 0.2	3.3 ± 0.3				
f <sub>I/OVA</sub> , f <sub>I/OVB</sub>	I <sup>2</sup> C lines data rate	1.8 ± 0.15	2.5 ± 0.2	C <sub>L</sub> = 15 pF t <sub>ri/O</sub> = 15ns	400		KHz
		1.8 ± 0.15	3.3 ± 0.3				
		2.5 ± 0.2	3.3 ± 0.3				

(\*) V<sub>CC</sub> range = 3.3±0.3; 2.5±0.2V and 2.8±0.1V; 1.8±0.15V

Table 13: Capacitance Characteristics

Symbol	Parameter	Test Condition		Value					Unit
		V <sub>CCB</sub> (V)	V <sub>CCA</sub> (V)	T <sub>A</sub> = 25 °C			-40 to 85 °C		
				Min.	Typ.	Max.	Min.	Max.	
C <sub>INB</sub>	Input Capacitance	open	open		5				pF
C <sub>I/O</sub>	Input/Output Capacitance	2.5	3.3		6				pF
C <sub>PD</sub>	Power Dissipation Capacitance	2.5	3.3	f=10MHz	28				pF
		1.8	3.3		28				pF

1) C<sub>PD</sub> is defined as the value of the IC's internal equivalent capacitance which is calculated from the operating current consumption without load. (Refer to Test Circuit). Average current can be obtained by the following equation. I<sub>CC(opr)</sub> = C<sub>PD</sub> × V<sub>CC</sub> × f<sub>IN</sub> + I<sub>CC</sub>/14 (per circuit)

Figure 4: Test Circuit

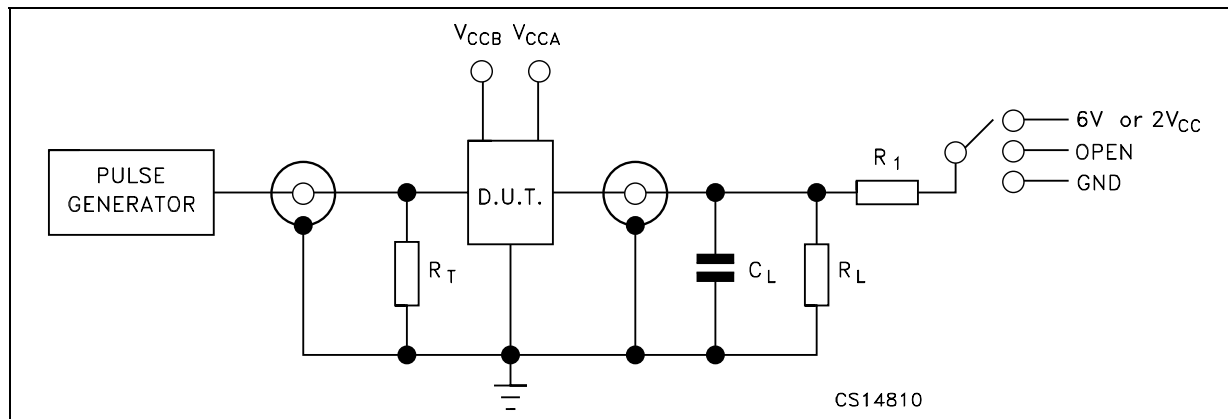

TEST	SWITCH
$t_{PLH}$ , $t_{PHL}$	Open
$t_{PZL}$ , $t_{PLZ}$ ( $V_{CC} = 3.0$ to $3.6V$ )	6V
$t_{PZL}$ , $t_{PLZ}$ ( $V_{CC} = 2.3$ to $2.8V$ or $V_{CC} = 1.65$ to $1.95V$ )	$2V_{CC}$
$t_{PZH}$ , $t_{PHZ}$	GND

$C_L = 30pF$  or equivalent (includes jig and probe capacitance)  
 $R_L = R_1 = 500\Omega$  or equivalent  
 $R_T = Z_{OUT}$  of pulse generator (typically  $50\Omega$ )

Table 14: Waveform Symbol Value

Symbol	$V_{CC}$		
	3.0 to 3.6V	2.3 to 2.8V	1.65 to 1.95V
$V_{IH}$	$V_{CC}$	$V_{CC}$	$V_{CC}$
$V_M$	1.5V	$V_{CC}/2$	$V_{CC}/2$
$V_X$	$V_{OL} + 0.3V$	$V_{OL} + 0.15V$	$V_{OL} + 0.15V$
$V_Y$	$V_{OL} - 0.3V$	$V_{OL} - 0.15V$	$V_{OL} - 0.15V$

Figure 5: Waveform - Propagation Delay ( $f=1MHz$ ; 50% duty cycle)

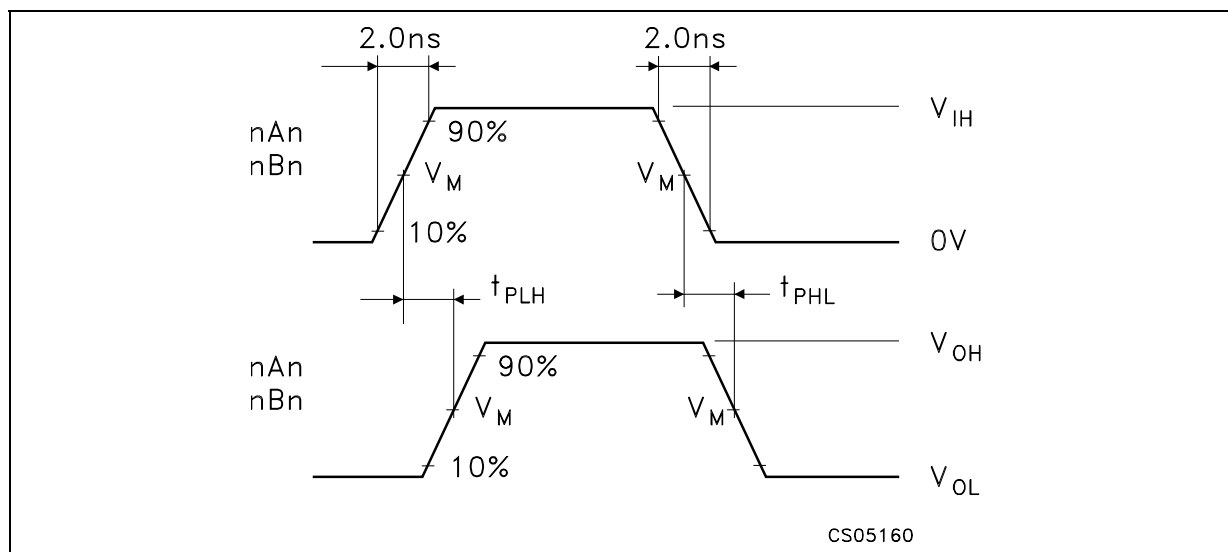

Figure 6: Waveform - Output Enable And Disable Time (f=1MHz; 50% duty cycle)

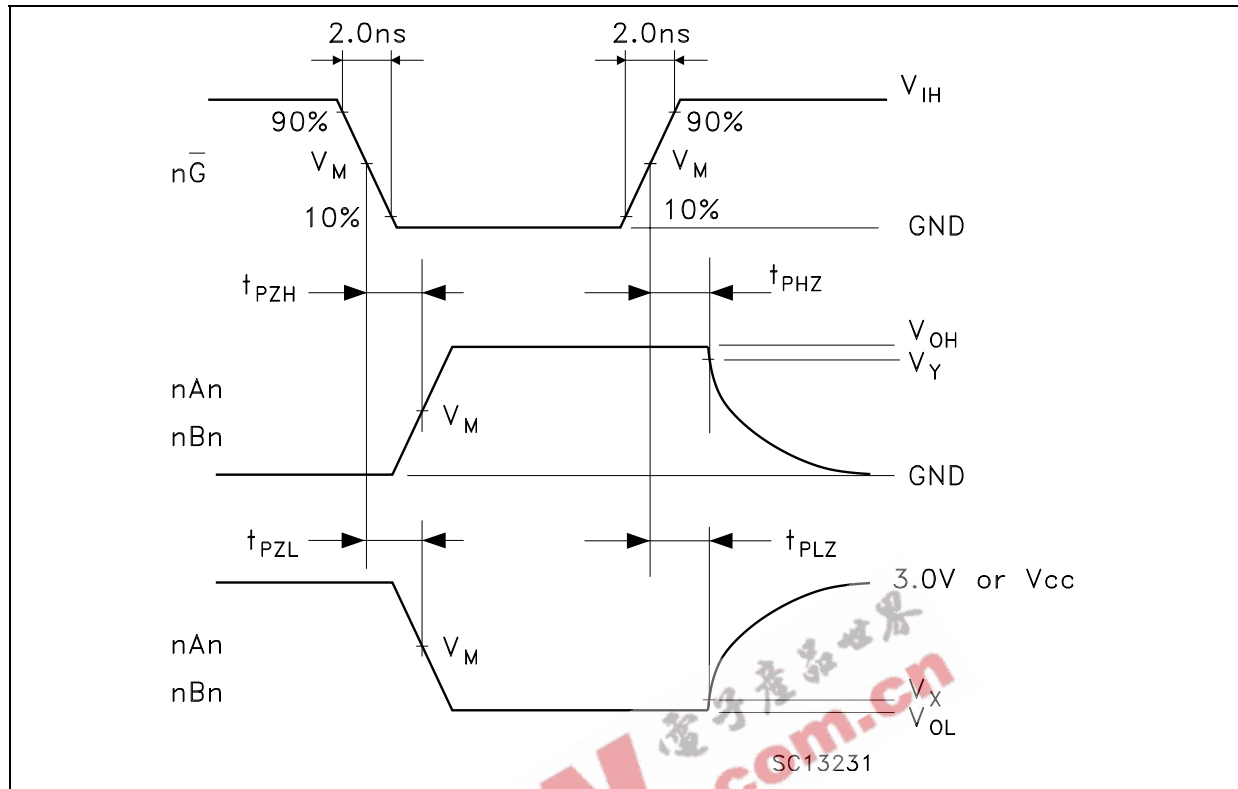
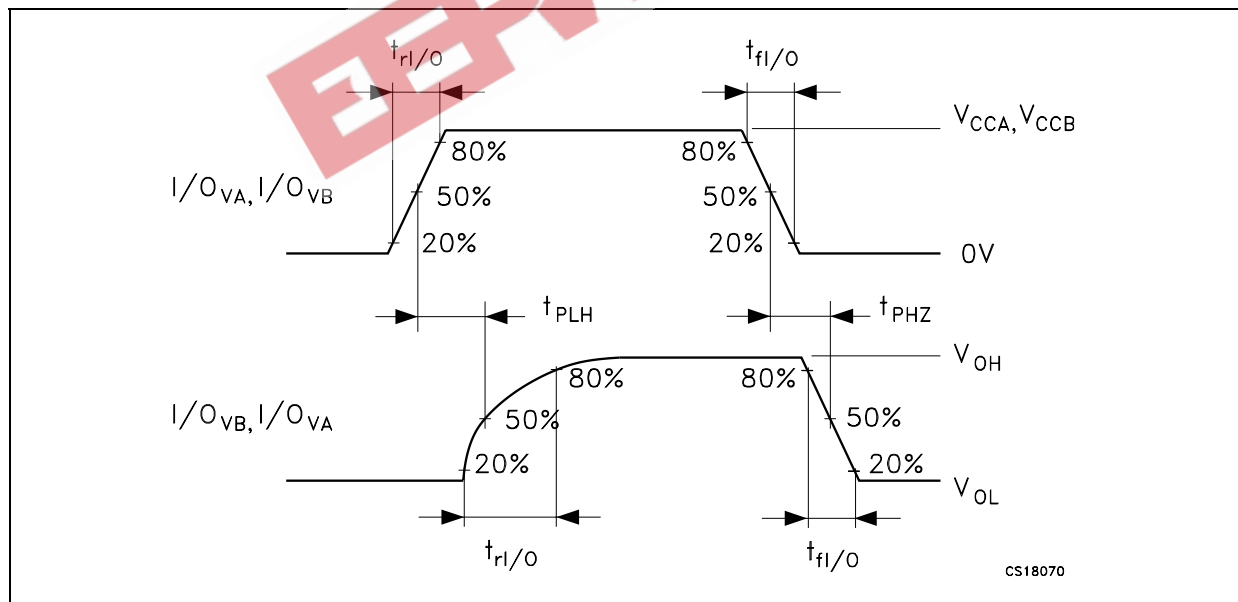
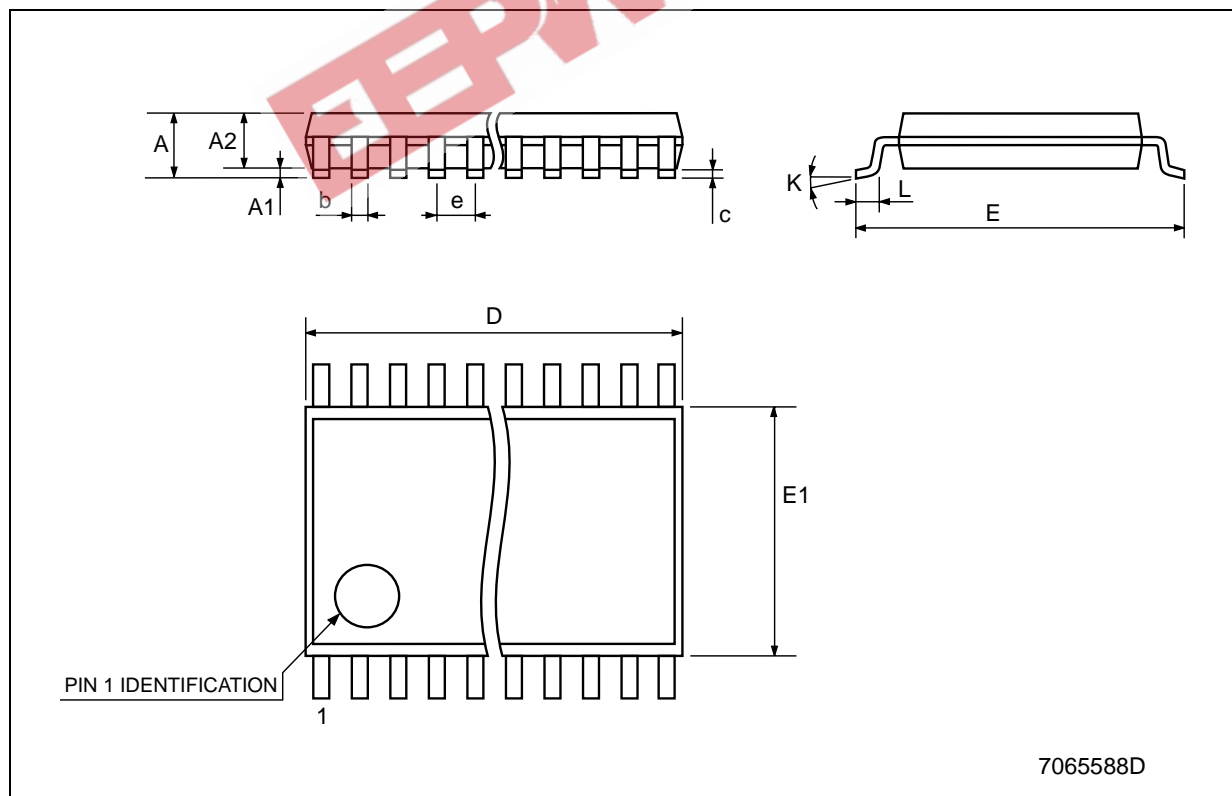

Figure 7: Waveform - I<sup>2</sup>C Propagation Delay Time (f = 400KHz; 50% duty cycle, C<sub>L</sub> = 15pF)



## TSSOP48 MECHANICAL DATA

DIM.	mm.			inch		
	MIN.	TYP	MAX.	MIN.	TYP.	MAX.
A			1.2			0.047
A1	0.05		0.15	0.002		0.006
A2		0.9			0.035	
b	0.17		0.27	0.0067		0.011
c	0.09		0.20	0.0035		0.0079
D	12.4		12.6	0.488		0.496
E		8.1 BSC			0.318 BSC	
E1	6.0		6.2	0.236		0.244
e		0.5 BSC			0.0197 BSC	
K	0°		8°	0°		8°
L	0.45		0.75	0.018		0.030



**TFBGA54 MECHANICAL DATA**

DIM.	mm.			mils		
	MIN.	TYP	MAX.	MIN.	TYP.	MAX.
A			1.2			47.2
A1	0.25			9.8		
A2	0.78		0.86	30.7		33.8
B	0.35	0.4	0.45	13.7	15.7	17.7
D	7.9		8.1	311.0		318.9
D1		6.4			252.0	
E	5.4	5.5	5.6	212.6	216.5	220.5
E1		4			157.5	
e		0.8			31.5	
SE		0.4			15.7	

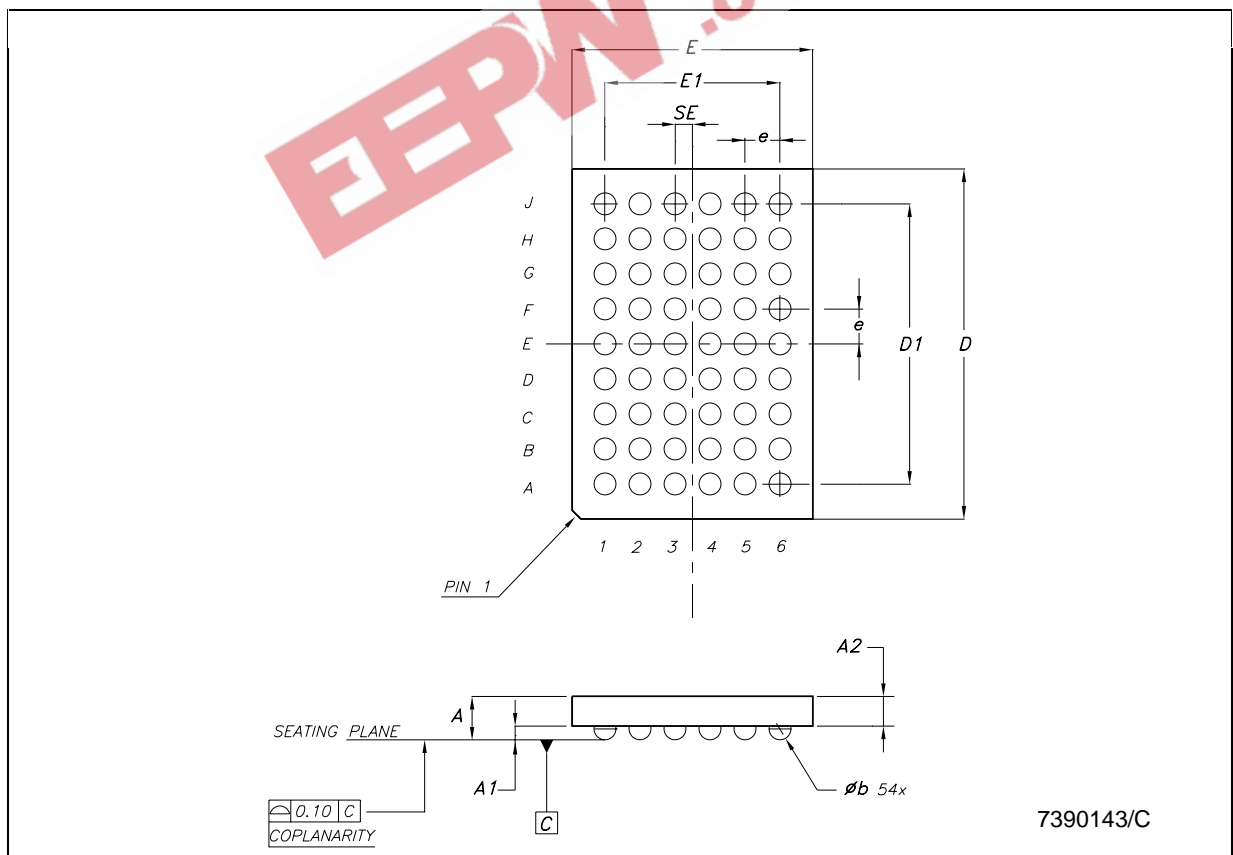

7390143/C

**μTFBGA42 MECHANICAL DATA**

DIM.	mm.			mils		
	MIN.	TYP.	MAX.	MIN.	TYP.	MAX.
A	1.0	1.1	1.16	39.4	43.3	45.7
A1			0.25			9.8
A2	0.78		0.86	30.7		33.9
b	0.25	0.30	0.35	9.8	11.8	13.8
D	3.9	4.0	4.1	153.5	157.5	161.4
D1		3			118.1	
E	3.4	3.5	3.6	133.9	137.8	141.7
E1		2.5			98.4	
e		0.5			19.7	
SE		0.25			9.8	

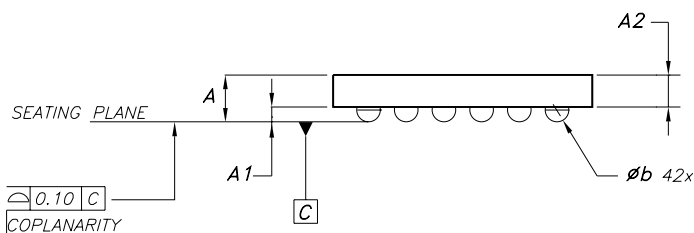
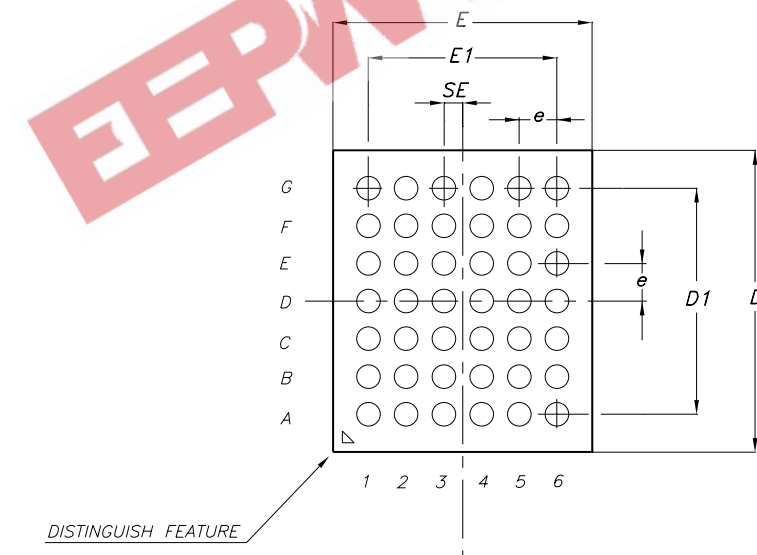

7513237/A

**Tape & Reel TSSOP48 MECHANICAL DATA**

DIM.	mm.			inch		
	MIN.	TYP	MAX.	MIN.	TYP.	MAX.
A			330			12.992
C	12.8		13.2	0.504		0.519
D	20.2			0.795		
N	60			2.362		
T			30.4			1.197
Ao	8.7		8.9	0.343		0.350
Bo	13.1		13.3	0.516		0.524
Ko	1.5		1.7	0.059		0.067
Po	3.9		4.1	0.153		0.161
P	11.9		12.1	0.468		0.476

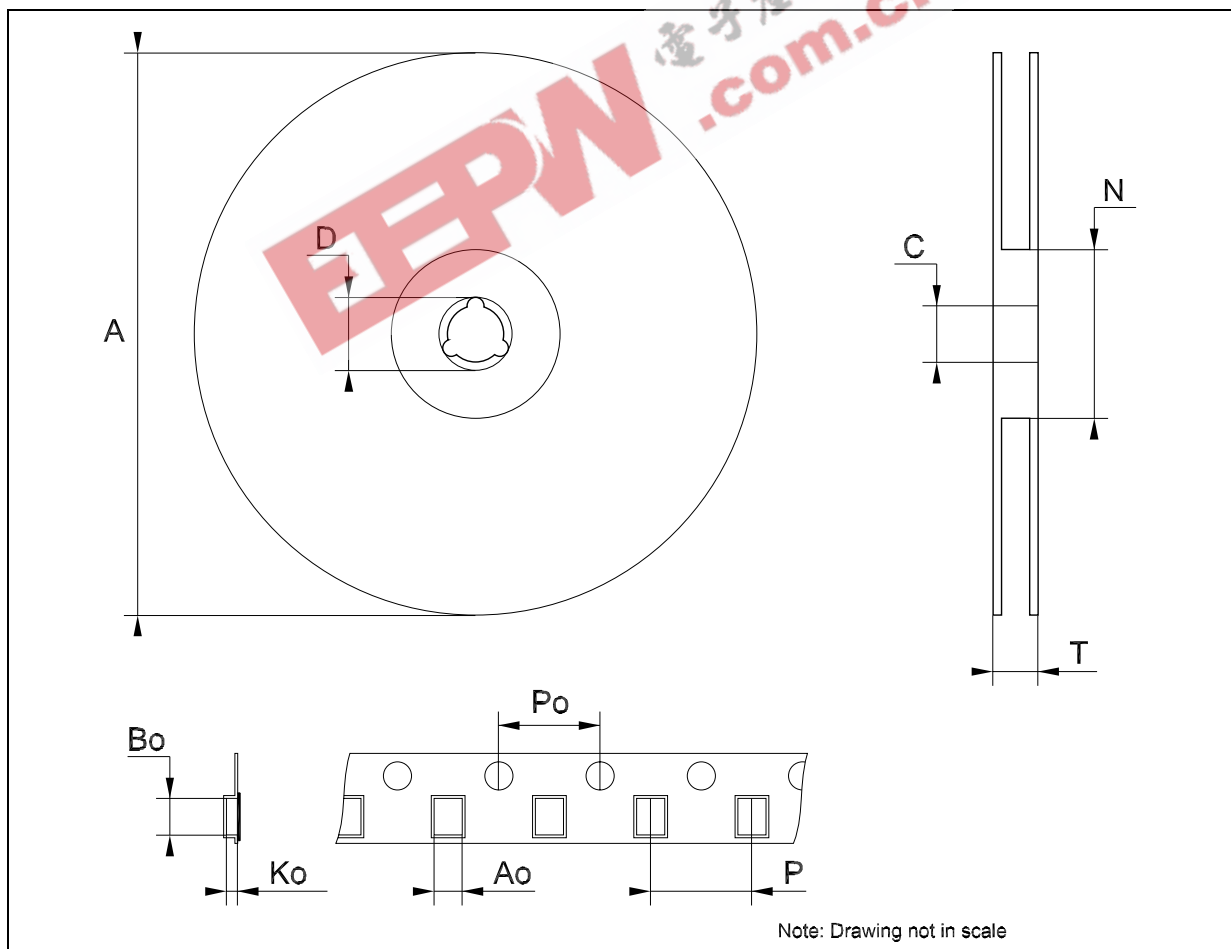



## Tape &amp; Reel TFBGA42 MECHANICAL DATA

DIM.	mm.			inch		
	MIN.	TYP	MAX.	MIN.	TYP.	MAX.
A			330			12.992
C	12.8		13.2	0.504		0.519
D	20.2			0.795		
N	60			2.362		
T			14.4			0.567
Ao		3.8			0.149	
Bo		4.3			0.169	
Ko		1.05			0.041	
Po	3.9		4.1	0.153		0.161
P	7.9		8.1	0.311		0.319

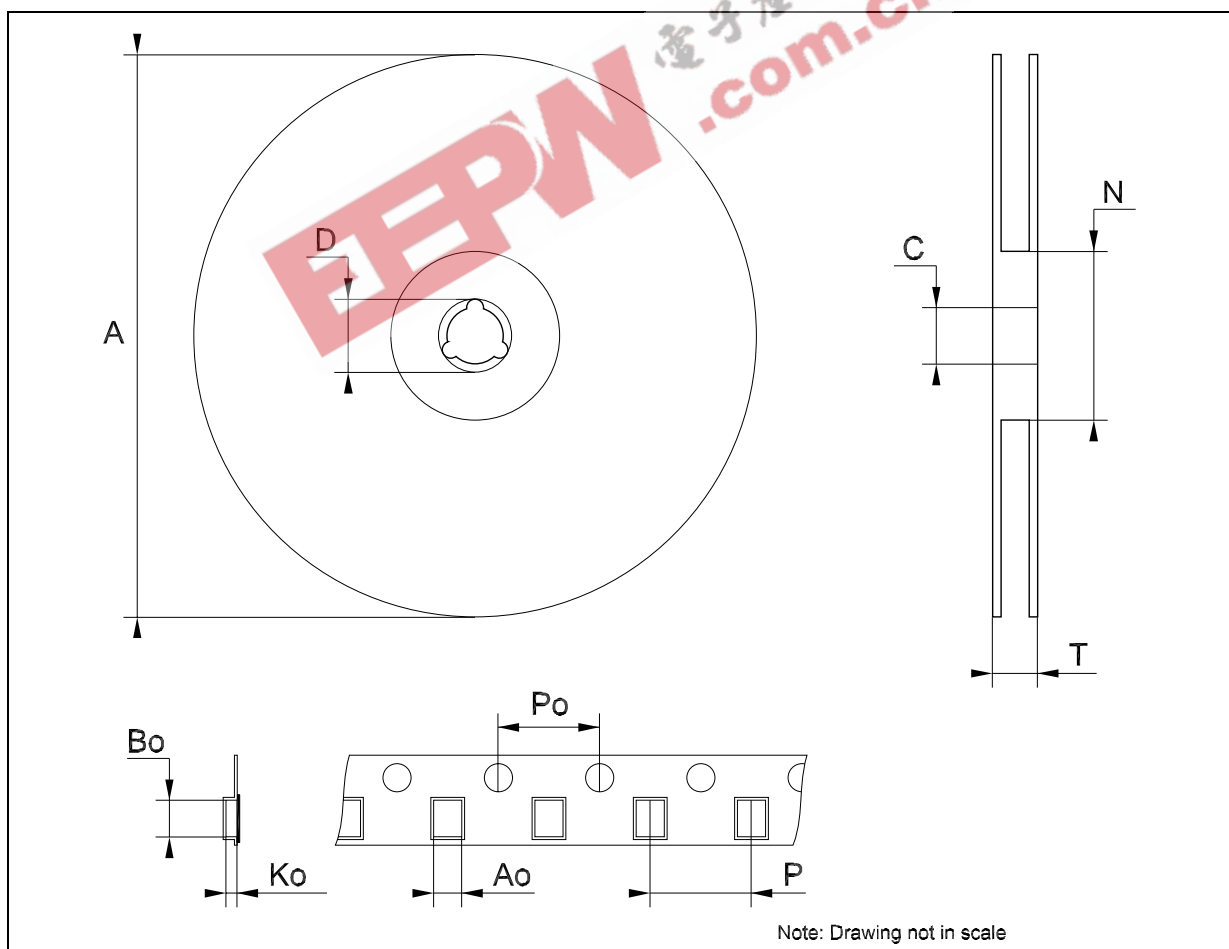

**Tape & Reel TFBGA54 MECHANICAL DATA**

DIM.	mm.			inch		
	MIN.	TYP	MAX.	MIN.	TYP.	MAX.
A			330			12.992
C	12.8		13.2	0.504		0.519
D	20.2			0.795		
N	60			2.362		
T			22.4			0.882
Ao		6.1			0.240	
Bo		8.6			0.339	
Ko		1.8			0.071	
Po	3.9		4.1	0.153		0.161
P	7.9		8.1	0.311		0.319

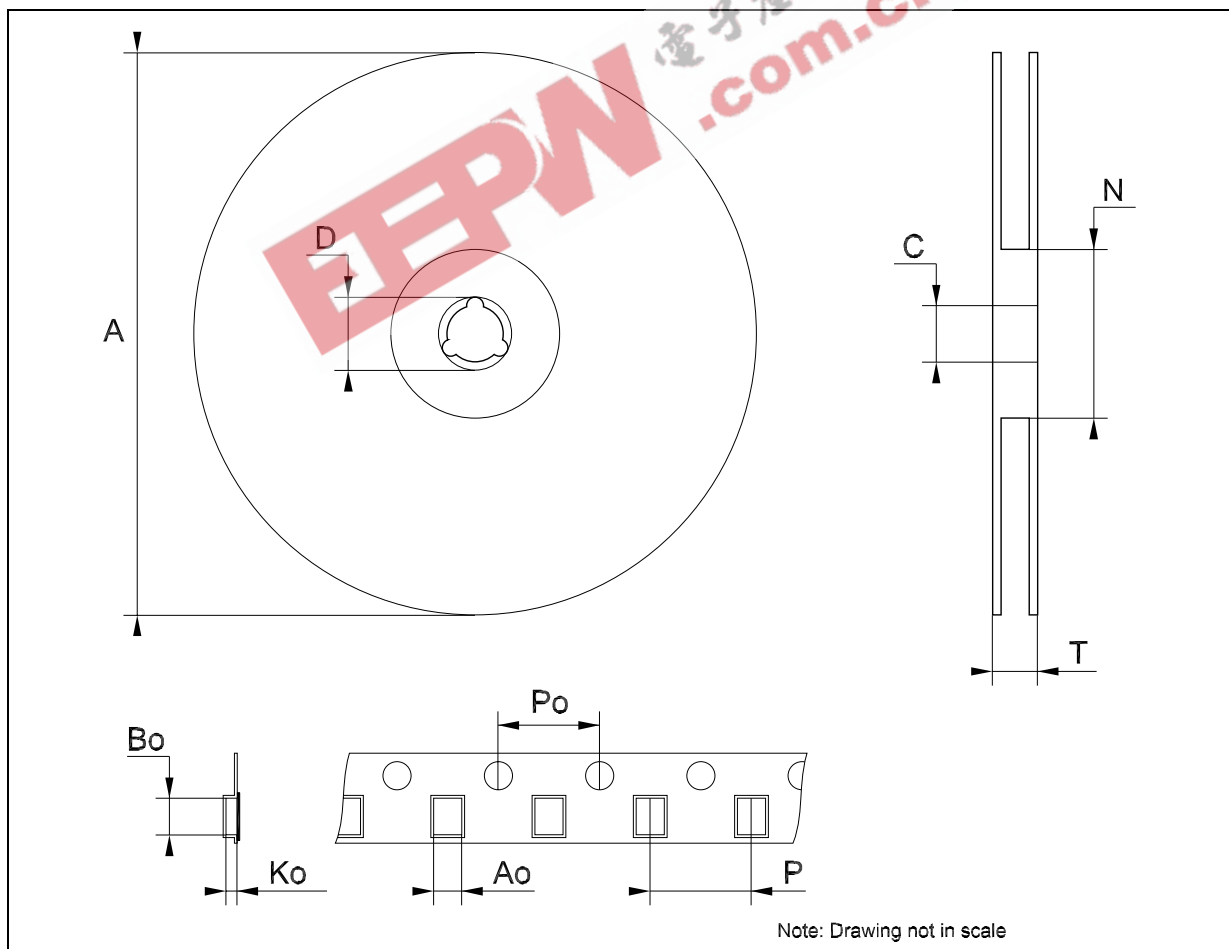

Table 15: Revision History

Date	Revision	Description of Changes
01-Oct-2004	1	First Release.

EEPW 电子产品世界  
.com.cn



Information furnished is believed to be accurate and reliable. However, STMicroelectronics assumes no responsibility for the consequences of use of such information nor for any infringement of patents or other rights of third parties which may result from its use. No license is granted by implication or otherwise under any patent or patent rights of STMicroelectronics. Specifications mentioned in this publication are subject to change without notice. This publication supersedes and replaces all information previously supplied. STMicroelectronics products are not authorized for use as critical components in life support devices or systems without express written approval of STMicroelectronics.

The ST logo is a registered trademark of STMicroelectronics  
All other names are the property of their respective owners

© 2004 STMicroelectronics - All Rights Reserved

STMicroelectronics group of companies

Australia - Belgium - Brazil - Canada - China - Czech Republic - Finland - France - Germany - Hong Kong - India - Israel - Italy - Japan - Malaysia - Malta - Morocco - Singapore - Spain - Sweden - Switzerland - United Kingdom - United States of America

[www.st.com](http://www.st.com)