

2 WATT REGULATED WIDE INPUT RANGE DC/DC CONVERTER

WFC02R



FEATURES

- Low Cost, High Performance
- Small DIP Package
- Full Power to +85°C
- Extended Temperature Range: -40°C to +85°C
- Industry Standard Pinouts
- Full Short Circuit Protection
- High Capacitive Loading Capability
- Protected Against High Input Voltage

APPLICATIONS

- Telecommunications
- Battery Powered Systems
- Portable Instruments
- Process Control Equipment
- Transportation Equipment
- Distributed Power Systems

DESCRIPTION

The WFC02R is a family of high performance DC/DC converters that offers regulated outputs over input voltage ranges of 9-36V and 18-72V while offering a wide operating temperature range of -40°C to +85°C without derating.

Each WFC02R contains input filtering to minimize conducted noise. The design utilizes surface mounted components, including magnetics, to provide enhanced reliability.

The converter is designed to meet the requirements of EN60950 with the "L" pinout having 1,500 VDC isolation. All WFC02R converters are designed to withstand input voltage transients to 200% of nominal input voltage. An additional feature is the ability of the WFC02R to drive high capacitive loads.

SIMPLIFIED CIRCUIT DIAGRAM

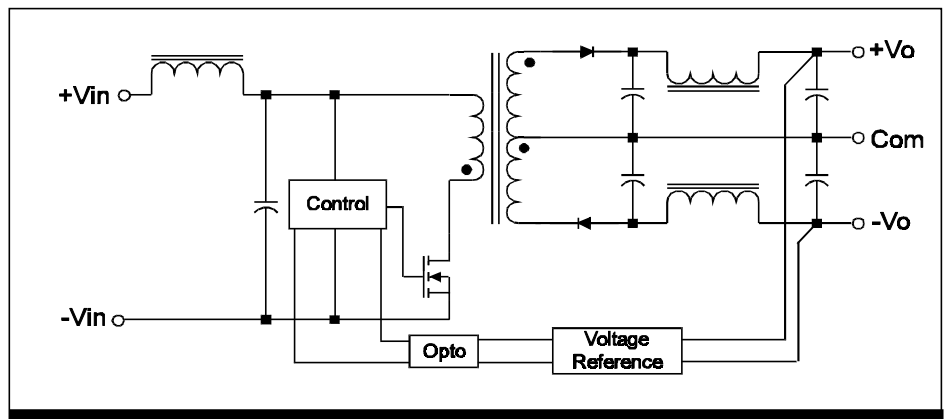

Internet: <http://www.cdpowerelectronics.com>

Power Electronics Division, United States
3400 E Britannia Drive, Tucson, Arizona 85706
Phone: 800.547.2537 Fax: 520.770.9369

Power Electronics Division, Europe
C&D Technologies (Power Electronics) Ltd.
132 Shannon Industrial Estate, Shannon, Co. Clare, Ireland
Tel: +353.61.474.133 Fax: +353.61.474.141

ABSOLUTE MAXIMUM RATINGS

Output Short Circuit Protection -----	Continuous
Internal Power Dissipation -----	1.5W
Lead Temp (soldering, 10s Max) -----	+300°C
Max Case Temperature -----	+100°C

ELECTRICAL SPECIFICATIONS

Specifications typical at $T_A=25^\circ\text{C}$, nominal input voltage, rated output current unless otherwise stated.

Model	Nominal Input Voltage (Volts)	Rated Output Voltage (Volts)	Output Current (mA)		Max Input Current (mA) Rated Load	Max Capacitive Load (μF)	Efficiency %
			Min Load	Rated Load			
WFC02R24S05	24	5.0	40	400	300	400	77
WFC02R24S12	24	12.0	16	167	306	167	76
WFC02R24S15	24	15.0	12	125	306	125	77
WFC02R24D05	24	± 5.0	± 20	± 200	315	± 200	75
WFC02R24D12	24	± 12.0	± 8	± 80	315	± 80	76
WFC02R24D15	24	± 15.0	± 7	± 67	315	± 67	76
WFC02R48S05	48	5.0	40	400	152	400	74
WFC02R48S12	48	12.0	16	167	152	167	74
WFC02R48S15	48	15.0	12	125	152	125	76
WFC02R48D05	48	± 5.0	± 20	± 200	156	± 200	74
WFC02R48D12	48	± 12.0	± 8	± 80	156	± 80	76
WFC02R48D15	48	± 15.0	± 7	± 67	155	± 67	77

ORDERING INFORMATION

	WFC02R	xyzz	E
Device Family _____			
Indicates wide input power 2W regulated DC/DC			
Model Number _____			
Selected from Table of Electrical Characteristics			
xx=input voltage			
y=number of outputs: S=single, D=dual			
zz=output voltage			
Pinout option E or L _____			

COMMON SPECIFICATIONS

Specifications typical at $T_A=25^{\circ}\text{C}$, nominal input voltage, rated output current unless otherwise stated.

Parameter	Conditions	Min	Typ	Max	Units
Input					
Voltage Range		9	24	36	Vdc
		18	48	72	Vdc
Reflected Ripple Current			50		mA p-p
Isolation					
Safety Standards	Designed to meet requirements of EN60950, EN41003 & UL1950				
Rated Voltage	"L" Pinout	1500			Vdc
	"E" Pinout	1000			Vdc
Test Voltage—60 Hz, 10 secs	"L" Pinout	1500			Vpk
	"E" Pinout	1000			Vpk
Resistance			10		$\text{G}\Omega$
Capacitance			220		pF
Leakage Current	$V_{\text{iso}}=240\text{Vac}$, 60 Hz		30		μArms
Output					
Rated Power				2	W
Voltage Setpoint Accuracy				± 3.0	%
Temperature Coefficient			± 0.02		$\%/^{\circ}\text{C}$
Line Regulation-singles	Low line to high line			$\pm 1.5\%$	%
Line Regulation-duals	Low line to high line			$\pm 1.5\%$	%
Load Regulation-singles	Min load to rated load			$\pm 2\%$	%
Load Regulation-duals	Min load to rated load			$\pm 2\%$	%
Ripple & Noise	BW=5 Hz to 20 MHz		50	100	mV p-p
General					
MTTF per MIL-HDBK-217, Rev F	$T_A=25^{\circ}$		1,000,000		Hours
Temperature					
Operation		-40		+85	$^{\circ}\text{C}$
Storage		-55		+125	$^{\circ}\text{C}$

MECHANICAL SPECIFICATIONS

PINOUT “E”

Pin Number	Pin Function	
	Singles	Duals
1	+Vin	+Vin
2	No connection	-Vout
3	No connection	Common
10	-Vout	Common
11	+Vout	+Vout
12	-Vin	-Vin
13	-Vin	-Vin
14	+Vout	+Vout
15	-Vout	Common
22	No connection	Common
23	No connection	-Vout
24	+Vin	+Vin

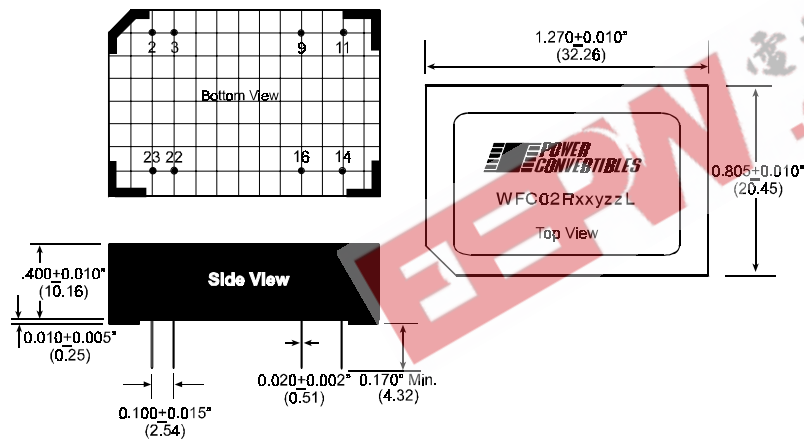
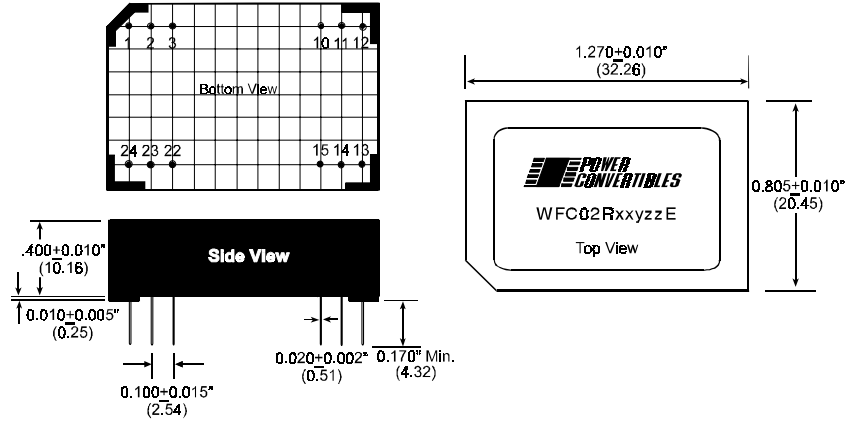

PINOUT “L”

Pin Number	Pin Function	
	Singles	Duals
2	-Vin	-Vin
3	-Vin	-Vin
9	No connection	Common
11	No connection	-Vout
14	+Vout	+Vout
16	-Vout	Common
22	+Vin	+Vin
23	+Vin	+Vin

TECHNICAL INFORMATION

Notes:

- All dimensions in inches and (millimeters).
- Units are encapsulated with a low thermal resistance molding compound which has excellent chemical resistance, wide operating temperature range and good electrical properties under high humidity environments. The encapsulant and outer shell have UL94V-0 ratings. Lead material is brass with a solder plated surface to allow ease of solderability.
- GRID: 0.100 inches, (2.54 mm).
- Pin Placement Tolerance: $\pm 0.015"$, ($\pm .381$ mm).

The information provided herein is believed to be reliable; however, C&D TECHNOLOGIES assumes no responsibility for inaccuracies or omissions. C&D TECHNOLOGIES assumes no responsibility for the use of this information, and all use of such information shall be entirely at the user's own risk. Prices and specifications are subject to change without notice. No patent rights or licenses to any of the circuits described herein are implied or granted to any third party. C&D TECHNOLOGIES does not authorize or warrant any C&D TECHNOLOGIES product for use in life support devices/systems or in aircraft control applications.