

2.50mm (0.098") PITCH CONNECTOR



Wire-to-Board
Wafer

YW025 Series

DIP

Straight

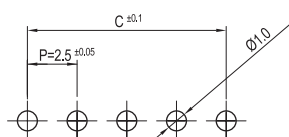
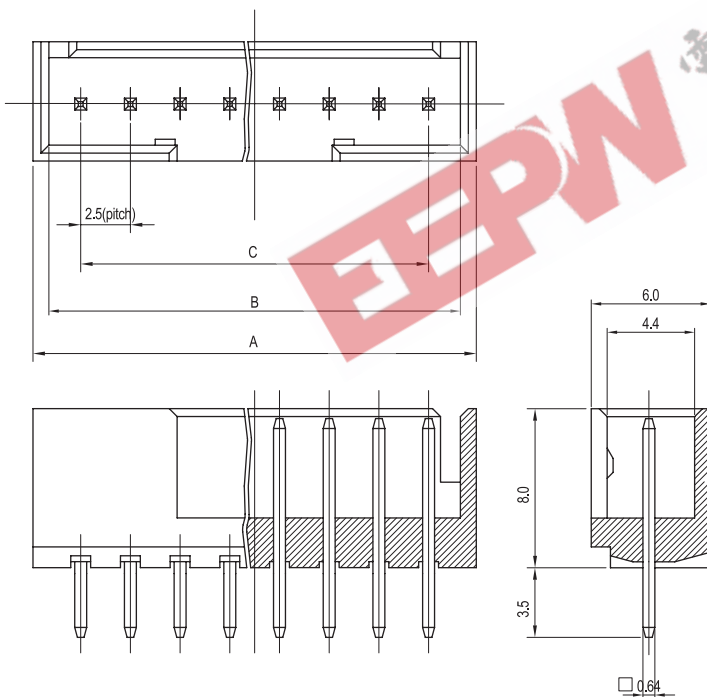
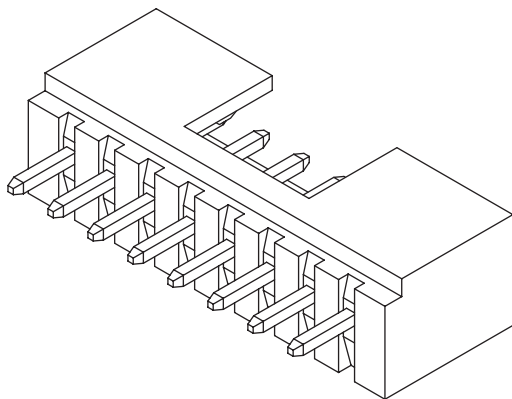

PCB LAYOUT

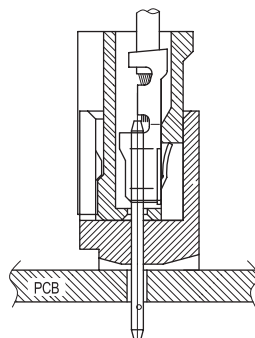

PCB ASSY

Material

I/NO	DESCRIPTION	TITLE	MATERIAL
1	WAFER	YW025	PA66, UL94 V Grade
2	PIN		Brass & Tin-Plated

Available Pin

PARTS NO.	DIM. A	DIM. B	DIM. C
YW025-02	7.3	5.7	2.5
YW025-03	9.8	8.2	5.0
YW025-04	12.3	10.7	7.5
YW025-05	14.8	13.2	10.0
YW025-06	17.3	15.7	12.5
YW025-07	19.8	18.2	15.0
YW025-08	22.3	20.7	17.5
YW025-09	24.8	23.2	20.0
YW025-10	27.3	25.7	22.5
YW025-11	29.8	28.2	25.0
YW025-12	32.3	30.7	27.5
YW025-13	34.8	33.2	30.0
YW025-14	37.3	35.7	32.5
YW025-15	39.8	38.2	35.0

Specification

ITEM	SPEC
Voltage Rating	AC/DC 250V
Current Rating	AC/DC 3A
Operating Temperature	-25℃~+85℃
Contact Resistance	30mΩ MAX
Withstanding Voltage	AC1000V/1min
Insulation Resistance	1000MΩ MIN
Applicable Wire	-
Applicable P.C.B	1.2~1.6mm
Applicable FPC/FFC	-
Solder Height	-
Crimp Tensile Strength	-
UL FILE NO	E108706