

# 2.50mm (0.098") PITCH CONNECTOR

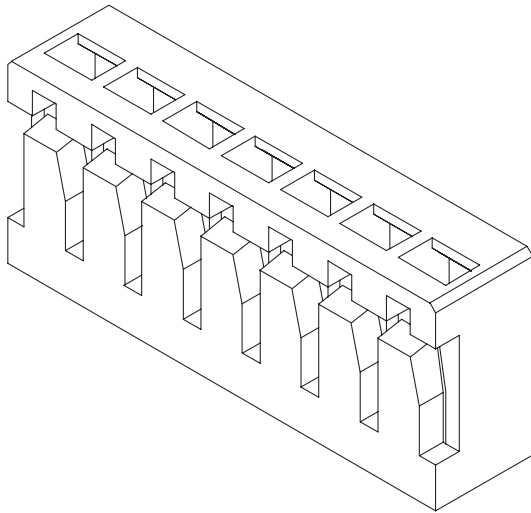

Board-In  
Housing

YBH250 Series



## Material

I/NO	DESCRIPTION	TITLE	MATERIAL
1	HOUSING	YBH250	PA66, UL94 V Grade

## Available Pin

PARTS NO.	DIM. A	DIM. B
YBH250-02	6.0	2.5
YBH250-03	8.5	5.0
YBH250-04	11.0	7.5
YBH250-05	13.5	10.0
YBH250-06	16.0	12.5
YBH250-07	18.5	15.0
YBH250-08	21.0	17.5
YBH250-09	23.5	20.0
YBH250-10	26.0	22.5
YBH250-11	28.5	25.0
YBH250-12	31.0	27.5
YBH250-13	33.5	30.0
YBH250-14	36.0	32.5
YBH250-15	38.5	35.0

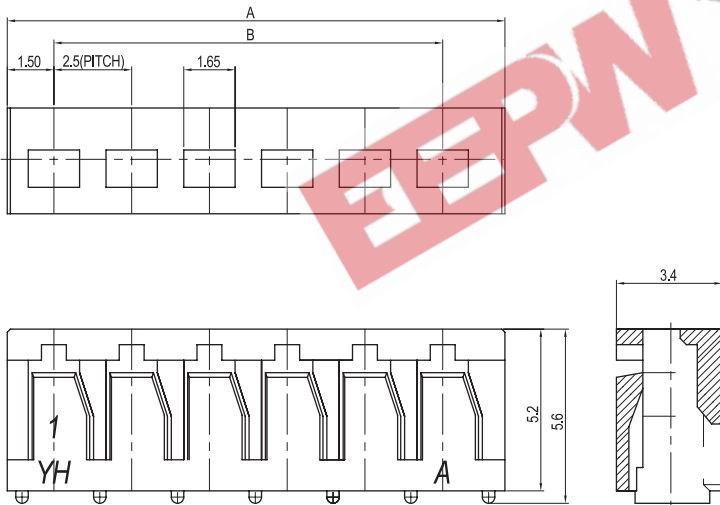

## Specification

ITEM	SPEC
Voltage Rating	AC/DC 250V
Current Rating	AC/DC 2A
Operating Temperature	-25°C~+85°C
Contact Resistance	-
Withstanding Voltage	AC1000V/1min
Insulation Resistance	1000MΩ MIN
Applicable Wire	AWG #26~#30
Applicable P.C.B	1.2~1.6mm
Applicable FPC/FFC	-
Solder Height	-
Crimp Tensile Strength	-
UL FILE NO	-

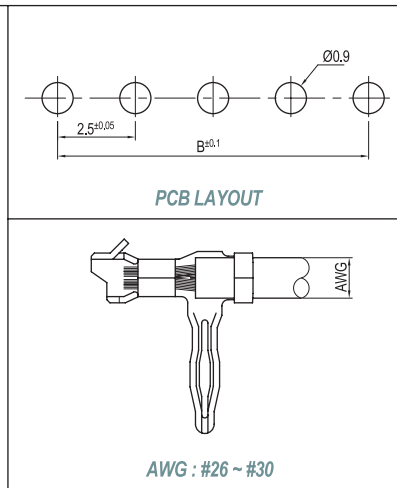
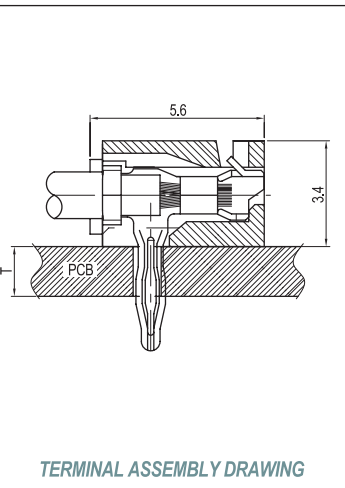

Application Terminal : YBAT200 (110 page)