

Silicon PNP Power Transistors

2SA1195

DESCRIPTION

- With TO-202 package
- High power dissipation
- Complement to type 2SC2483

APPLICATIONS

- For high voltage and general purpose amplification

PINNING(see Fig.2)

PIN	DESCRIPTION
1	Base
2	Collector
3	Emitter

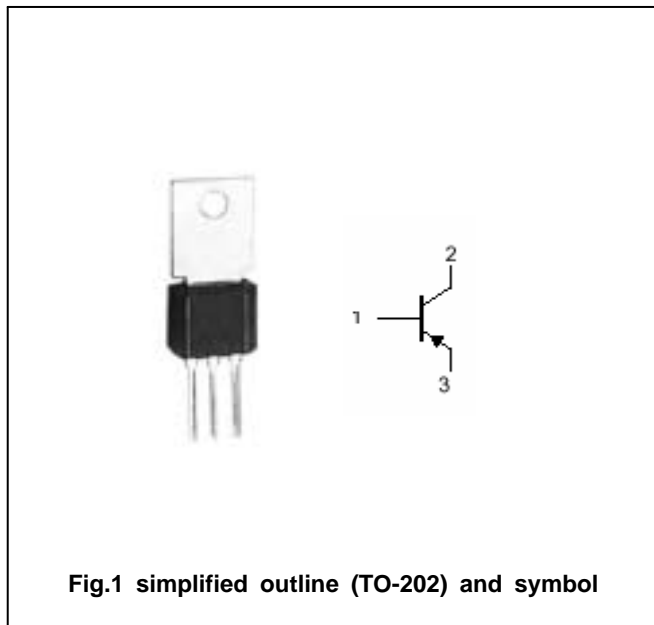

Absolute maximum ratings (Ta=25)

SYMBOL	PARAMETER	CONDITIONS	VALUE	UNIT
V_{CBO}	Collector-base voltage	Open emitter	-160	V
V_{CEO}	Collector-emitter voltage	Open base	-160	V
V_{EBO}	Emitter-base voltage	Open collector	-6	V
I_C	Collector current		-1.5	A
I_B	Base current		-0.5	A
P_C	Collector power dissipation	$T_a=25$	2	W
		$T_C=25$	15	
T_j	Junction temperature		175	
T_{stg}	Storage temperature		-55~150	

Silicon PNP Power Transistors

2SA1195

CHARACTERISTICS

T_j=25 unless otherwise specified

SYMBOL	PARAMETER	CONDITIONS	MIN	TYP.	MAX	UNIT
V _{(BR)CEO}	Collector-emitter breakdown voltage	I _C =-10mA; I _B =0	160			V
V _{CEsat}	Collector-emitter saturation voltage	I _C =-500mA; I _B =-50mA			-1.0	V
V _{BE}	Base-emitter on voltage	I _C =-5mA; V _{CE} =-5V			-0.7	V
h _{FE-1}	DC current gain	I _C =-200mA; V _{CE} =-5V	60		200	
h _{FE-2}	DC current gain	I _C =-500mA; V _{CE} =-5V	40			
I _{CBO}	Collector cut-off current	V _{CB} =-150V; I _E =0			-1	μA
I _{EBO}	Emitter cut-off current	V _{EB} =-6V; I _C =0			-1	μA
C _{OB}	Output capacitance	I _E =0; V _{CB} =-10V; f=1MHz			35	pF
f _T	Transition frequency	I _E =-100mA; V _{CB} =-5V	15	50		MHz

◆ h_{FE} classifications

R	O
60-120	100-200

Silicon PNP Power Transistors

2SA1195

PACKAGE OUTLINE

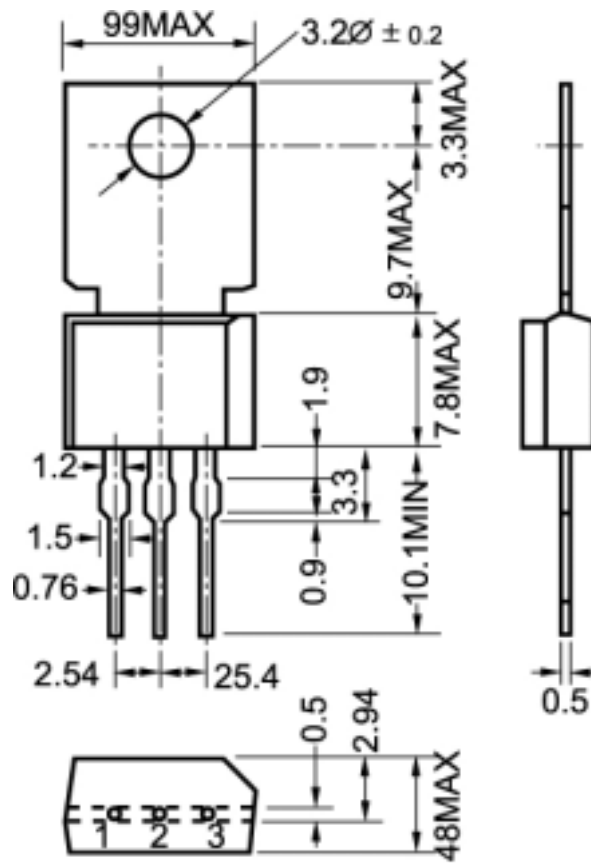

Fig.2 outline dimensions