

220-01 and 220-11 Connector Receptacle Assembly In-Line

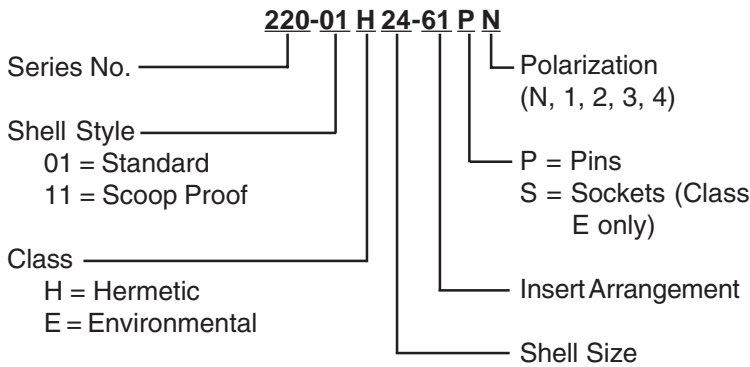
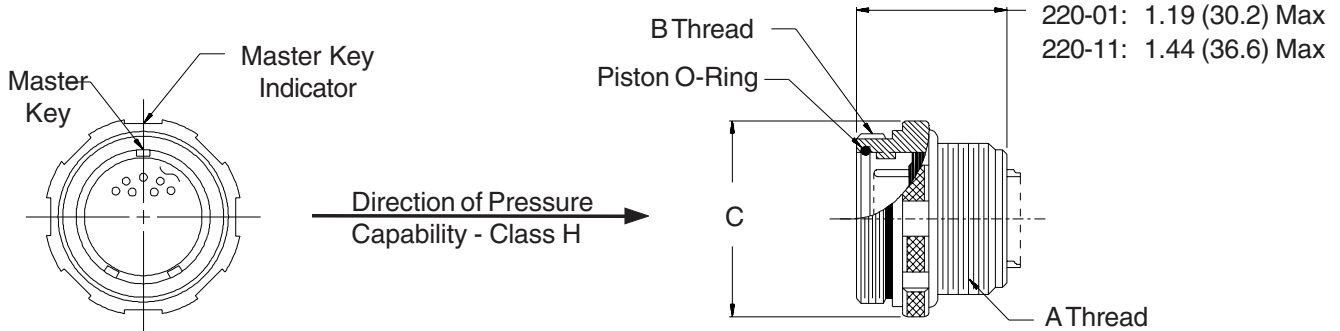

Prior to use, lubricate O-rings with high grade silicone lubricant (Moly-kote M55 or equivalent).

Metric dimensions (mm) are indicated in parentheses.

DIMENSIONS			
SHELL SIZE	A THREAD CLASS 2A	B THREAD CLASS 2A	C DIA MAX
10	5/8 - 24 UNEF	.750 - .1P - .1L	.906 (23.0)
12	3/4 - 20 UNEF	.875 - .1P - .1L	1.031 (26.2)
14	7/8 - 20 UNEF	1.000 - .1P - .1L	1.156 (29.4)
16	1 - 20 UNEF	1.125 - .1P - .1L	1.281 (32.5)
18	1 1/8 - 16 UN	1.250 - .1P - .1L	1.531 (38.9)
20	1 1/4 - 16 UN	1.375 - .1P - .1L	1.656 (42.1)
22	1 3/8 - 16 UN	1.500 - .1P - .1L	1.781 (45.2)
24	1 1/2 - 16 UN	1.625 - .1P - .1L	1.906 (48.4)

REPLACEMENT O-RING PART NUMBERS*	
SHELL SIZE	PISTON O-RING
10	2-014
12	2-016
14	2-018
16	2-020
18	2-022
20	2-024
22	2-026
24	2-028

* Parker O-ring part numbers. Compound N674-70 or equivalent.