

isc Silicon PNP Power Transistor

2SA1837

DESCRIPTION

- Collector-Emitter Breakdown Voltage-  
:  $V_{(BR)CEO} = -230V(\text{Min})$
- High Current-Gain Bandwidth Product
- Complement to Type 2SC4793

APPLICATIONS

- Power amplifier applications.
- Driver stage amplifier applications

ABSOLUTE MAXIMUM RATINGS( $T_a=25^\circ\text{C}$ )

SYMBOL	PARAMETER	VALUE	UNIT
$V_{CBO}$	Collector-Base Voltage	-230	V
$V_{CEO}$	Collector-Emitter Voltage	-230	V
$V_{EBO}$	Emitter-Base Voltage	-5	V
$I_C$	Collector Current-Continuous	-1	A
$I_B$	Base Current-Continuous	-0.1	A
$P_C$	Collector Power Dissipation @ $T_a=25^\circ\text{C}$	2	W
	Collector Power Dissipation @ $T_c=25^\circ\text{C}$	20	
$T_J$	Junction Temperature	150	$^\circ\text{C}$
$T_{stg}$	Storage Temperature	-55~150	$^\circ\text{C}$

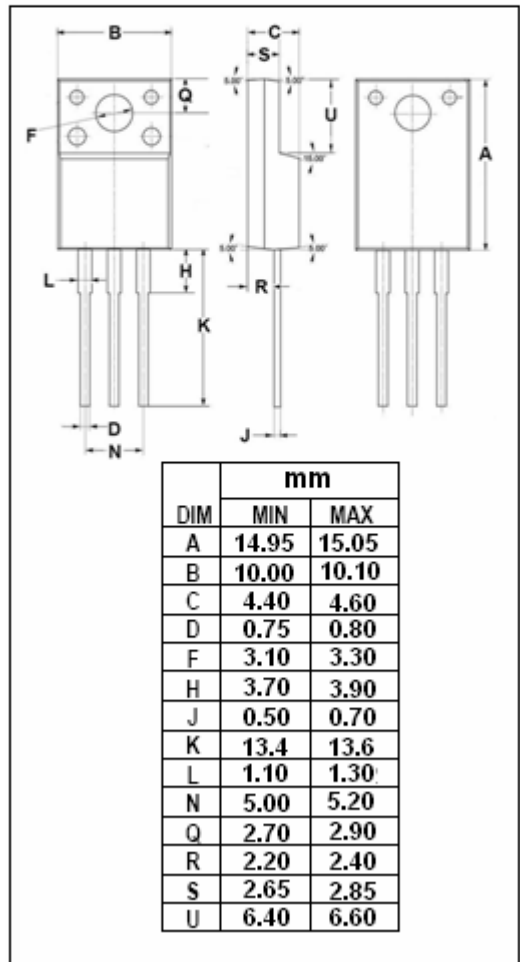
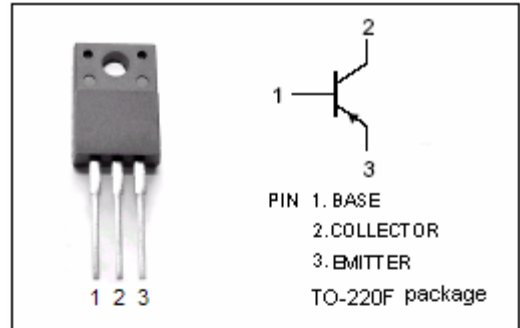

**isc Silicon PNP Power Transistor****2SA1837****ELECTRICAL CHARACTERISTICS****T<sub>j</sub>=25°C unless otherwise specified**

SYMBOL	PARAMETER	CONDITIONS	MIN	TYP.	MAX	UNIT
V <sub>(BR)CEO</sub>	Collector-Emitter Breakdown Voltage	I <sub>C</sub> = -10mA ; I <sub>B</sub> = 0	-230			V
V <sub>CE(sat)</sub>	Collector-Emitter Saturation Voltage	I <sub>C</sub> = -500mA; I <sub>B</sub> = -50mA			-1.5	V
V <sub>BE(on)</sub>	Base-Emitter On Voltage	I <sub>C</sub> = -500mA ; V <sub>CE</sub> = -5V			-1.0	V
I <sub>CBO</sub>	Collector Cutoff Current	V <sub>CB</sub> = -230V ; I <sub>E</sub> =0			-1.0	μ A
I <sub>EBO</sub>	Emitter Cutoff Current	V <sub>EB</sub> = -5V; I <sub>C</sub> =0			-1.0	μ A
h <sub>FE</sub>	DC Current Gain	I <sub>C</sub> = -100mA; V <sub>CE</sub> = -5V	100		320	
C <sub>OB</sub>	Output Capacitance	I <sub>E</sub> = 0; V <sub>CB</sub> = -10V; f= 1MHz		30		pF
f <sub>T</sub>	Current-Gain—Bandwidth Product	I <sub>C</sub> = -100mA ; V <sub>CE</sub> = -10V		70		MHz