

# 232-103-H7 Jam Nut Mount Hermetic Bulkhead Feed-Thru MIL-DTL-38999 Series II Type

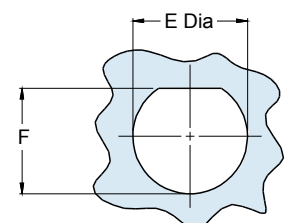

Bulkhead  
Feed-Thru

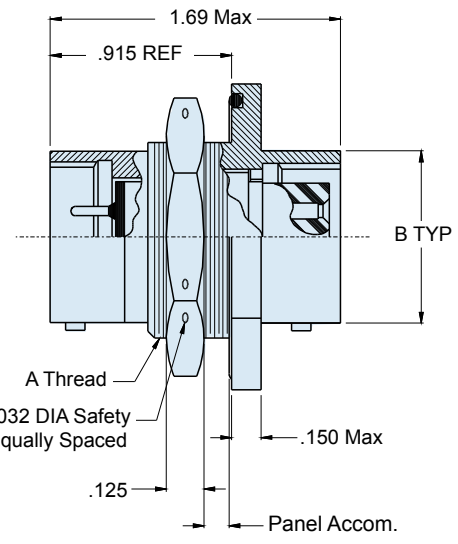
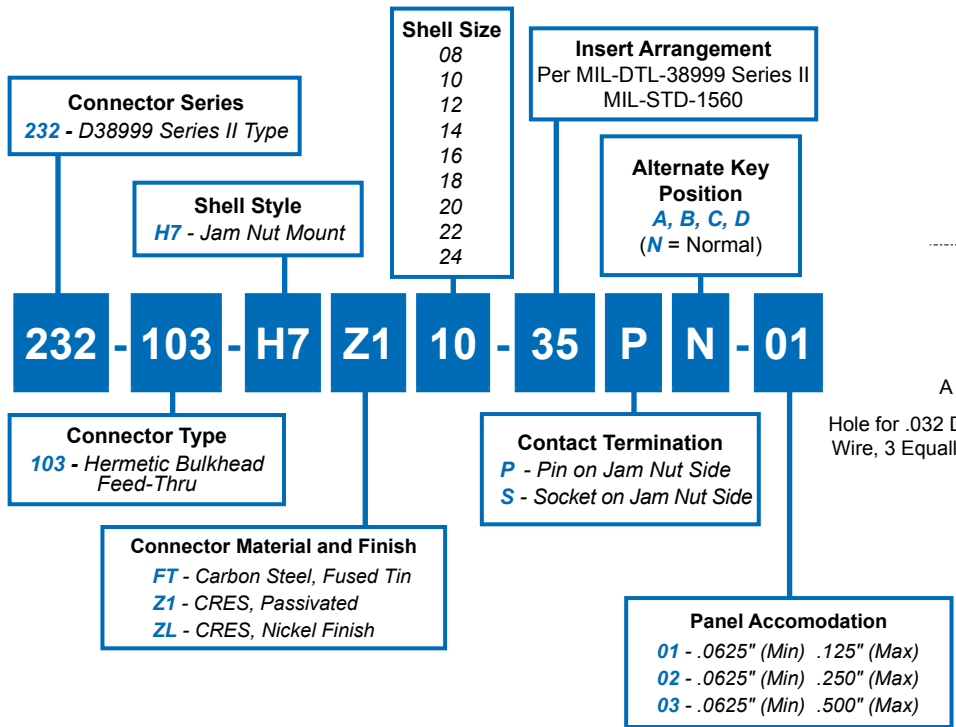

Recommended Panel Cut-Out

SHELL SIZE	A THREAD CLASS 2A	B DIA MAX	C HEX	D FLATS	E DIA ±.005(0.1)	F +.000-.005 (0-0.1)
08	.875-20 UNEF	.474(12.0)	1.062(27.0)	1.250(31.8)	.885(22.5)	.830(21.1)
10	1.000-20 UNEF	.591(15.0)	1.188(30.2)	1.375(34.9)	1.010(25.7)	.955(24.3)
12	1.125-18 UNEF	.751(19.1)	1.312(33.3)	1.500(38.1)	1.135(28.8)	1.085(27.6)
14	1.250-18 UNEF	.876(22.3)	1.438(36.5)	1.625(41.3)	1.260(32.0)	1.210(30.7)
16	1.375-18 UNEF	1.001(25.4)	1.562(39.7)	1.781(45.2)	1.385(35.2)	1.335(33.9)
18	1.500-18 UNEF	1.126(28.6)	1.688(42.9)	1.890(48.0)	1.510(38.4)	1.460(37.1)
20	1.625-18 UNEF	1.251(31.8)	1.812(46.0)	2.016(51.2)	1.635(41.5)	1.585(40.3)
22	1.750-18 UNS	1.376(35.0)	2.000(50.8)	2.140(54.4)	1.760(44.7)	1.710(43.4)
24	1.875-16 UN	1.501(38.1)	2.125(54.0)	2.265(57.5)	1.885(47.9)	1.835(46.6)

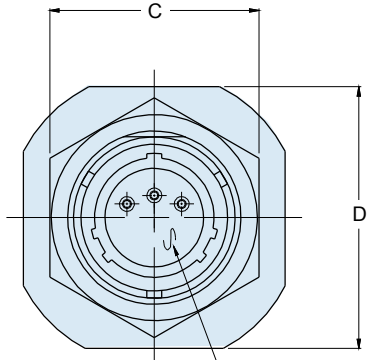

Insert Arrangement per MIL-DTL-38999, Series II MIL-STD-1560

1. Power to a given contact on one end will result in power to contact directly opposite, regardless of identification letter.	Contacts – Gold Plated. Pin: alloy 52; Skt.: copper alloy
2. Hermeticity = less than 1 x 10 <sup>-4</sup> cc/sec at one atmosphere. Not for use in liquid atmosphere.	Insulator – fused vitreous glass/N.A.
3. Material/finish: Shell, nut – CRES/passivated, carbon steel/fused tin or CRES/nickel per QQ-N-290.	Seals – fluorosilicone rubber/N.A.
	4. Metric dimensions (mm) are indicated in parentheses.