

Silicon PNP Power Transistors

2SA814 2SA815

DESCRIPTION

- With TO-220 package
- Complement to type 2SC1624/1625
- High breakdown voltage

APPLICATIONS

- Medium power amplifier applications
- Driver stage amplifier applications

PINNING

PIN	DESCRIPTION
1	Emitter
2	Collector;connected to mounting base
3	Base

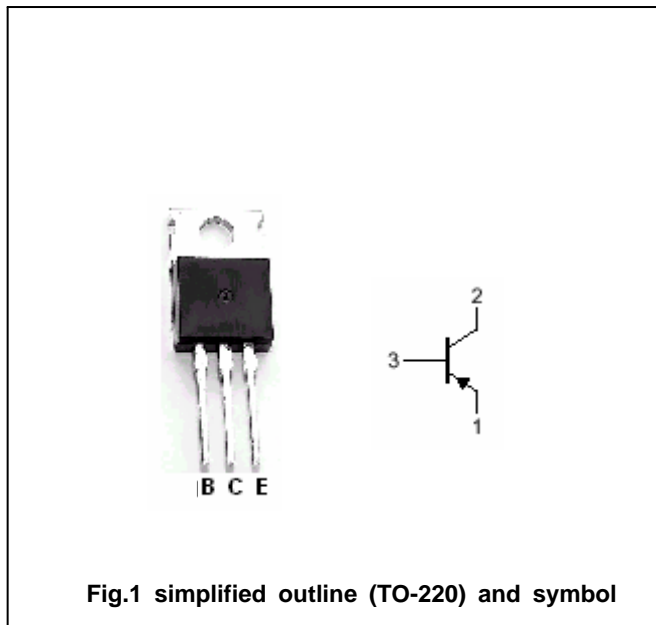

Absolute maximum ratings(Ta=25)

SYMBOL	PARAMETER	CONDITIONS	VALUE	UNIT
V _{CBO}	Collector-base voltage	2SA814	-120	V
		2SA815	-100	
V _{CEO}	Collector-emitter voltage	2SA814	-120	V
		2SA815	-100	
V _{EBO}	Emitter-base voltage	Open collector	-5	V
I _C	Collector current		-1	A
I _E	Emitter current		1	A
P _C	Collector power dissipation	T _C =25	15	W
T _j	Junction temperature		150	
T _{stg}	Storage temperature		-55~150	

Silicon PNP Power Transistors

2SA814 2SA815

CHARACTERISTICS

T_j=25 unless otherwise specified

SYMBOL	PARAMETER	CONDITIONS	MIN	TYP.	MAX	UNIT
V _{(BR)CEO}	Collector-emitter breakdown voltage	2SA814	-120			V
		2SA815	-100			
V _{(BR)EBO}	Emitter-base breakdown voltage	I _E =-1.0mA, I _C =0	-5			V
V _{CEsat}	Collector-emitter saturation voltage	I _C =-500mA; I _B =-50mA			-0.5	V
V _{BE}	Base-emitter on voltage	I _C =-500mA; V _{CE} =-5V			-1.0	V
I _{CBO}	Collector cut-off current	V _{CB} =-50V; I _E =0			-1.0	μA
I _{EBO}	Emitter cut-off current	V _{EB} =-5V; I _C =0			-1.0	μA
h _{FE-1}	DC current gain	I _C =-150mA; V _{CE} =-5V	70		240	
h _{FE-2}	DC current gain	I _C =-500mA; V _{CE} =-5V	40			
C _{OB}	Collector output capacitance	I _E =0; V _{CB} =-10V; f=1MHz		30		pF
f _T	Transition frequency	I _C =-150mA; V _{CE} =-5V	10	30		MHz

◆ h_{FE-1} Classifications

O	Y
70-140	120-240

Silicon PNP Power Transistors

2SA814 2SA815

PACKAGE OUTLINE

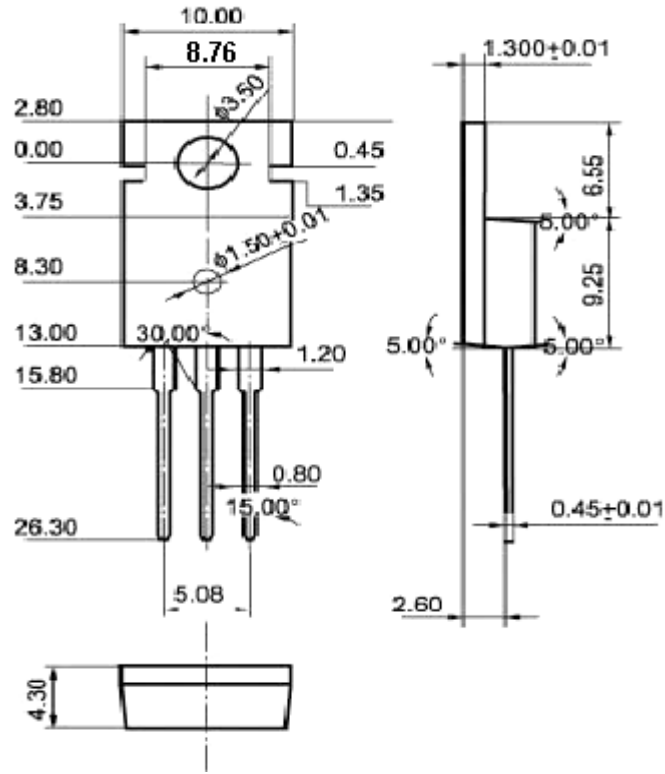

Fig.2 Outline dimensions(unindicated tolerance: ± 0.10 mm)