

SILICON PNP TRANSISTOR

DESCRIPTION:

The **2N2905A** is Designed for General Purpose Amplifier and Switching Applications

MAXIMUM RATINGS

I_C	600 mA
V_{CE}	-60 V
P_{DISS}	3.0 W @ $T_C = 25^\circ C$
T_J	-65 °C to +200 °C
T_{STG}	-65 °C to +200 °C
θ_{JC}	58 °C/W

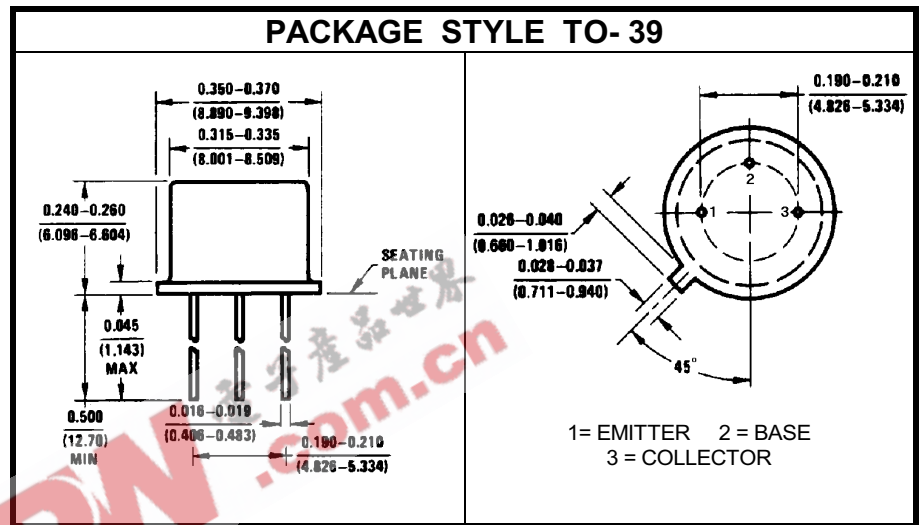
CHARACTERISTICS $T_C = 25^\circ C$

SYMBOL	TEST CONDITIONS	MINIMUM	TYPICAL	MAXIMUM	UNITS
BV_{CEO}	$I_C = 10\text{ mA}$	-60			V
BV_{CBO}	$I_C = 10\text{ }\mu\text{A}$	-60			V
I_{CBO}	$V_{CB} = -50\text{ V}$			0.01 10	μA
I_{CEX}	$V_{CE} = -30\text{ V}$ $V_{BE} = 0.5\text{ V}$			50	nA
I_B	$V_{CE} = -30\text{ V}$ $V_{BE} = 0.5\text{ V}$			50	nA
BV_{EBO}	$I_E = 10\text{ }\mu\text{A}$	-5.0			V
h_{FE}	$V_{CE} = -10\text{ V}$ $I_C = 100\text{ }\mu\text{A}$ $I_C = 1.0\text{ mA}$ $I_C = 10\text{ mA}$ $I_C = 150\text{ mA}$ $I_C = 500\text{ mA}$	75 100 100 100 50	300		---
$V_{CE(SAT)}$	$I_C = 150\text{ mA}$ $I_B = 15\text{ mA}$ $I_C = 500\text{ mA}$ $I_B = 50\text{ mA}$			-0.4 -1.6	V
$V_{BE(SAT)}$	$I_C = 150\text{ mA}$ $I_B = 15\text{ mA}$ $I_C = 500\text{ mA}$ $I_B = 50\text{ mA}$			-1.3 -2.6	V

**DYNAMIC CHARACTERISTICS** $T_c = 25^\circ\text{C}$

SYMBOL	TEST CONDITIONS	MINIMUM	TYPICAL	MAXIMUM	UNITS
f_t	$V_{CE} = -20\text{ V}$ $I_C = 50\text{ mA}$ $f = 100\text{ MHz}$	200			MHz
C_{ob}	$V_{CB} = -10\text{ V}$ $f = 100\text{ KHz}$			8.0	pF
C_{ib}	$V_{EB} = -2.0\text{ V}$ $f = 100\text{ KHz}$			30	pF
t_{on}	$V_{CC} = -30\text{ V}$ $I_C = 150\text{ mA}$ $I_{B1} = 15\text{ mA}$			45	nS
t_d	$V_{CC} = -30\text{ V}$ $I_C = 150\text{ mA}$ $I_{B1} = 15\text{ mA}$			10	nS
t_r	$V_{CC} = -30\text{ V}$ $I_C = 150\text{ mA}$ $I_{B1} = 15\text{ mA}$			40	nS
t_{off}	$V_{CC} = -6.0\text{ V}$ $I_C = 150\text{ mA}$, $I_{B1} = I_{B2} = 15\text{ mA}$			100	nS
t_s	$V_{CC} = -6.0\text{ V}$ $I_C = 150\text{ mA}$, $I_{B1} = I_{B2} = 15\text{ mA}$			80	nS
t_f	$V_{CC} = -6.0\text{ V}$ $I_C = 150\text{ mA}$, $I_{B1} = I_{B2} = 15\text{ mA}$			30	nS

EEPW.com.cn 电子产品世界