

**PNP SILICON PLANAR SWITCHING TRANSISTORS**

**2N2904A  
2N2905A  
TO-39**

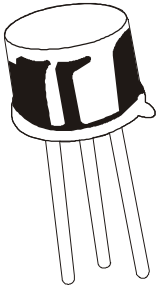

**Switching And Linear Application DC to VHF Amplifier Applications**

**ABSOLUTE MAXIMUM RATINGS**

DESCRIPTION	SYMBOL	2N2904A, 05A	UNIT
Collector -Emitter Voltage	VCEO	60	V
Collector -Base Voltage	VCBO	60	V
Emitter -Base Voltage	VEBO	5.0	V
Collector Current Continuous	IC	600	mA
Power Dissipation @Ta=25 degC	PD	600	mW
Derate Above 25deg C		3.43	mW/deg C
@ Tc=25 degC	PD	3.0	W
Derate Above 25deg C		17.2	mW/deg C
Operating And Storage Junction Temperature Range	Tj, Tstg	-65 to +200	deg C

**ELECTRICAL CHARACTERISTICS (Ta=25 deg C Unless Otherwise Specified)**

DESCRIPTION	SYMBOL	TEST CONDITION	VALUE		UNIT
			MIN	MAX	
Collector -Emitter Voltage	VCEO*	IC=10mA, IB=0	60	-	V
Collector -Base Voltage	VCBO	IC=10uA, IE=0	60	-	V
Emitter-Base Voltage	VEBO	IE=10uA, IC=0	5.0	-	V
Collector-Cut off Current	ICBO	VCB=50V, IE=0	-	10	nA
Base Current	ICEX	Ta=150 deg C	-	10	uA
		VCB=50V, IE=0	-	50	nA
		VCE=30V, VBE=0.5V	-	50	nA
Collector Emitter Saturation Voltage	VCE(Sat)*	IC=150mA, IB=15mA	-	0.4	V
		IC=500mA, IB=50mA	-	1.6	V
Base Emitter Saturation Voltage	VBE(Sat) *	IC=150mA, IB=15mA	-	1.3	V
		IC=500mA, IB=50mA	-	2.6	V
DC Current Gain	hFE	IC=0.1mA, VCE=10V	<u>2N2904A</u>	<u>2N2905A</u>	
			>40	>75	
		IC=1mA, VCE=10V	>40	>100	
		IC=10mA, VCE=10V	>40	>100	
		IC=150mA, VCE=10V*	40-120	100-300	
		IC=500mA, VCE=10V*	>40	>50	

**ELECTRICAL CHARACTERISTICS (Ta=25 deg C Unless Otherwise Specified)**

**2N2904A-05A**

DESCRIPTION	SYMBOL	TEST CONDITION	MIN	MAX	UNIT
<b><u>DYNAMIC CHARACTERISTICS</u></b>					
Transition Frequency	ft **	IC=50mA, VCE=20V, f=100MHz	200	-	MHz
Out-Put Capacitance	Cob	VCB=10V, IE=0, f=100kHz	-	8.0	pF
Input Capacitance	Cib	VBE=2V, IC=0, f=100kHz	-	30	pF
<b><u>Switching Time</u></b>					
Delay time	td	IC=150mA, IB1=15mA	-	10	ns
Rise time	tr	VCC=30V	-	40	ns
Turn-On Time	ton			45	ns
Storage time	ts	IC=150mA, IB1=IB2=15mA	-	80	ns
Fall time	tf	VCC=6V	-	30	ns
Turn-Off Time	toff		-	100	ns

\*Pulse Test :-Pulse Width=300us, Duty Cycle=2%

\*\*ft is defined as the frequency at which  $h_{fe}$  extrapolates to unity

**TO-39 Metal Can Package**

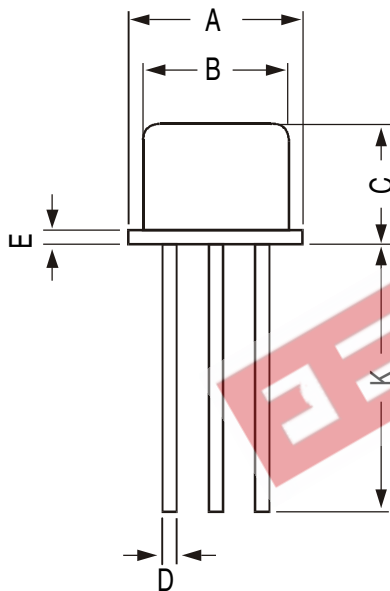

DIM	MIN	MAX
A	8.50	9.39
B	7.74	8.50
C	6.09	6.60
D	0.40	0.53
E	—	0.88
F	2.41	2.66
G	4.82	5.33
H	0.71	0.86
J	0.73	1.02
K	12.70	—
L	42 DEG	48 DEG

All dimensions are in mm

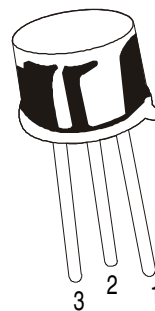
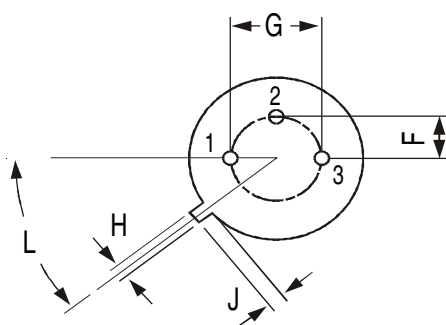

**PIN CONFIGURATION**

1. EMITTER
2. BASE
3. COLLECTOR

**Packing Detail**

PACKAGE	STANDARD PACK		INNER CARTON BOX		OUTER CARTON BOX		
	Details	Net Weight/Qty	Size	Qty	Size	Qty	Gr Wt
TO-39	500 pcs/polybag	540 gm/500 pcs	3" x 7.5" x 7.5"	20.0K	17" x 15" x 13.5"	32.0K	40 kgs