

GENERAL PURPOSE AMPLIFIERS AND SWITCHES

DESCRIPTION

The 2N2905A and 2N2907A are silicon planar epitaxial PNP transistors in Jedec TO-39 (for 2N2905A) and in Jedec TO-18 (for 2N2907A) metal case. They are designed for high speed saturated switching and general purpose applications.

- 2N2905A approved to CECC 50002-100, 2N2906A approved to CECC 50002-103 available on request.

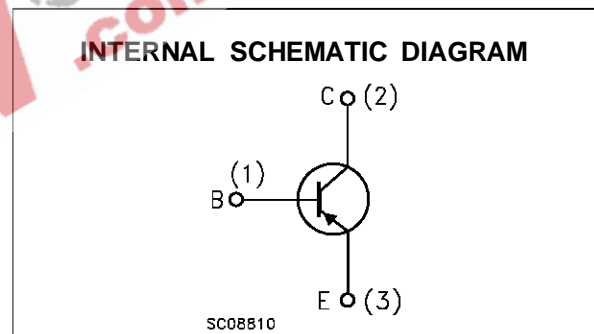
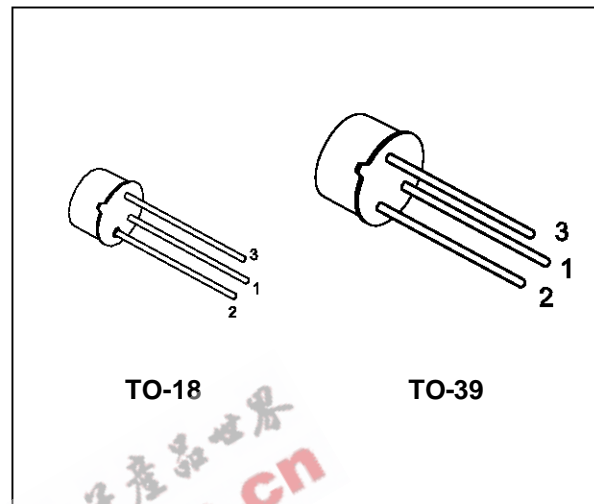

ABSOLUTE MAXIMUM RATINGS

Symbol	Parameter	Value	Unit
V_{CBO}	Collector-Base Voltage ($I_E = 0$)	-60	V
V_{CEO}	Collector-Emitter Voltage ($I_B = 0$)	-60	V
V_{EBO}	Emitter-Base Voltage ($I_C = 0$)	-5	V
I_C	Collector Current	-0.6	A
P_{tot}	Total Dissipation at $T_{amb} \leq 25\text{ }^\circ\text{C}$ for 2N2905A for 2N2907A at $T_{case} \leq 25\text{ }^\circ\text{C}$ for 2N2905A for 2N2907A	0.6	W
		0.4	W
		3	W
		1.8	W
T_{stg}	Storage Temperature	-65 to 200	$^\circ\text{C}$
T_j	Max. Operating Junction Temperature	200	$^\circ\text{C}$

2N2905A/2N2907A

THERMAL DATA

			TO-39	TO-18	
R _{thj-case}	Thermal Resistance Junction-Case	Max	58.3	97.3	°C/W
R _{thj-amb}	Thermal Resistance Junction-Ambient	Max	292	437.5	°C/W

ELECTRICAL CHARACTERISTICS (T_{case} = 25 °C unless otherwise specified)

Symbol	Parameter	Test Conditions	Min.	Typ.	Max.	Unit
I _{CBO}	Collector Cut-off Current (I _E = 0)	V _{CB} = -50 V V _{CB} = -50 V T _{case} = 150 °C			-10 -10	nA μA
I _{CEX}	Collector Cut-off Current (V _{BE} = -0.5V)	V _{CE} = -30 V			-50	nA
I _{BEX}	Base Cut-off Current (V _{BE} = -0.5V)	V _{CE} = -30 V			-50	nA
V _{(BR)CBO} *	Collector-Base Breakdown Voltage (I _E = 0)	I _C = -10 μA	-60			V
V _{(BR)CEO} *	Collector-Emitter Breakdown Voltage (I _B = 0)	I _C = -10 mA	-60			V
V _{(BR)EBO} *	Emitter-Base Breakdown Voltage (I _C = 0)	I _E = -10 μA	-5			V
V _{CE(sat)} *	Collector-Emitter Saturation Voltage	I _C = -150 mA I _B = -15 mA I _C = -500 mA I _B = -50 mA			-0.4 -1.6	V V
V _{BE(sat)} *	Base-Emitter Saturation Voltage	I _C = -150 mA I _B = -15 mA I _C = -500 mA I _B = -50 mA			-1.3 -2.6	V V
h _{FE} *	DC Current Gain	I _C = -0.1 mA V _{CE} = -10 V I _C = -1 mA V _{CE} = -10 V I _C = -10 mA V _{CE} = -10 V I _C = -150 mA V _{CE} = -10 V I _C = -500 mA V _{CE} = -10 V	75 100 100 100 50		300	
f _T	Transition Frequency	V _{CE} = -50 V f = 100 MHz I _C = -20 mA	200			MHz
C _{EBO}	Emitter Base Capacitance	I _C = 0 V _{EB} = -2 V f = 1MHz			30	pF
C _{CBO}	Collector Base Capacitance	I _E = 0 V _{CB} = -10 V f = 1MHz			8	pF
t _d **	Delay Time	V _{CC} = -30 V I _C = -150 mA I _{B1} = -15 mA			10	ns
t _r **	Rise Time	V _{CC} = -30 V I _C = -150 mA I _{B1} = -15 mA			40	ns
t _s **	Storage Time	V _{CC} = -6 V I _C = -150 mA I _{B1} = -I _{B2} = -15 mA			80	ns
t _f **	Fall Time	V _{CC} = -6 V I _C = -150 mA I _{B1} = -I _{B2} = -15 mA			30	ns
t _{on} **	Turn-on Time	V _{CC} = -30 V I _C = -150 mA I _{B1} = -15 mA			45	ns
t _{off} **	Turn-off Time	V _{CC} = -6 V I _C = -150 mA I _{B1} = -I _{B2} = -15 mA			100	ns

* Pulsed: Pulse duration = 300 μs, duty cycle ≤ 1 %

** See test circuit

Normalized DC Current Gain.

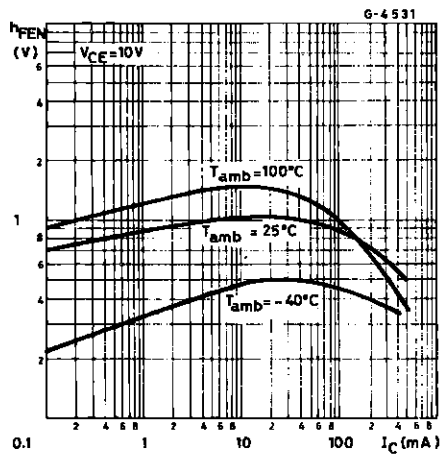

Collector-emitter Saturation Voltage.

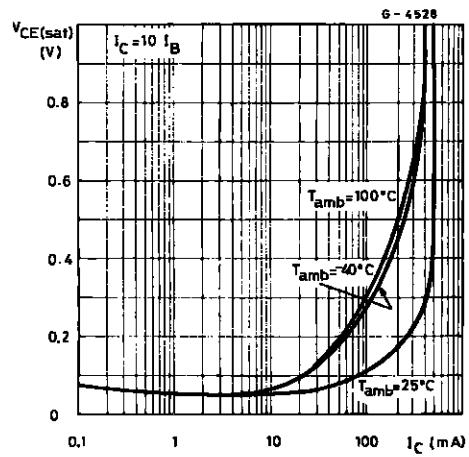

Collector-base and Emitter-base capacitances.

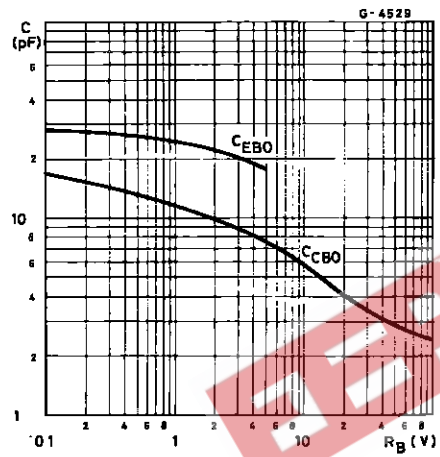

Switching Characteristics.

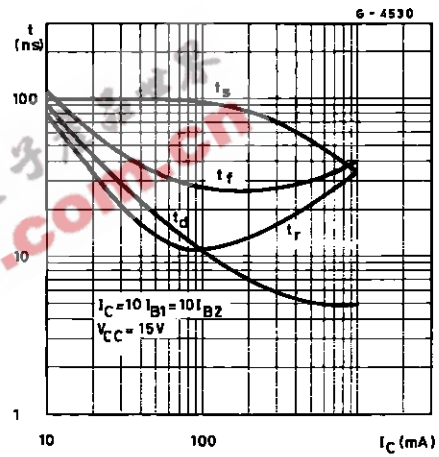

2N2905A/2N2907A

Test Circuit for t_{on} , t_r , t_d .

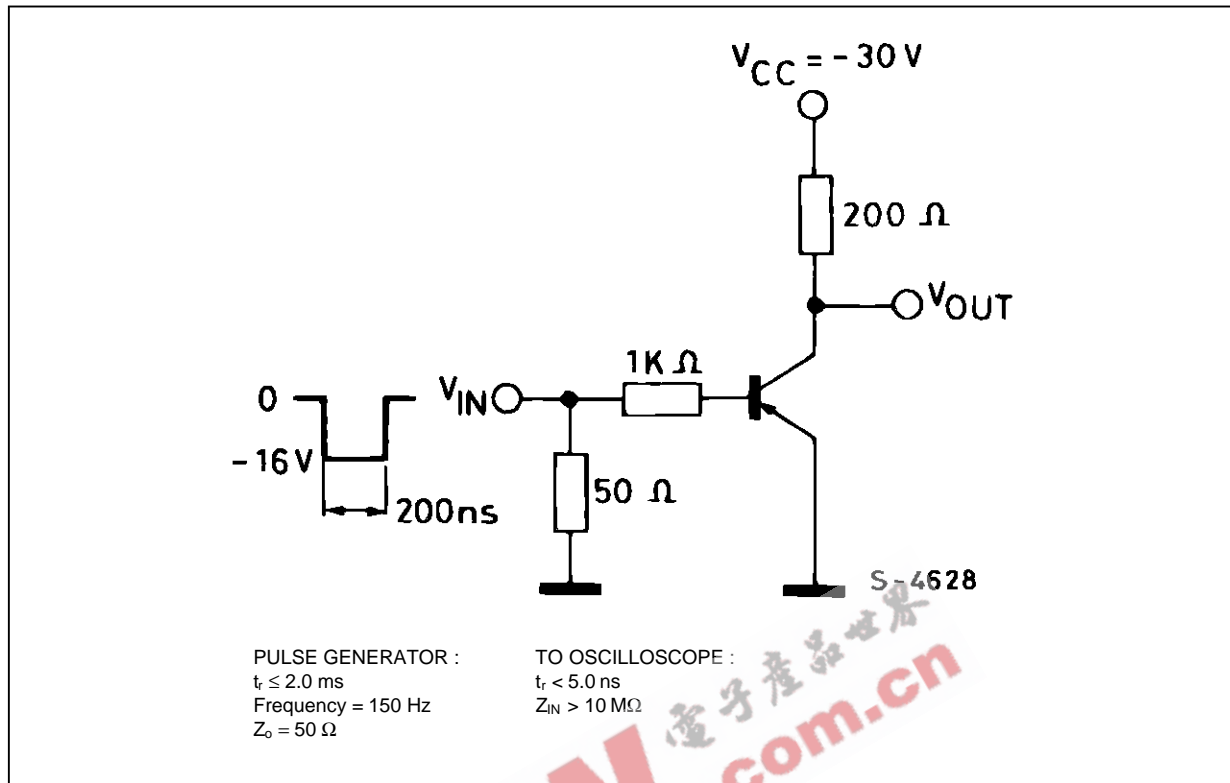

Test Circuit for t_{off} , t_o , t_f .

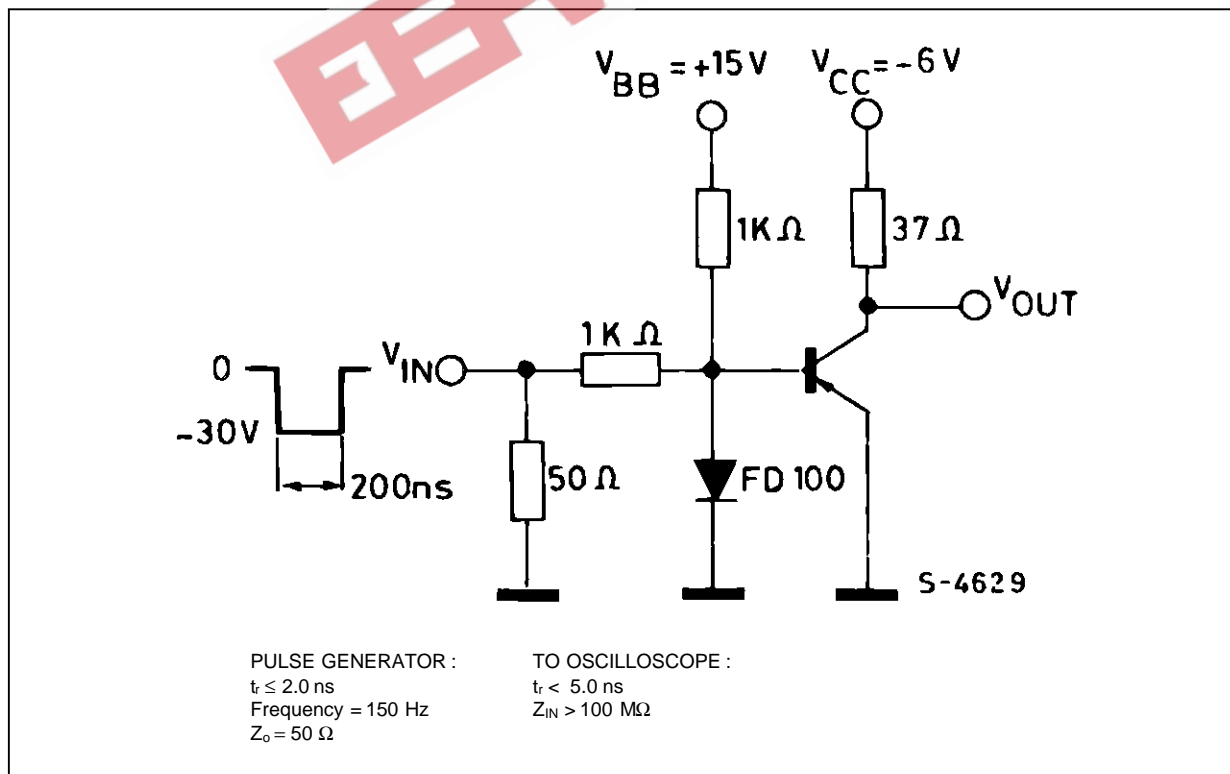

TO-18 MECHANICAL DATA

DIM.	mm			inch		
	MIN.	TYP.	MAX.	MIN.	TYP.	MAX.
A		12.7			0.500	
B			0.49			0.019
D			5.3			0.208
E			4.9			0.193
F			5.8			0.228
G	2.54			0.100		
H			1.2			0.047
I			1.16			0.045
L	45°			45°		

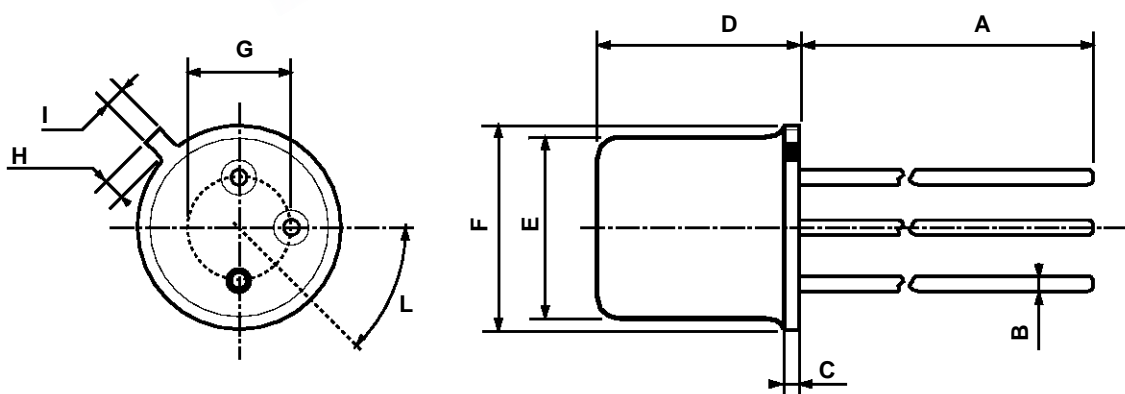

0016043

TO-39 MECHANICAL DATA

DIM.	mm			inch		
	MIN.	TYP.	MAX.	MIN.	TYP.	MAX.
A	12.7			0.500		
B			0.49			0.019
D			6.6			0.260
E			8.5			0.334
F			9.4			0.370
G	5.08			0.200		
H			1.2			0.047
I			0.9			0.035
L	45° (typ.)					

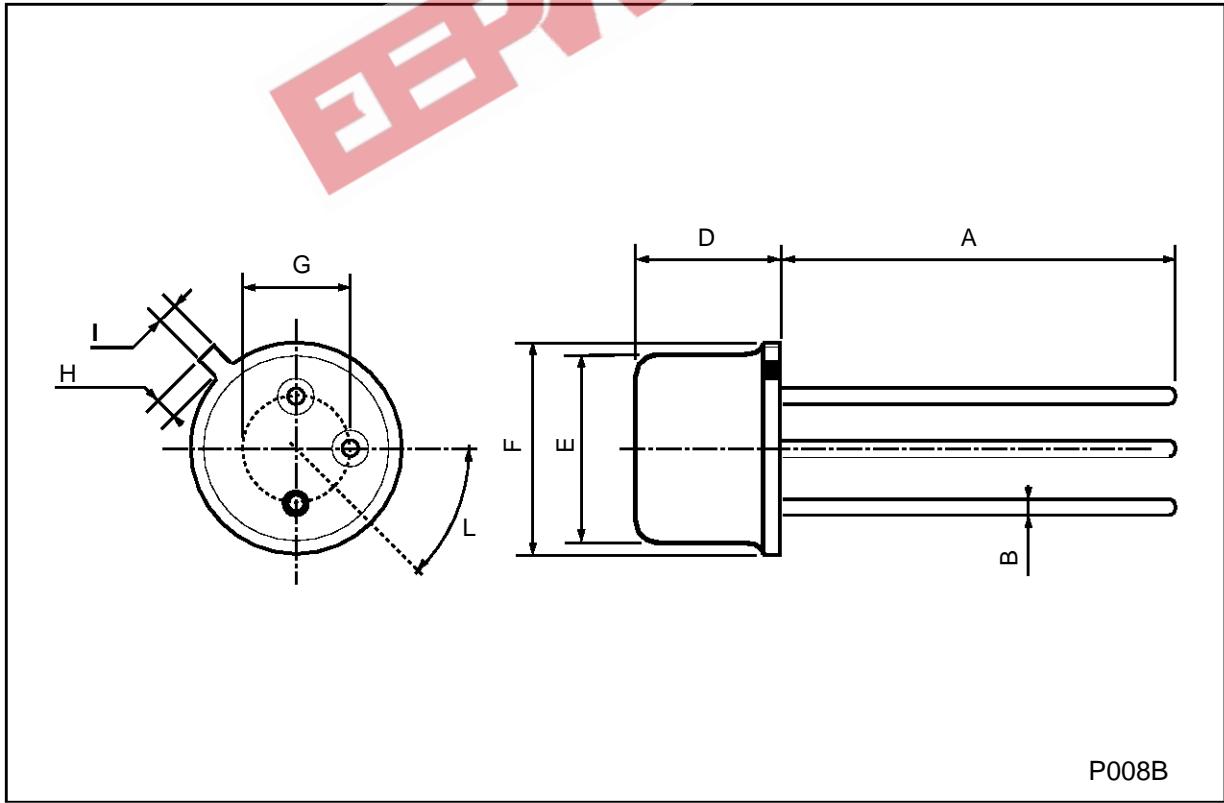

EEPW 电子产品世界
.com.cn

Information furnished is believed to be accurate and reliable. However, SGS-THOMSON Microelectronics assumes no responsibility for the consequences of use of such information nor for any infringement of patents or other rights of third parties which may result from its use. No license is granted by implication or otherwise under any patent or patent rights of SGS-THOMSON Microelectronics. Specifications mentioned in this publication are subject to change without notice. This publication supersedes and replaces all information previously supplied. SGS-THOMSON Microelectronics products are not authorized for use as critical components in life support devices or systems without express written approval of SGS-THOMSON Microelectronics.

© 1997 SGS-THOMSON Microelectronics - Printed in Italy - All Rights Reserved

SGS-THOMSON Microelectronics GROUP OF COMPANIES

Australia - Brazil - Canada - China - France - Germany - Italy - Japan - Korea - Malaysia - Malta - Morocco - The Netherlands -
Singapore - Spain - Sweden - Switzerland - Taiwan - Thailand - United Kingdom - U.S.A

...