

2N3583

APPLICATIONS:

- Off-Line Inverters
- Switching Regulators
- Motor Controls
- Deflection Circuits
- DC-DC Converters
- High Voltage Amplifiers

FEATURES:

- High Voltage: 250 to 500V
- Fast Switching: $t_f < 3\mu\text{sec.}$
- High Power: 35 Watts
- High Current: 2 Amps
- LOW $V_{CE(SAT)}$

**5 Amp, 250V,
 High Voltage
 NPN Silicon Power
 Transistors**

DESCRIPTION:

These power transistors are produced by PPC's DOUBLE DIFFUSED PLANAR process. This technology produces high voltage devices with excellent switching speeds, frequency response, gain linearity, saturation voltages, high current gain, and safe operating areas. They are intended for use in Commercial, Industrial, and Military power switching, amplifier, and regulator applications.

Ultrasonically bonded leads and controlled die mount techniques are utilized to further increase the SOA capability and inherent reliability of these devices. The temperature range to 200°C permits reliable operation in high ambients, and the hermetically sealed package insures maximum reliability and long life.

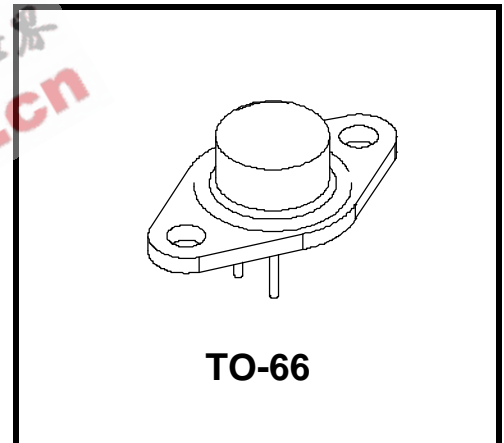

ABSOLUTE MAXIMUM RATINGS:

SYMBOL	CHARACTERISTIC	VALUE	UNITS
V_{CBO}^*	Collector-Base Voltage	250	Volts
V_{CEO}^*	Collector-Emitter Voltage	175	Volts
V_{CER}^*	Collector-Emitter Voltage $R_{BE} = 50\Omega$	250	Volts
V_{EBO}^*	Emitter-Base Voltage	6	Volts
I_C^*	Peak Collector Current	5	Amps
I_C^*	Continuous Collector Current	1	Amps
I_B^*	Base Current	1	Amps
T_{STG}^*	Storage Temperature	-65 to 200	°C
T_J^*	Operating Junction Temperature	-65 to 200	°C
*	Lead Temperature 1/16" from Case for 10 Sec.	235	°C
P_T^*	Power Dissipation $T_C = 25^\circ\text{C}$	35	Watts
θ_{JC}	Thermal Impedance	5.0	°C/W

* Indicates JEDEC registered data.

**ELECTRICAL CHARACTERISTICS:
 (25° Case Temperature Unless Otherwise Noted)**

SYMBOL	CHARACTERISTIC	TEST CONDITIONS	VALUE		Units
			Min.	Max.	
$V_{CEO(sus)}^*$	Collector-Emitter Sustaining Voltage	$I_C = 0.2 \text{ Amp}$ (Notes 1 and 2)	175	----	Volts
$V_{CER(sus)}$	Collector-Emitter Sustaining Voltage	$I_C = 0.2A, R_{BE} = 50\Omega$ (Notes 1 and 2)	250	----	Volts
I_{CEV}^*	Collector Cutoff Current	$V_{CE} = 225V, V_{BE} = -1.5V$	----	1.0	mA.
I_{CEV}^*	Collector Cutoff Current	$V_{CE} = 225V, V_{BE} = -1.5V$ $T_C = 150^\circ C$	----	3.0	mA.
I_{CEO}^*	Collector Cutoff Current	$V_{CE} = 150V, I_B = 0$	----	10	mA.
I_{EB0}^*	Emitter Cutoff Current	$V_{EB} = 6V, I_C = 0$	----	5.0	mA.
h_{FE}^*	DC Forward Current Transfer Ratio (Note 1)	$I_C = 0.1A, V_{CE} = 10V$ $I_C = 0.5A, V_{CE} = 10V$ $I_C = 1.0A, V_{CE} = 10V$	40 40 10	---- 200 ----	---- ---- ----
$V_{CE(sat)}^*$	Collector-Emitter Saturation Voltage	$I_C = 0.1A$ $I_B = 0.125A$	----	5	Volts
$V_{BE(sat)}^*$	Base-Emitter Saturation Voltage (Note 1)	$I_C = 1.0A, I_B = 0.10A$	----	1.4	Volts
$I_{S/b}$	Second-Breakdown Collector Current (with base forward biased)	$V_{CE} = 100V, t = 1.0\text{sec.}$	0.35	----	A
$E_{S/b}$	Second-Breakdown Energy (with base reverse biased)	$V_{EB} = 4V, R_{BE} = 20\Omega, L = 100\mu h$	50	----	μJ
h_{fe}^*	Common-Emitter Small-Signal Forward Current Transfer Ratio	$V_{CE} = 30V, I_C = 0.1A, f = 1 \text{ KHz}$ $V_{CE} = 10V, I_C = 0.2A, f = 5 \text{ KHz}$	25 3	350 ----	---- ----
$ h_{fe} ^*$	Common-Emitter Small-Signal Forward Current Transfer Ratio, $f = 5 \text{ MHz}$	$V_{CE} = 10V, I_C = 0.2A$	2.0	----	----
C_{Ob}	Collector-Base Capacitance	$V_{CB} = 10V, I_E = 0, f = 1.0\text{MHz}$	----	120	pf

Note 1: Pulse Test: Pulse width = 300 μ Sec., Rep. Rate 60Hz.

Note 2: Caution - Do not use Curve Tracer.

* Indicates JEDEC registered data.

2N3583

PACKAGE MECHANICAL DATA:

