

Product Specifications  
Small Signal Transistors

GB PNP

**Raytheon**

# Medium Current General Purpose Amplifiers and Switches

GB PNP

**Description**

General purpose medium power amplifier and switch, useful up to 500mA. The NPN complement is the CB.

**Dimensions**

Die Size: 21 x 21 mils

Bonding Pad Size:

Base — 4 mil diameter

Emitter — 4 mil diameter

**Popular Types**

2N2907A/JAN

2N2906A/JAN

2N2905A/JAN

2N2904A/JAN

Raytheon Company  
Semiconductor Division

350 Ellis Street  
Mountain View, CA 94039-7016  
(415) 968-9211  
TWX: 910-379-6484

65-1006B 4/85

## GB PNP

## Medium Current General Purpose Amplifier &amp; Switch

## Electrical Characteristics (+25°C ambient temperature unless otherwise stated)

Parameter	Conditions	2N2904A/JAN 2N2906A/JAN			2N2905A/JAN 2N2907A/JAN			Units
		Min	Typ	Max	Min	Typ	Max	
$BV_{CEO}$	$I_C = 10\text{mA}, I_B = 0$	-60	-88		-60	-82		V
$BV_{CBO}$	$I_C = 10\mu\text{A}, I_E = 0$	-60	-110		-60	-105		V
$BV_{EBO}$	$I_E = -10\mu\text{A}, I_C = 0$	-5	-7.8		-5	-7.8		V
$I_{CBO}$	$I_E = 0, V_{CB} = -50\text{V}$		0.01	50		0.01	50	nA
$I_{CBO}$	$I_E = 0, V_{CB} = -50\text{V}, T_A = 150^\circ\text{C}$		0.03	10		0.03	10	$\mu\text{A}$
$I_{EBO}$	$I_C = 0, V_{EB} = -3.5\text{V}$		0.01	50		0.01	50	nA
$H_{FE}$	$I_C = 100\mu\text{A}, V_{CE} = -10\text{V}$	40	80		75	190		
$H_{FE}$	$I_C = 1\text{mA}, V_{CE} = -10\text{V}$	40	90	75	100	210	450	
$H_{FE}$	$I_C = 1\text{mA}, V_{CE} = -10\text{V}, T_A = -55^\circ\text{C}$	20	40		50	100		
$H_{FE}$	$I_C = 10\text{mA}, V_{CE} = -10\text{V}$	40	95		100	220		
$H_{FE}$	$I_C = 150\text{mA}, V_{CE} = -10\text{V}$	40	85	120	100	195	300	
$H_{FE}$	$I_C = 500\text{mA}, V_{CE} = -10\text{V}$	40	65		50	100		
$h_{fe(ac)}$	$I_C = 1\text{mA}, V_{CE} = -10\text{V}, \text{Freq} = 1\text{kHz}$	40	100		100	230		
$h_{fe}$	$I_C = 50\text{mA}, V_{CE} = -20\text{V}, \text{Freq} = 100\text{MHz}$	2	3.2		2	3.4		
$V_{CE(SAT)}$	$I_C = 150\text{mA}, I_B = 15\text{mA}$		-0.25	-0.4		-0.2	-0.4	V
$V_{CE(SAT)}$	$I_C = 500\text{mA}, I_B = 50\text{mA}$		-0.6	-1.6		-0.54	-1.6	V
$V_{BE(SAT)}$	$I_C = 150\text{mA}, I_B = 15\text{mA}$		-0.88	-1.3		-0.88	-1.3	V
$V_{BE(SAT)}$	$I_C = 500\text{mA}, I_B = 50\text{mA}$		-1.0	-2.6		-1.0	-2.6	V
$C_{ob}$	$V_{CB} = -10\text{V}, I_E = 0$		6	8		6	8	pF
$C_{ib}$	$V_{EB} = -2\text{V}, I_C = 0$		17	30		17	30	pF
$t_{on}$	$I_C = 150\text{mA}, I_{B1} = 15\text{mA}$ (see Fig. 1)		18	45		18	45	nS
$t_{off}$	$I_C = 150\text{mA}, I_{B1} = I_{B2} = 15\text{mA}$ (see Fig. 2)		135	300		135	300	nS

The information contained in this data sheet has been carefully compiled; however, it shall not by implication or otherwise become part of the terms and conditions of any subsequent sale. Raytheon's liability shall be determined solely by its standard terms and conditions of sale. No representation as to application or use or that the circuits are either licensed or free from patent infringement is intended or implied. Raytheon reserves the right to change the circuitry and other data at any time without notice and assumes no liability for inadvertent errors.

T-37-17

Low Level, General Purpose Amplifiers & Switches GB PNP

**GB Single Transistors**

Product Type	Pkg.	Electrical Parameters @ +25°C Ambient Temperature							f <sub>t</sub> MHz Min	C <sub>ob</sub> pF Max	t <sub>ON</sub> nS Max	t <sub>OFF</sub> nS Max
		BV <sub>CBO</sub> Min @ 10μA	BV <sub>CEO</sub> Min @ 10mA	BV <sub>EBO</sub> Min @ 10μA	H <sub>FE</sub> @ I <sub>C</sub> /V <sub>CE</sub>		V <sub>CE(SAT)</sub> @ I <sub>C</sub> /I <sub>B</sub>					
					Min/ Max	mA/V	Volts Max	mA/mA				
2N721	T0-18	50	35	5	20/45	150/10	1.5	150/15	50	45		
2N722	T0-18	50	35	5	30/90	150/10	1.5	150/15	60	45		
2N722A	T0-18	50	35	5	30/90	150/10	0.5	150/15	60	40		
2N1131	T0-5	50	35	5	20/45	150/10	1.5	150/15	50	45		
2N1131J	T0-5	50	40	5	20/45	150/10	1.5	150/15	50	45		
2N1131A	T0-5	60	40	5	20/45	150/10	1.5	150/15	50	30	45	35
2N1132	T0-5	50	35	5	30/90	150/10	1.5	150/15	60	45		
2N1132J	T0-5	50	40	5	30/90	150/10	1.5	150/15	60	45		
2N1132A	T0-5	60	40	5	20/45	150/10	1.5	150/15	50	30	45	35
2N2904	T0-5	60	40	5	40/120	150/10	0.4	150/15	200	8	45	300
2N2904J,TX,V	T0-5	60	40	5	40/120	150/10	0.4	150/15	200	8	45	300
2N2904A	T0-5	60	60	5	40/120	150/10	0.4	150/15	200	8	45	300
2N2904AJ,TX,V	T0-5	60	60	5	40/120	150/10	0.4	150/15	200	8	45	300
2N2905	T0-5	60	40	5	100/300	150/10	0.4	150/15	200	8	45	300
2N2905J,TX,V	T0-5	60	40	5	100/300	150/10	0.4	150/15	200	8	45	300
2N2905A	T0-5	60	60	5	100/300	150/10	0.4	150/15	200	8	45	300
2N2905AJ,TX,V	T0-5	60	60	5	100/300	150/10	0.4	150/15	200	8	45	300
2N2906	T0-18	60	40	5	40/120	150/10	0.4	150/15	200	8	45	300
2N2906J,TX,V	T0-18	60	40	5	40/120	150/10	0.4	150/15	200	8	45	300
2N2906A	T0-18	60	60	5	40/120	150/10	0.4	150/15	200	8	45	300
2N2906AJ,TX,V	T0-18	60	60	5	40/120	150/10	0.4	150/15	200	8	45	300
2N2907	T0-18	60	40	5	100/300	150/10	0.4	150/15	200	8	45	300
2N2907J,TX,V	T0-18	60	40	5	100/300	150/10	0.4	150/15	200	8	45	300
2N2907A	T0-18	60	60	5	100/300	150/10	0.4	150/15	200	8	45	300
2N2907AJ,TX,V	T0-18	60	60	5	100/300	150/10	0.4	150/15	200	8	45	300
2N3133	T0-5	50	35	4	40/120	150/10	0.6	150/15	200	10	75	150
2N3134	T0-5	50	35	4	100/300	150/10	0.6	150/15	200	10	75	150
2N3135	T0-18	50	35	4	40/120	150/10	0.6	150/15	200	10	75	150
2N3136	T0-18	50	35	4	100/300	150/10	0.6	150/15	200	10	75	150
2N3494	T0-5	80	80	4.5	40/—	50/10	0.3	10/1	200	7	300	1000
2N3502	T0-5	45	45	5	100/300	150/10	0.4	150/15	200	8	40	100
2N3503	T0-5	60	60	5	100/300	150/10	0.4	150/15	200	8	40	100
2N3504	T0-18	45	45	5	100/300	150/10	0.4	150/15	200	8	40	100
2N3505	T0-18	60	60	5	100/300	150/10	0.4	150/15	200	8	40	100
2N4036	T0-5	90	65	7	40/140	150/10	0.65	150/15	60	30	110	700
2N4037	T0-5	60	4	7	50/250	150/10	1.4	150/15	60	30		

T-37-17

GB PNP

Medium Current General Purpose Amplifier & Switch

GB Dual Transistors

Product Type	Pkg.	Electrical Parameters @+25°C Ambient Temperature											f <sub>t</sub> MHz	C <sub>ob</sub> pF	NF dB
		BV <sub>CB0</sub> Min @ 10μA	BV <sub>CEO</sub> Min @ 10mA	BV <sub>EBO</sub> Min @ 10μA	H <sub>FE</sub> @ I <sub>C</sub> /V <sub>CE</sub>		Matching		V <sub>CE(SAT)</sub> @ I <sub>C</sub> /I <sub>B</sub>		V <sub>BE(SAT)</sub> @ I <sub>C</sub> /I <sub>B</sub>				
					Min/ Max	mA/V	H <sub>FE</sub> %	V <sub>BE</sub> mV	Volts Max	I <sub>C</sub> /I <sub>B</sub> mA/mA	Volts Max	I <sub>C</sub> /I <sub>B</sub> mA/mA			
2N2802	T0-78	25	20	5	20/200	1/5	10	5	0.5	10/1	0.9	10/1	60	8	4
2N2803	T0-78	25	20	5	20/200	1/5	20	10	0.5	10/1	0.9	10/1	60	8	4
2N2804	T0-78	25	20	5	20/200	1/5			0.5	10/1	0.9	10/1	60	8	4
2N2805	T0-78	25	20	5	40/200	1/5	10	5	0.5	10/1	0.9	10/1	60	8	4
2N2806	T0-78	25	20	5	40/200	1/5	20	10	0.5	10/1	0.9	10/1	60	8	4
2N2807	T0-78	25	20	5	40/200	1/5			0.5	10/1	0.9	10/1	60	8	4
2N3726	T0-78	50	50	5	135/420	1/10	10	5	0.25	50/2.5	1.0	50/2.5	60	8	4
2N3727	T0-78	50	50	5	135/420	1/10	10	2.5	0.25	50/2.5	1.0	50/2.5	60	8	4
2N5795	T0-78	60	60	5	40/120	150/10			0.4	150/15	1.3	150/15	200	8	
2N5796	T0-78	60	60	5	100/200	150/10			0.4	150/15	1.3	150/15	200	8	
SP2904F	T0-89	60	40	5	40/120	150/10			0.4	150/15	1.3	150/15	200	8	
SP2904AF	T0-89	60	60	5	40/120	150/10			0.4	150/15	1.3	150/15	200	8	
SP2905F	T0-89	60	40	5	100/300	150/10			0.4	150/15	1.3	150/15	200	8	
SP2905AF	T0-89	60	60	5	100/300	150/10			0.4	150/15	1.3	150/15	200	8	
SP2906F	T0-89	60	40	5	40/120	150/10			0.4	150/15	1.3	150/15	200	8	
SP2906AF	T0-89	60	60	5	40/120	150/10			0.4	150/15	1.3	150/15	200	8	
SP2907F	T0-89	60	40	5	100/300	150/10			0.4	150/15	1.3	150/15	200	8	
SP2907AF	T0-89	60	60	5	100/300	150/10			0.4	150/15	1.3	150/15	200	8	
SP3133F	T0-89	50	35	4	40/120	150/10			0.6	150/15	1.5	150/15	200	10	
SP3134F	T0-89	50	35	4	100/300	150/10			0.6	150/15	1.5	150/15	200	10	
SP3135F	T0-89	50	35	4	40/120	150/10			0.6	150/15	1.5	150/15	200	8	
SP3136F	T0-89	50	35	4	100/300	150/10			0.6	150/15	1.5	150/15	200	8	

Medium Current General Purpose Amplifier &amp; Switch GB PNP

T-37-17

## GB Quad Transistors

Product Type	Pkg.	Electrical Parameters @ +25°C Ambient Temperature							f <sub>t</sub> MHz Min	C <sub>ob</sub> pF Max
		BV <sub>CBO</sub> Min @ 10μA	BV <sub>CEO</sub> Min @ 10mA	BV <sub>EBO</sub> Min @ 10μA	H <sub>FE</sub> @ I <sub>C</sub> /V <sub>CE</sub>		V <sub>CE(SAT)</sub> @ I <sub>C</sub> /I <sub>B</sub>			
					Min/ Max	mA/V	Volts Max	mA/mA		
SP2904QD	TO-116	60	40	5	40/120	150/10	0.4	150/15	200	8
SP2904QDB	TO-116	60	40	5	40/120	150/10	0.4	150/15	200	8
SP2904QF	TO-86	60	40	5	40/120	150/10	0.4	150/15	200	8
SP2904AQD	TO-116	60	60	5	40/120	150/10	0.4	150/15	200	8
SP2904AQDB	TO-116	60	60	5	40/120	150/10	0.4	150/15	200	8
SP2904AQF	TO-86	60	60	5	40/120	150/10	0.4	150/15	200	8
SP2905QD	TO-116	60	40	5	100/300	150/10	0.4	150/15	200	8
SP2905QDB	TO-116	60	40	5	100/300	150/10	0.4	150/15	200	8
SP2905QF	TO-86	60	40	5	100/300	150/10	0.4	150/15	200	8
SP2905AQD	TO-116	60	60	5	100/300	150/10	0.4	150/15	200	8
SP2905AQDB	TO-116	60	60	5	100/300	150/10	0.4	150/15	200	8
SP2905AQF	TO-86	60	60	5	100/300	150/10	0.4	150/15	200	8
SP2906QD	TO-116	60	40	5	40/120	150/10	0.4	150/15	200	8
SP2906QDB	TO-116	60	40	5	40/120	150/10	0.4	150/15	200	8
SP2906QF	TO-86	60	40	5	40/120	150/10	0.4	150/15	200	8
SP2906AQD	TO-116	60	60	5	40/120	150/10	0.4	150/15	200	8
SP2906AQDB	TO-116	60	60	5	40/120	150/10	0.4	150/15	200	8
SP2906AQF	TO-86	60	60	5	40/120	150/10	0.4	150/15	200	8
SP2907QD	TO-116	60	40	5	100/300	150/10	0.4	150/15	200	8
SP2907QDB	TO-116	60	40	5	100/300	150/10	0.4	150/15	200	8
SP2907QF	TO-86	60	40	5	100/300	150/10	0.4	150/15	200	8
SP2907AQD	TO-116	60	60	5	100/300	150/10	0.4	150/15	200	8
SP2907AQDB	TO-116	60	60	5	100/300	150/10	0.4	150/15	200	8
SP2907AQF	TO-86	60	60	5	100/300	150/10	0.4	150/15	200	8

QD = Quad DIP (Ceramic); QDB = Quad DIP (Plastic); QF = Quad Flatpack

T-37-17

GB PNP

Medium Current General Purpose Amplifier & Switch

Typical Performance Characteristics

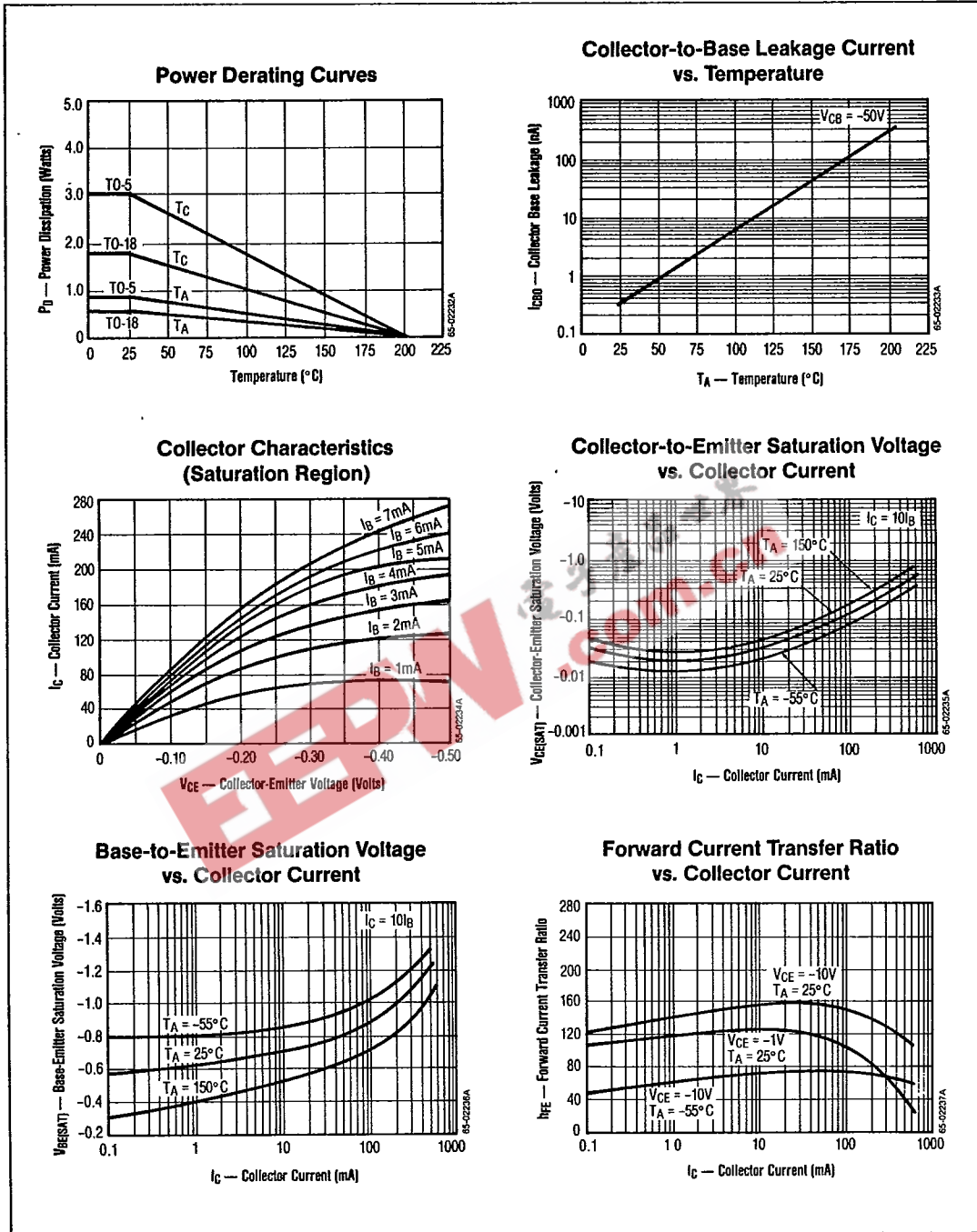

Typical Performance Characteristics (Continued)

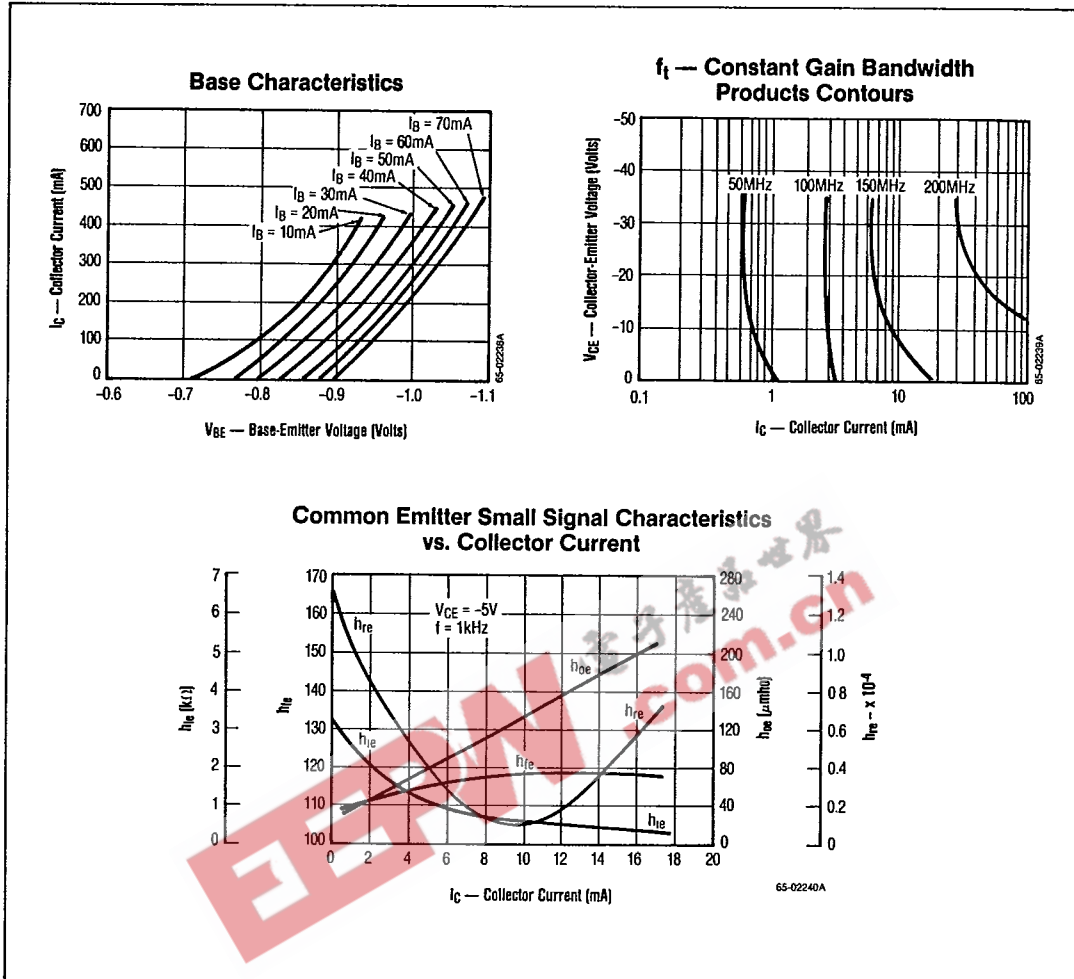

GB PNP

Medium Current General Purpose Amplifier & Switch

Typical Performance Characteristics (Continued)

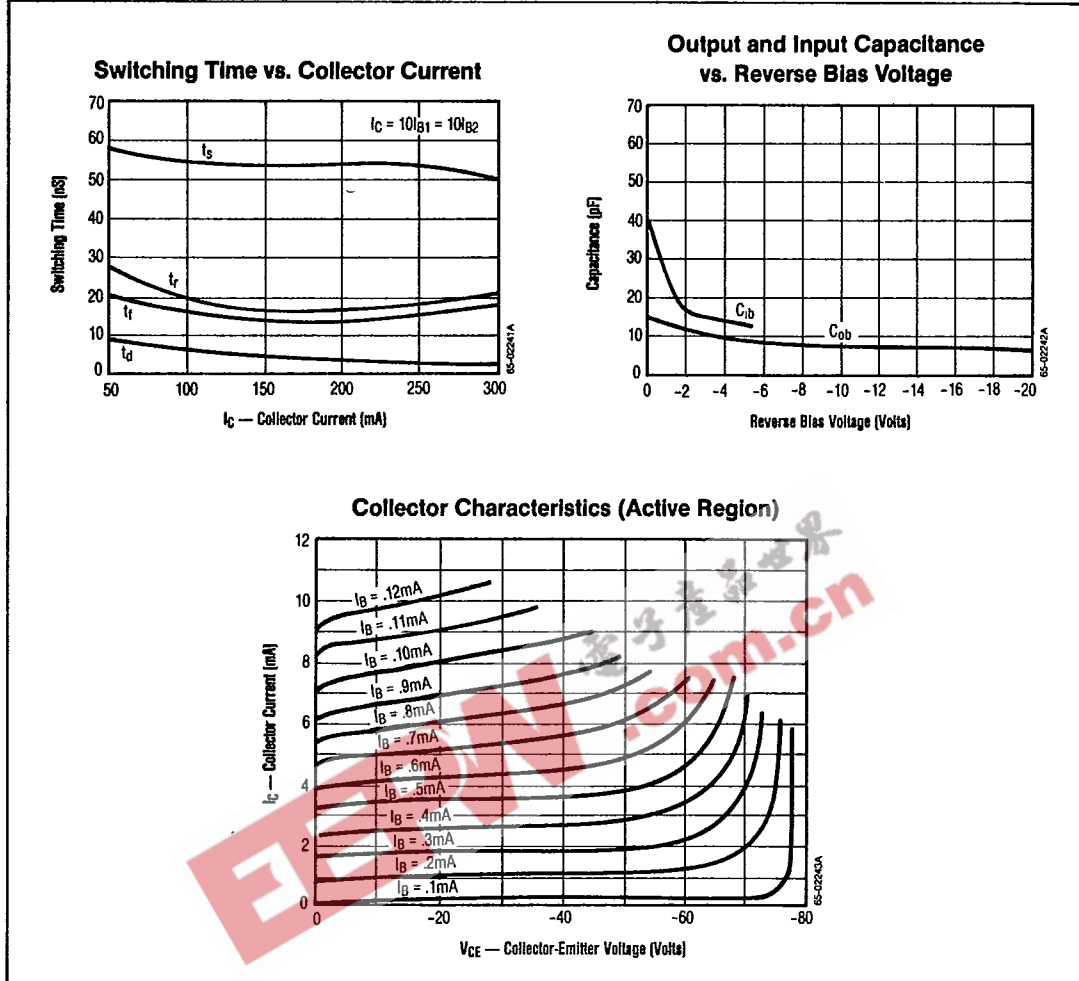



Switching Measurement Circuits

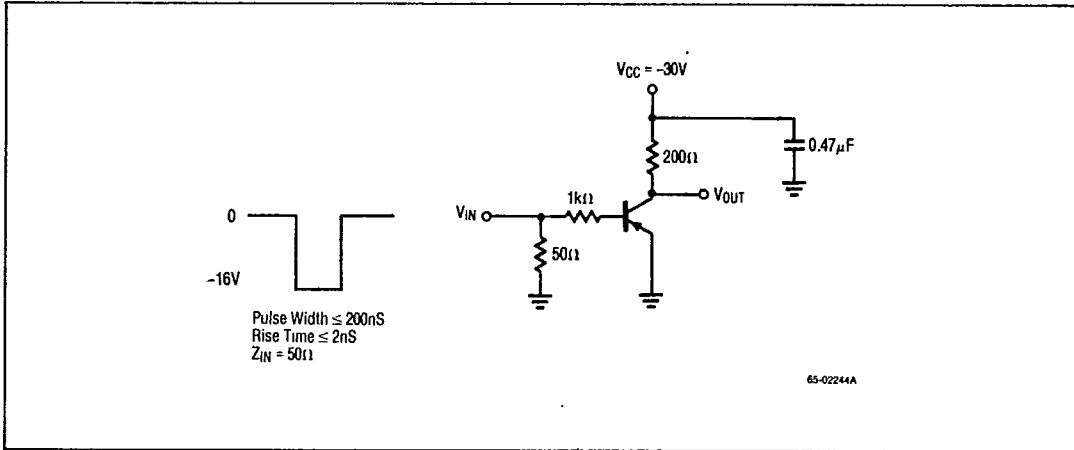

Figure 1.  $t_{ON}$  Switching

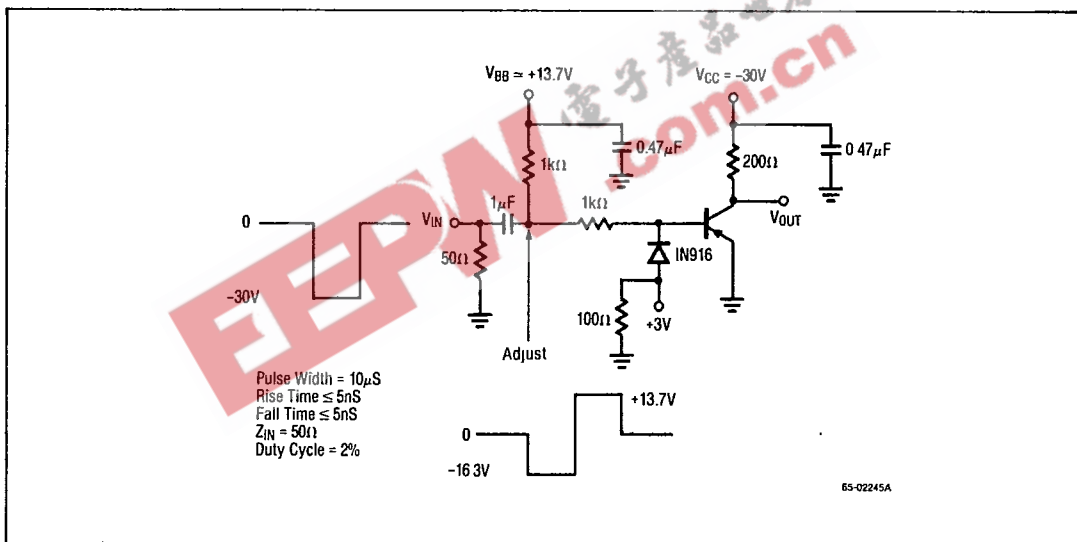

Figure 2.  $t_{OFF}$  Switching

T-37-17

GB PNP

Medium Current General Purpose Amplifier & Switch

Packaging Information

**In Accordance With JEDEC (TO-5) Outline  
(15 mil Kovar Header)**

Notes: Lead No. 3 internally connected to case.  
Can material is nickel.

Dimension	Inches		Millimeters	
	Min.	Max.	Min.	Max.
A	.240	.260	6.09	6.60
B	.016	.019	.41	.48
C	.016	.021	.41	.53
D	.335	.370	8.51	9.40
E	.305	.335	7.75	8.51
F	.100BSC		2.54BSC	
G	.200BSC		5.08BSC	
H	.009	.125	.22	3.17
J	.028	.034	.71	.86
K	.029	.045	.73	1.14
L	.500		12.70	
M	1.500		38.10	
N	45° BSC		45° BSC	

65-01179B

---

**In Accordance With JEDEC (TO-5) Outline  
(60 mil Kovar or Steel Header)**

Notes: Lead No. 3 internally connected to case.  
Can material is nickel.

Dimension	Inches		Millimeters	
	Min.	Max.	Min.	Max.
A	.240	.260	6.09	6.60
B	.016	.019	.41	.48
C	.016	.021	.41	.53
D	.335	.370	8.51	9.40
E	.305	.335	7.75	8.51
F	.100BSC		2.54BSC	
G	.200BSC		5.08BSC	
H	.009	.125	.22	3.17
J	.028	.034	.71	.86
K	.029	.045	.73	1.14
L	.500		12.70	
M	1.500		38.10	
N	45° BSC		45° BSC	

65-01180B

---

**In Accordance With JEDEC (TO-18) Outline  
(8 mil Kovar Header)**

Notes: Lead No. 3 internally connected to case.  
Can material is nickel.

Dimension	Inches		Millimeters	
	Min.	Max.	Min.	Max.
A	.170	.210	4.31	5.33
B	.016	.019	.41	.48
C	.016	.021	.41	.53
D	.209	.230	5.30	5.84
E	.178	.195	4.52	4.95
F	.050BSC		1.27BSC	
G	.100BSC		2.54BSC	
H		.030		.76
J	.036	.046	.91	1.16
K	.028	.048	.71	1.21
L	.500		12.70	
M	1.500		38.10	
N	45° BSC		45° BSC	

65-01181B

10

Raytheon

T-37-17

Medium Current General Purpose Amplifier & Switch GB PNP

Packaging Information (Continued)

**In Accordance With JEDEC (TO-78) Outline  
(15 mil Kovar Header)  
Adjacent Two Island Package**

Reference Plane  
Base and Seating Plane

Lead No. 1 internally connected to one island.  
Lead No. 7 internally connected to other island.

Note: Can material is nickel.

Dimension	Inches		Millimeters	
	Min.	Max.	Min.	Max.
A	0.165	0.185	4.19	4.70
B	0.016	0.019	0.41	0.48
C	0.016	0.021	0.41	0.53
D	0.335	0.370	8.51	9.40
E	0.305	0.335	7.75	8.51
F	0.120	0.160	3.05	4.06
G	0.200BSC		5.08BSC	
H	0.100BSC		2.54BSC	
J	0.009	0.041	0.23	1.04
K	0.028	0.034	0.71	0.86
L	0.029	0.045	0.74	1.14
M	0.500	0.750	12.70	19.05
N		0.050		1.27
P	0.250		6.35	
R	0.010	0.045	0.25	1.14
S	45°BSC		45°BSC	

65-01168B

**In Accordance With JEDEC (TO-86) Outline  
14-Lead Flatpack**

Dimension	Inches		Millimeters	
	Min.	Max.	Min.	Max.
A	0.030	0.070	0.76	1.77
B	0.010	0.019	0.25	0.48
C	0.003	0.006	0.08	0.15
D	0.240	0.275	6.10	6.98
E	0.240	0.260	6.10	6.60
F		0.290		7.37
G	0.050BSC		1.27BSC	
H	0.008	0.015	0.20	0.38
J	0.070		1.78	
K	0.005	0.035	0.13	0.89
L	0.005		0.13	
M	0.004		0.10	

65-01191B

**In Accordance With JEDEC (TO-89) Outline  
6-Lead Flatpack**

Dimension	Inches		Millimeters	
	Min.	Max.	Min.	Max.
A	0.240	0.290	6.10	7.36
B	0.115	0.160	2.92	3.81
C	0.030	0.080	0.76	2.03
D	0.003	0.006	0.08	0.15
E	0.005	0.035	0.13	0.89
F	0.010	0.019	0.25	0.48
G	0.100BSC		2.54BSC	
H	0.050BSC		1.27BSC	
J	0.070	0.250	1.78	6.35
K	0.260	0.650	6.60	16.51

65-01184B

T-37-17

GB PNP

Medium Current General Purpose Amplifier & Switch

Packaging Information (Continued)

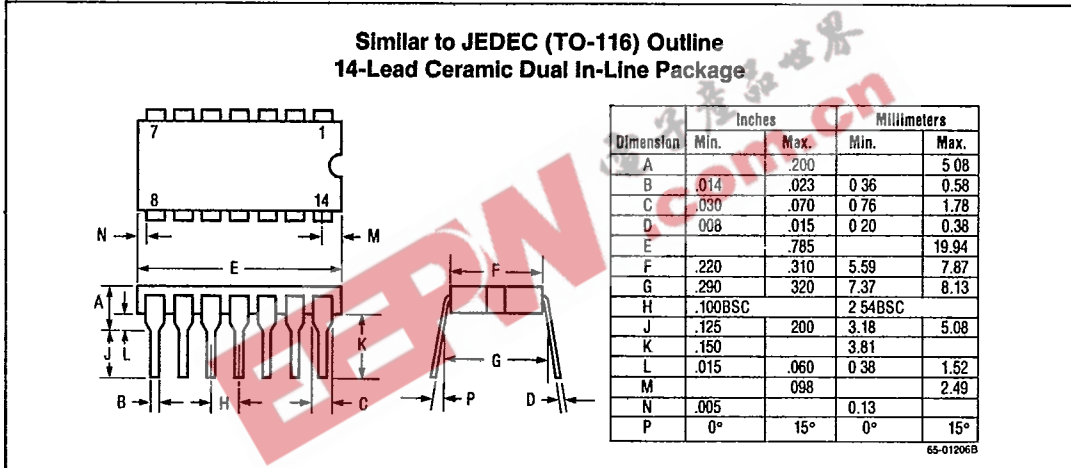
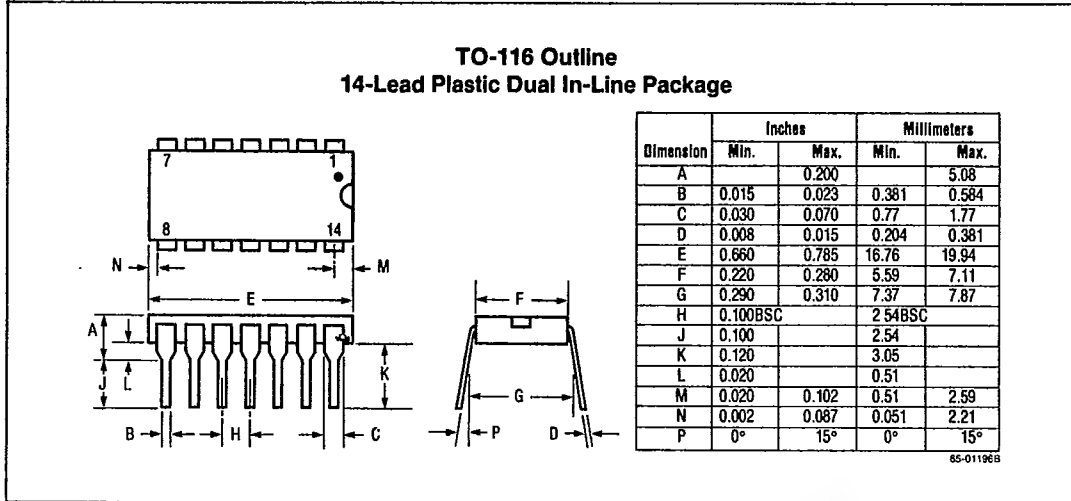

Raytheon Company  
Semiconductor Division

350 Ellis Street  
Mountain View, CA 94039-7016  
(415) 968-9211  
TWX: 910-379-6484

**Raytheon**