



2SA2016

PNP PLANAR TRANSISTOR

PNP EPITAXIAL PLANAR TRANSISTOR

■ APPLICATIONS

* Relay drivers, lamp drivers, motor drivers, strobes.

■ FEATURES

- *High current capacitance.
- *Low collector-to-emitter saturation voltage.
- *High-speed switching
- *High allowable power dissipation.

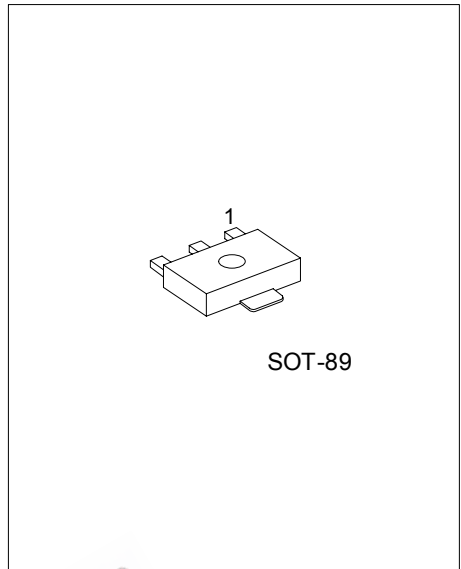

*Pb-free plating product number: 2SA2016L

■ ORDERING INFORMATION

Order Number		Package	Pin Assignment			Packing
Normal	Lead Free Plating		1	2	3	
2SA2016-AB3-R	2SA2016L-AB3-R	SOT-89	B	C	E	Tape Reel

<p>2SA2016L-AB3-R</p> <p>(1) Packing Type</p> <p>(2) Package Type</p> <p>(3) Lead Plating</p>	<p>(1) R: Tape Reel</p> <p>(2) AB3: SOT-89</p> <p>(3) L: Lead Free Plating Blank: Pb/Sn</p>
---	---

■ ABSOLUTE MAXIMUM RATINGS (Ta=25°C)

PARAMETER	SYMBOL	RATINGS	UNIT
Collector-Base Voltage	V_{CBO}	-50	V
Collector-Emitter Voltage	V_{CEO}	-50	V
Emitter-Base Voltage	V_{EBO}	-6	V
Collector Dissipation Mounted on a ceramic board (250mm ² *0.8mm)	P_c	1.3	W
Collector Dissipation (Tc=25°C)	P_c	3.5	W
Collector Current	I_c	-7	A
Collector Current	I_{cp}	-10	A
Base Current	I_B	-1.2	A
Junction Temperature	T_J	150	°C
Storage Temperature	T_{STG}	-55 to +150	°C

Note Absolute maximum ratings are those values beyond which the device could be permanently damaged. Absolute maximum ratings are stress ratings only and functional device operation is not implied.

■ ELECTRICAL CHARACTERISTICS (Tc=25 °C)

PARAMETER	SYMBOL	TEST CONDITIONS	MIN	TYP	MAX	UNIT
Collector-to-Base Breakdown Voltage	BV_{CBO}	$I_c = -10\mu A, I_E = 0$	-50			V
Collector-to- Emitter Breakdown Voltage	BV_{CEO}	$I_c = -1mA, R_{BE} = \infty$	-50			V
Emitter-to-Base Breakdown Voltage	BV_{EBO}	$I_c = 0, I_E = -10\mu A$	-6			V
Collector Cut-Off Current	I_{CBO}	$V_{CB} = -40V, I_E = 0$			-0.1	μA
Emitter Cut-Off Current	I_{EBO}	$V_{EB} = -4V, I_C = 0$			-0.1	μA
DC Current Gain	h_{FE}	$V_{CE} = -2V, I_c = -500mA$	200		560	
Collector-Emitter Saturation Voltage	$V_{CE(SAT)}$	$I_c = -3.5A, I_B = -175mA$		-0.23	-0.39	V
		$I_c = -2A, I_B = -40mA$		-0.24	-0.40	V
Base-Emitter Saturation Voltage	$V_{BE(SAT)}$	$I_c = -2A, I_B = -40mA$		-0.83	-1.2	V
Gain Bandwidth Product	f_T	$V_{CE} = -10V, I_c = -500mA$		290		MHz
Output Capacitance	C_{ob}	$V_{CB} = -10V, f = 1MHz$		50		pF
Turn-on Time	t_{ON}	See specified Test Circuit		40		ns
Storage Time	t_{STG}	See specified Test Circuit		225		ns
Fall Time	t_F	See specified Test Circuit		25		ns

■ SWITCHING TIME TEST CIRCUIT

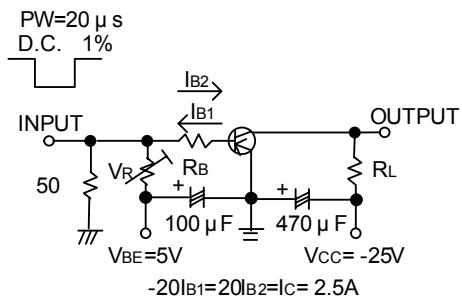

EEPW 电子產品世界 .com.cn

TYPICAL CHARACTERISTICS

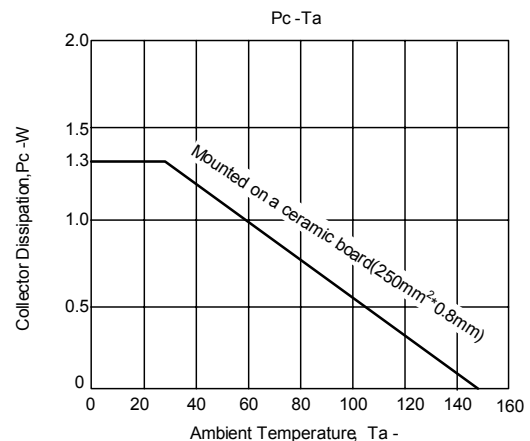
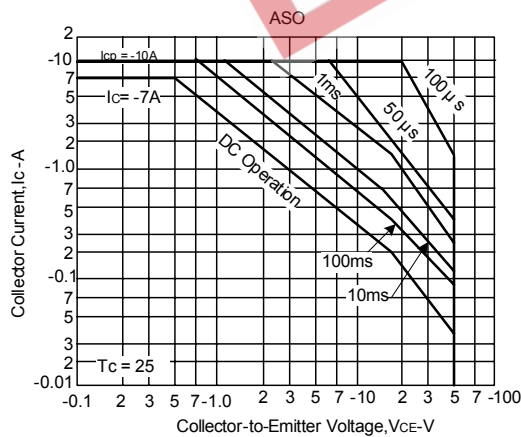
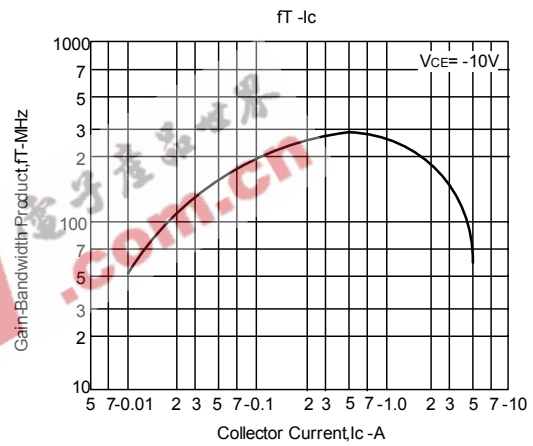
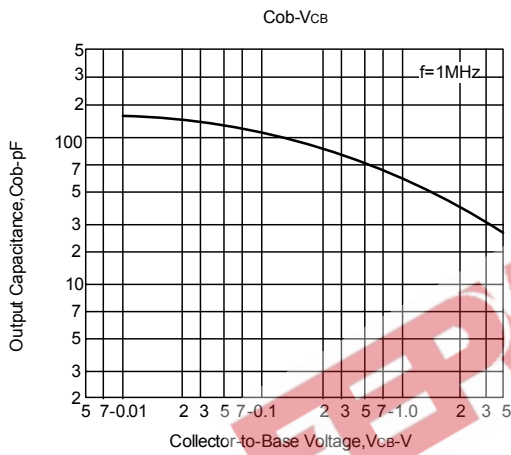
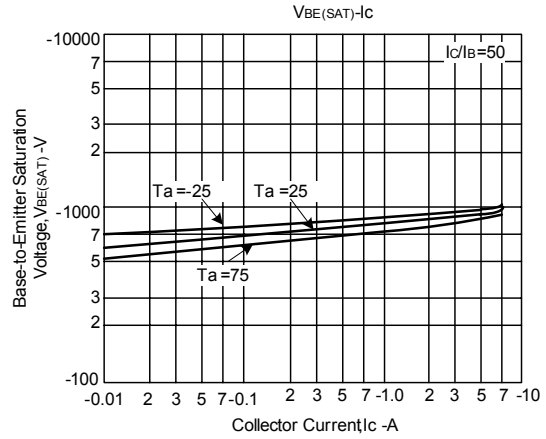
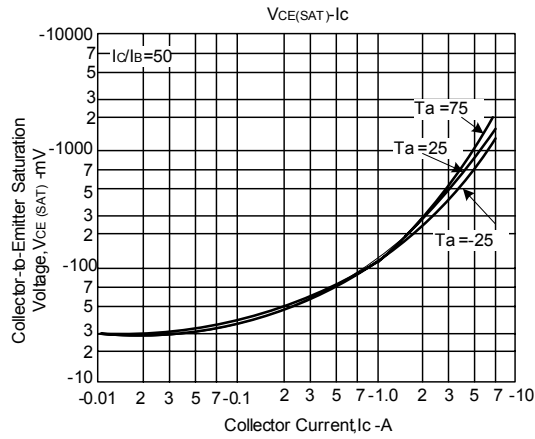

■ TYPICAL CHARACTERISTICS(Cont.)

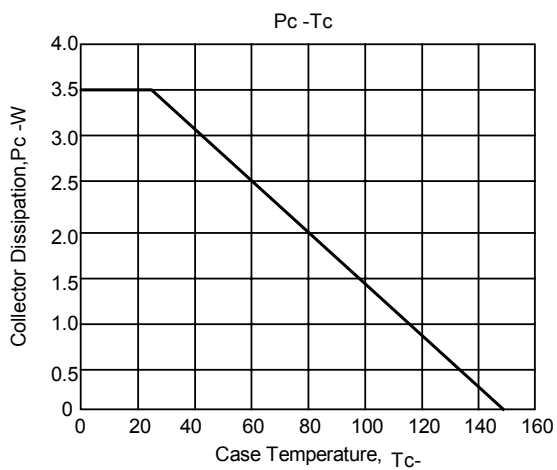
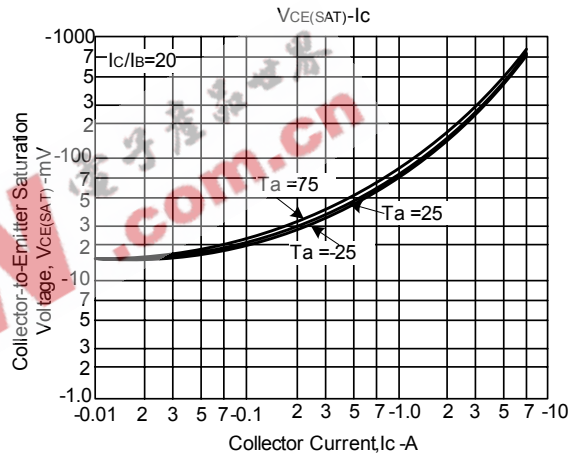
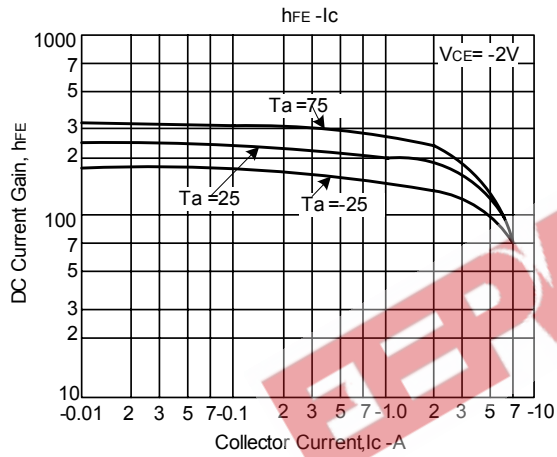
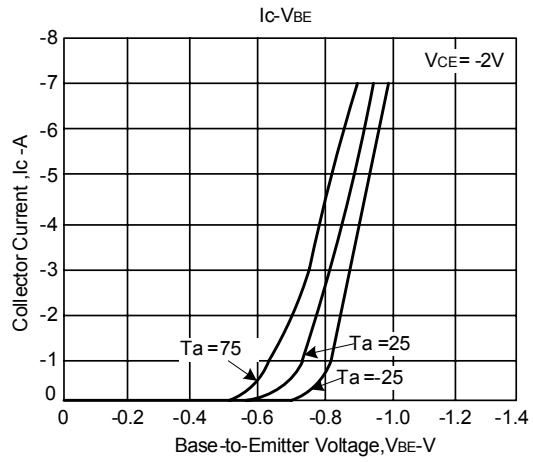
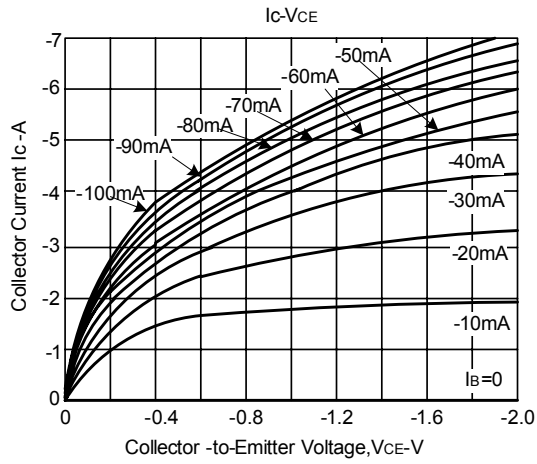

EEPW 電子產品世界
.com.cn

UTC assumes no responsibility for equipment failures that result from using products at values that exceed, even momentarily, rated values (such as maximum ratings, operating condition ranges, or other parameters) listed in products specifications of any and all UTC products described or contained herein. UTC products are not designed for use in life support appliances, devices or systems where malfunction of these products can be reasonably expected to result in personal injury. Reproduction in whole or in part is prohibited without the prior written consent of the copyright owner. The information presented in this document does not form part of any quotation or contract, is believed to be accurate and reliable and may be changed without notice.