

Low $V_{CE(sat)}$ Transistor (–20V, –3A)

2SB1424 / 2SA1585S

●Features

- 1) Low $V_{CE(sat)}$.
 $V_{CE(sat)} = -0.2V$ (Typ.)
 $(I_C/I_B = -2A / -0.1A)$
- 2) Excellent DC current gain characteristics.
- 3) Complements the 2SD2150 / 2SC4115S.

●Structure

Epitaxial planar type
 PNP silicon transistor

●External dimensions (Units: mm)

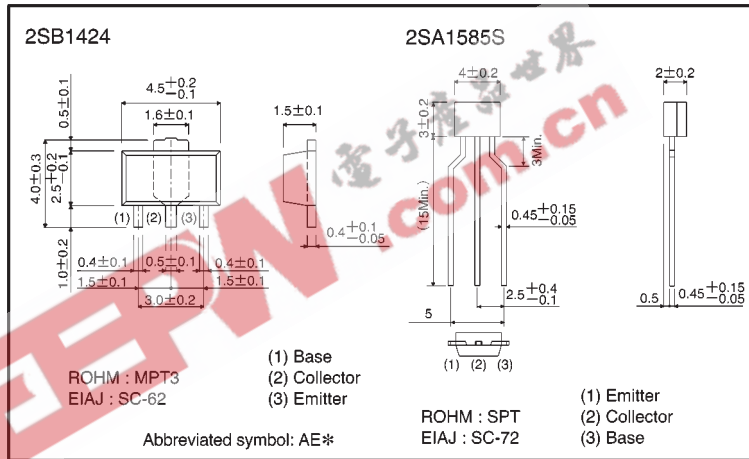

* Denotes h_{FE}

●Absolute maximum ratings ($T_a = 25^\circ C$)

Parameter	Symbol	Limits	Unit
Collector-base voltage	V_{CBO}	–20	V
Collector-emitter voltage	V_{CEO}	–20	V
Emitter-base voltage	V_{EBO}	–6	V
Collector current	2SB1424	–3	A
	2SA1585S	–2	
	I_{CP}	–5	A (Pulse) *
Collector power dissipation	2SB1424	0.6	W
	2SA1585S	0.4	
Junction temperature	T_J	150	$^\circ C$
Storage temperature	T_{stg}	–55~+150	$^\circ C$

* Single pulse $P_w=10ms$

●Electrical characteristics (Ta = 25°C)

Parameter	Symbol	Min.	Typ.	Max.	Unit	Conditions
Collector-base breakdown voltage	BV_{CBO}	-20	—	—	V	$I_c = -50 \mu A$
Collector-emitter breakdown voltage	BV_{CEO}	-20	—	—	V	$I_c = -1 mA$
Emitter-base breakdown voltage	BV_{EBO}	-6	—	—	V	$I_E = -50 \mu A$
Collector cutoff current	I_{CBO}	—	—	-0.1	μA	$V_{CB} = -20V$
Emitter cutoff current	I_{EBO}	—	—	-0.1	μA	$V_{EB} = -5V$
Collector-emitter saturation voltage	$V_{CE(sat)}$	—	—	-0.5	V	$I_c/I_b = -2A/-0.1A$
DC current transfer ratio	h_{FE}	120	—	390	—	$V_{CE} = -2V, I_c = -0.1A$
Transition frequency	f_T	—	240	—	MHz	$V_{CE} = -2V, I_E = 0.5A, f = 100MHz$
Output capacitance	C_{ob}	—	35	—	pF	$V_{CB} = -10V, I_E = 0A, f = 1MHz$

●Packaging specifications and f_{FE}

h_{FE} values are classified as follows :

Type	h_{FE}	Package Code Basic ordering unit (pieces)	Taping		Item	Q	R
			TP	T100	h_{FE}	120~270	180~390
2SA1585S	QR	○	5000	1000	—	—	—
2SB1424	QR	—	—	○	—	—	—

●Electrical characteristic curves

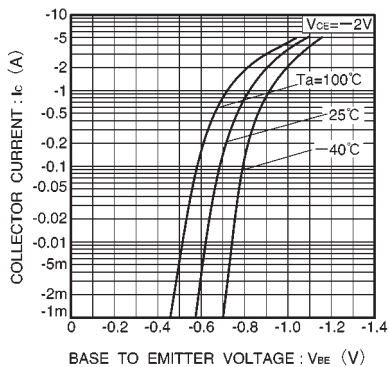

Fig.1 Grounded emitter propagation characteristics

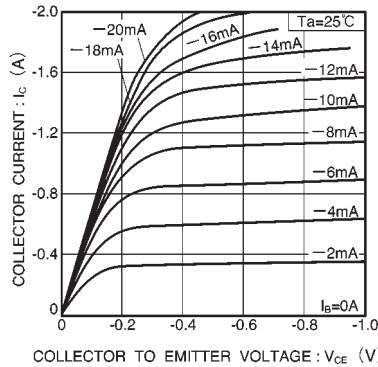

Fig.2 Grounded emitter output characteristics (I)

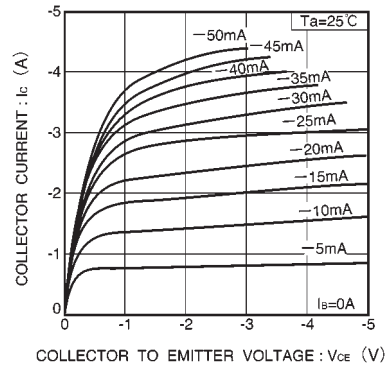

Fig.3 Grounded emitter output characteristics (II)

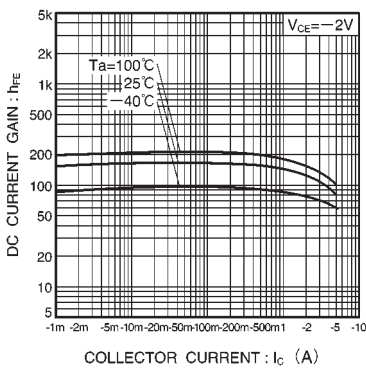

Fig.4 DC current gain vs. collector current

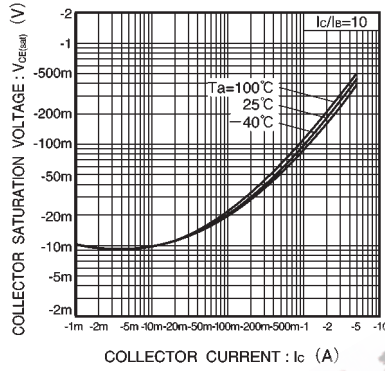

Fig.5 Collector-emitter saturation voltage vs. collector current (I)

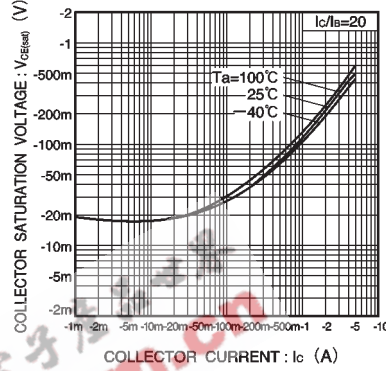

Fig.6 Collector-emitter saturation voltage vs. collector current (II)

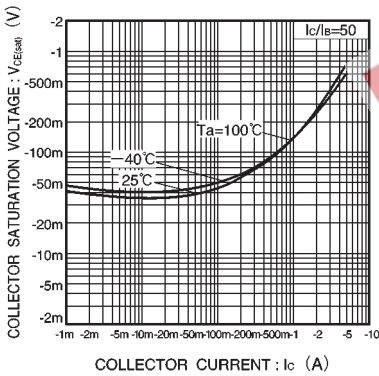

Fig.7 Collector-emitter saturation voltage vs. collector current (III)

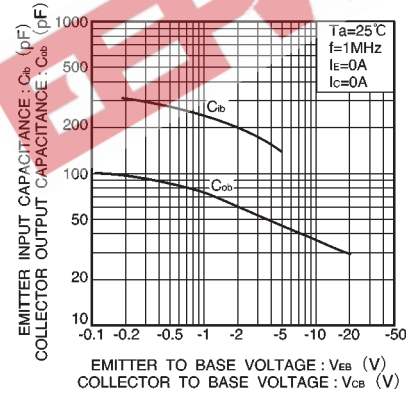

Fig.8 Gain bandwidth product vs. emitter current
Collector output capacitance vs. collector-base voltage

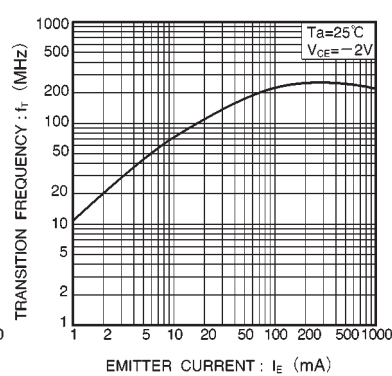

Fig.9 Emitter input capacitance vs. emitter base voltage