

2SA1806

Silicon PNP epitaxial planer type

For high speed switching

■ Features

- High-speed switching.
- Low collector to emitter saturation voltage $V_{CE(sat)}$.
- SS-Mini type package, allowing downsizing of the equipment and automatic insertion through the tape packing and the magazine packing.

■ Absolute Maximum Ratings (Ta=25°C)

Parameter	Symbol	Ratings	Unit
Collector to base voltage	V_{CBO}	-15	V
Collector to emitter voltage	V_{CEO}	-15	V
Emitter to base voltage	V_{EBO}	-4	V
Peak collector current	I_{CP}	-100	mA
Collector current	I_C	-50	mA
Collector power dissipation	P_C	125	mW
Junction temperature	T_j	125	°C
Storage temperature	T_{stg}	-55 ~ +125	°C

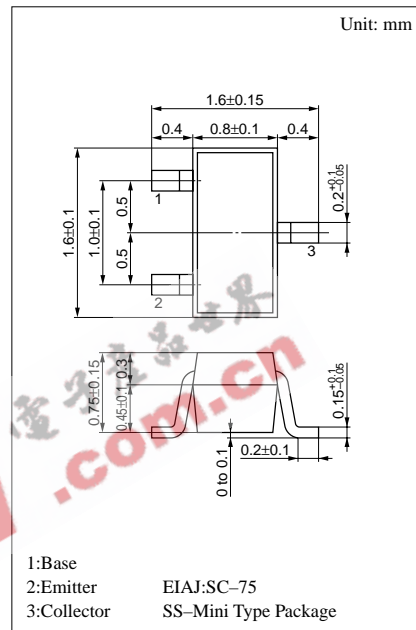

Marking symbol : AK

■ Electrical Characteristics (Ta=25°C)

Parameter	Symbol	Conditions	min	typ	max	Unit
Collector cutoff current	I_{CBO}	$V_{CB} = -8V, I_E = 0$			-0.1	μA
Emitter cutoff current	I_{EBO}	$V_{EB} = -3V, I_C = 0$			-0.1	μA
Forward current transfer ratio	h_{FE1}^*	$V_{CE} = -1V, I_C = -10mA$	50		150	
	h_{FE2}	$V_{CE} = -1V, I_C = -1mA$	30			
Collector to emitter saturation voltage	$V_{CE(sat)}$	$I_C = -10mA, I_B = -1mA$		-0.1	-0.2	V
Transition frequency	f_T	$V_{CB} = -10V, I_E = 10mA, f = 200MHz$	800	1500		MHz
Collector output capacitance	C_{ob}	$V_{CB} = -5V, I_E = 0, f = 1MHz$		1		pF
Turn-on time	t_{on}	(Note 1) Next page		12		ns
Turn-off time	t_{off}	(Note 1) Next page		20		ns
Storage time	t_{stg}	(Note 1) Next page		19		ns

* h_{FE1} Rank classification

Rank	Q	R
h_{FE1}	50 ~ 120	90 ~ 150
Marking Symbol	AKQ	AKR

