

# 2SC1509

Silicon NPN epitaxial planer type

For low-frequency driver amplification  
Complementary to 2SA777

■ Features

- High collector to emitter voltage  $V_{CEO}$ .
- Optimum for the driver stage of a low-frequency and 25 to 30W output amplifier.

■ Absolute Maximum Ratings ( $T_a=25^\circ\text{C}$ )

Parameter	Symbol	Ratings	Unit
Collector to base voltage	$V_{CBO}$	80	V
Collector to emitter voltage	$V_{CEO}$	80	V
Emitter to base voltage	$V_{EBO}$	5	V
Peak collector current	$I_{CP}$	1	A
Collector current	$I_C$	0.5	A
Collector power dissipation	$P_C$	1	W
Junction temperature	$T_j$	150	$^\circ\text{C}$
Storage temperature	$T_{stg}$	-55 ~ +150	$^\circ\text{C}$

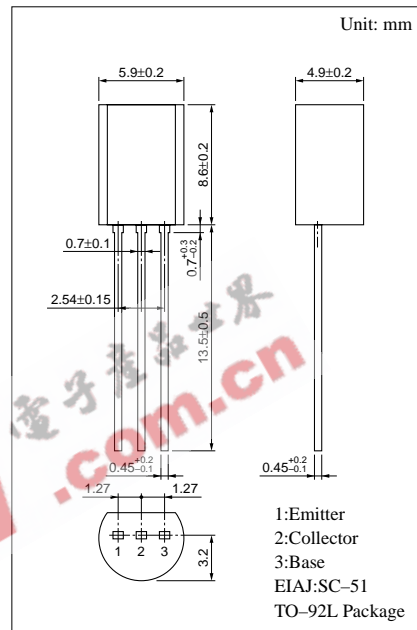

■ Electrical Characteristics ( $T_a=25^\circ\text{C}$ )

Parameter	Symbol	Conditions	min	typ	max	Unit
Collector cutoff current	$I_{CBO}$	$V_{CB} = 20\text{V}, I_E = 0$			0.1	$\mu\text{A}$
Collector to base voltage	$V_{CBO}$	$I_C = 10\mu\text{A}, I_E = 0$	80			V
Collector to emitter voltage	$V_{CEO}$	$I_C = 100\mu\text{A}, I_B = 0$	80			V
Emitter to base voltage	$V_{EBO}$	$I_E = 10\mu\text{A}, I_C = 0$	5			V
Forward current transfer ratio	$h_{FE1}^{*1}$	$V_{CE} = 10\text{V}, I_C = 150\text{mA}^{*2}$	130		330	
	$h_{FE2}$	$V_{CE} = 5\text{V}, I_C = 500\text{mA}^{*2}$	50	100		
Collector to emitter saturation voltage	$V_{CE(sat)}$	$I_C = 300\text{mA}, I_B = 30\text{mA}^{*2}$		0.2	0.4	V
Base to emitter saturation voltage	$V_{BE(sat)}$	$I_C = 300\text{mA}, I_B = 30\text{mA}^{*2}$		0.85	1.2	V
Transition frequency	$f_T$	$V_{CB} = 10\text{V}, I_E = -50\text{mA}, f = 100\text{MHz}$		120		MHz
Collector output capacitance	$C_{ob}$	$V_{CB} = 10\text{V}, I_E = 0, f = 1\text{MHz}$		11	20	pF

\*2 Pulse measurement

\*1  $h_{FE1}$  Rank classification

Rank	R	S
$h_{FE1}$	130 ~ 220	185 ~ 330

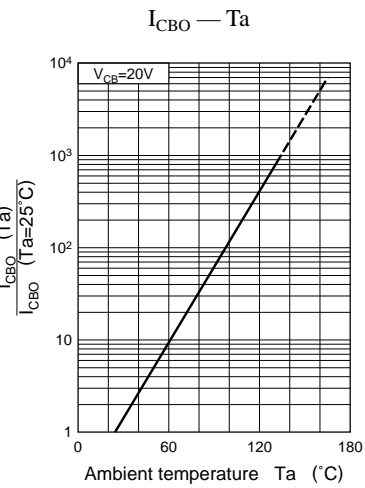
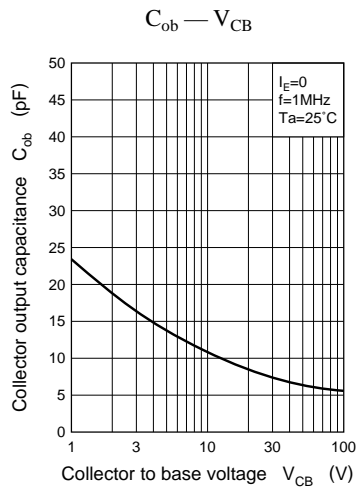
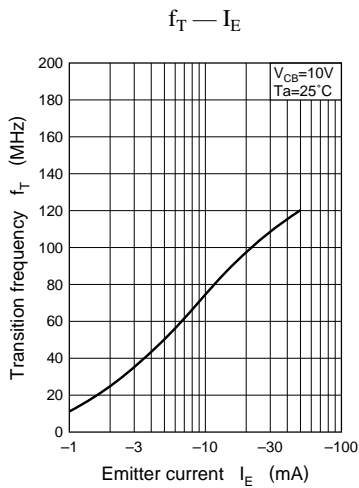
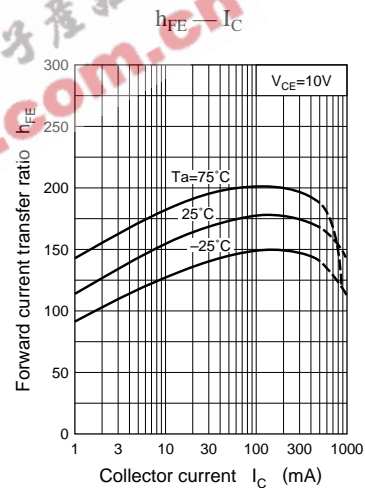
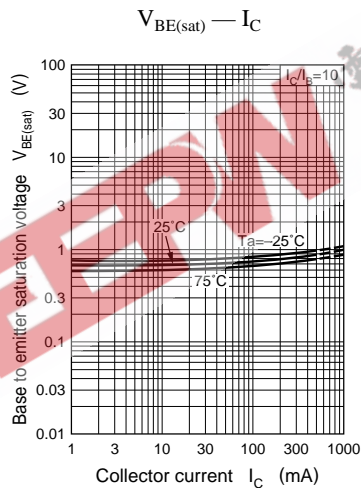
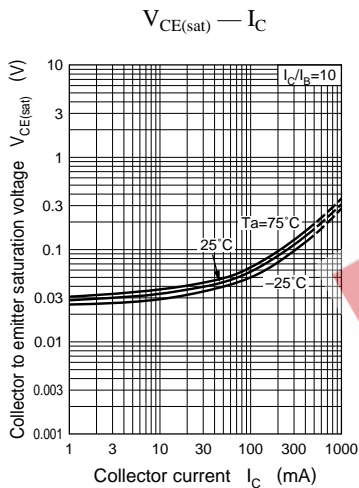
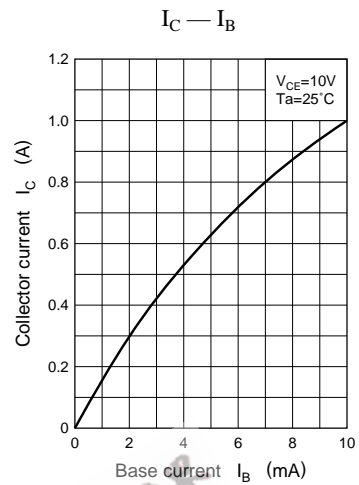
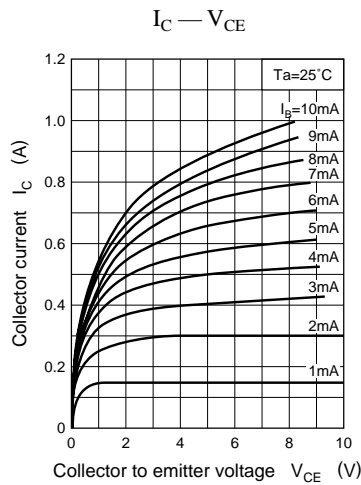
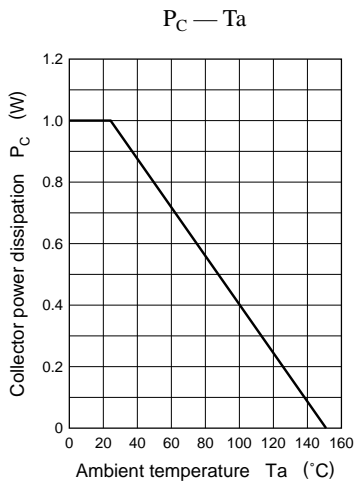

$I_{CEO} - T_a$

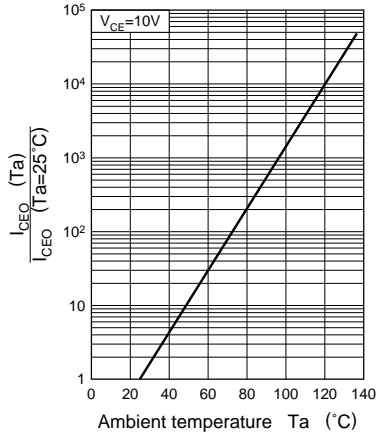

Area of safe operation (ASO)

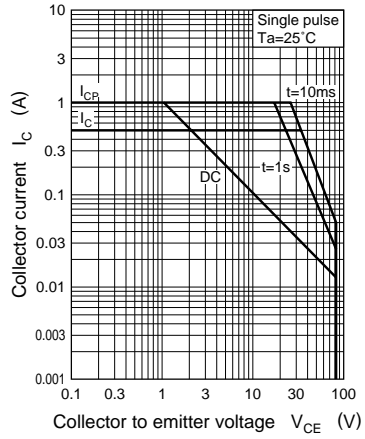

EEPW 电子产品世界 .com.cn