

SANYO	No.3136	2SA1732
		PNP Epitaxial Planar Silicon Transistor

High-Speed Switching Applications

Features

- Adoption of FBET, MBIT processes
- Large current capacity
- Low collector-to-emitter saturation voltage
- Fast switching speed

Absolute Maximum Ratings at Ta = 25°C

			unit
Collector to Base Voltage	V _{CB0}	-50	V
Collector to Emitter Voltage	V _{CE0}	-40	V
Emitter to Base Voltage	V _{EBO}	-5	V
Collector Current	I _C	-8	A
Collector Current(Pulse)	I _{CP}	-12	A
Collector Dissipation	P _C	1	W
		15	W
Junction Temperature	T _j	150	°C
Storage Temperature	T _{stg}	-55 to +150	°C

Electrical Characteristics at Ta = 25°C

			min	typ	max	unit
Collector Cutoff Current	I _{CBO}	V _{CB} = -40V, I _E = 0			-1	μA
Emitter Cutoff Current	I _{EBO}	V _{EB} = -3V, I _C = 0			-1	μA
DC Current Gain	h _{FE(1)}	V _{CE} = -2V, I _C = -500mA	70*		280*	
	h _{FE(2)}	V _{CE} = -2V, I _C = -8A	25			
Gain-Bandwidth Product	f _T	V _{CE} = -2V, I _C = -500mA		250		MHz
Output Capacitance	c _{ob}	V _{CB} = -10V, f = 1MHz		100		pF
C-E Saturation Voltage	V _{CE(sat)}	I _C = -4A, I _B = -200mA	-0.3	-0.8		V
B-E Saturation Voltage	V _{BE(sat)}	I _C = -4A, I _B = -200mA	-0.95	-1.3		V
C-B Breakdown Voltage	V _{(BR)CBO}	I _C = -100μA, I _E = 0	-50			V
C-E Breakdown Voltage	V _{(BR)CEO}	I _C = -1mA, R _{BE} = ∞	-40			V
E-B Breakdown Voltage	V _{(BR)EBO}	I _E = -100μA, I _C = 0	-5			V
Turn-ON Time	t _{on}	See specified Test Circuit.		50	100	ns
Storage Time	t _{stg}	∕		120	220	ns
Turn-OFF Time	t _{off}	∕		150	300	ns

*: The 2SA1732 is classified by 500mA h_{FE} as follows:

70 Q 140	100 R 200	140 S 280
----------	-----------	-----------

Switching Time Test Circuit

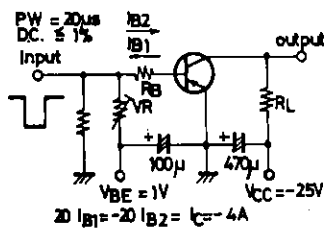

Unit (Capacitance : F)

Package Dimensions 2045B

(unit : mm)

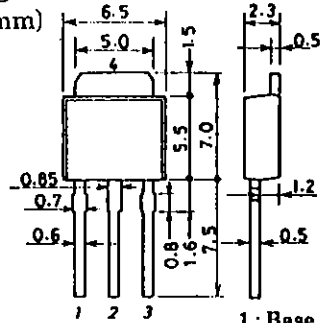

- 1: Base
- 2: Collector
- 3: Emitter
- 4: Collector

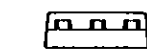

2.3 → ← 2.3

SANYO: TP

Package Dimensions 2044B

(unit : mm)

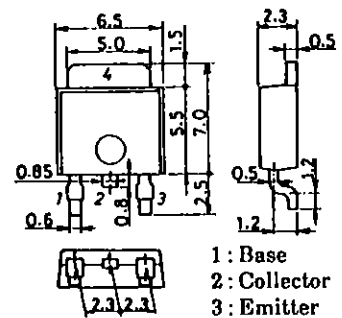

- 1: Base
- 2: Collector
- 3: Emitter
- 4: Collector

SANYO: TP-FA

SANYO Electric Co., Ltd. Semiconductor Business Headquarters

TOKYO OFFICE Tokyo Bldg., 1-10, 1 Chome, Ueno, Taito-ku, TOKYO, 110 JAPAN

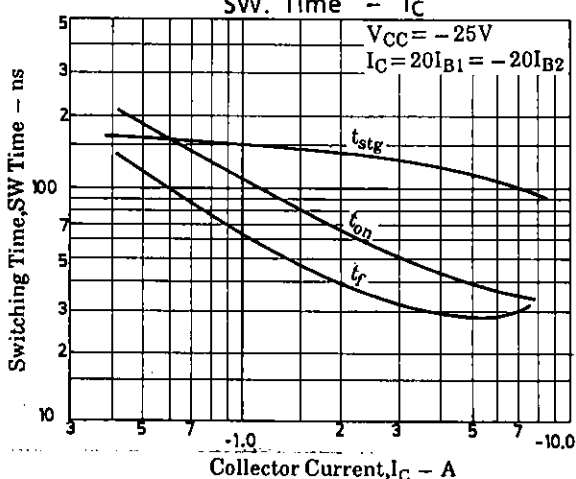
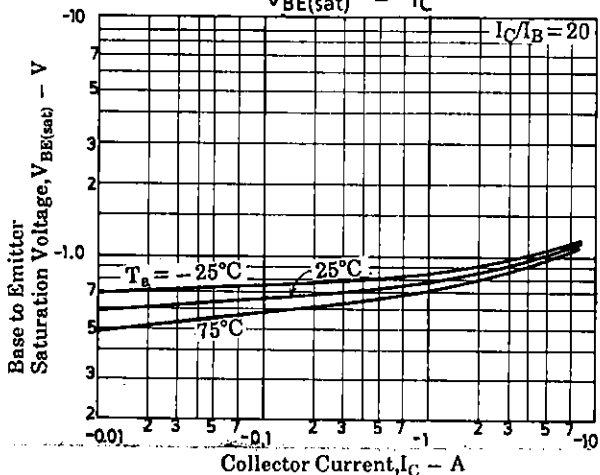
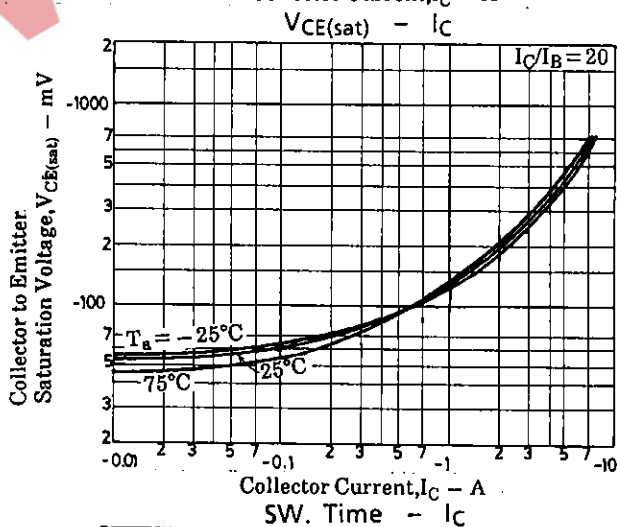
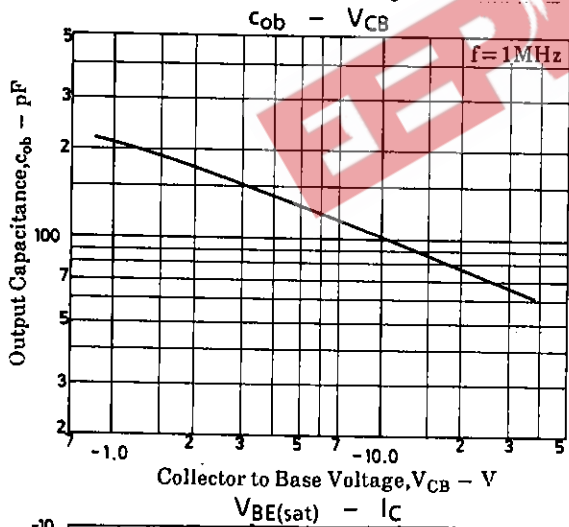
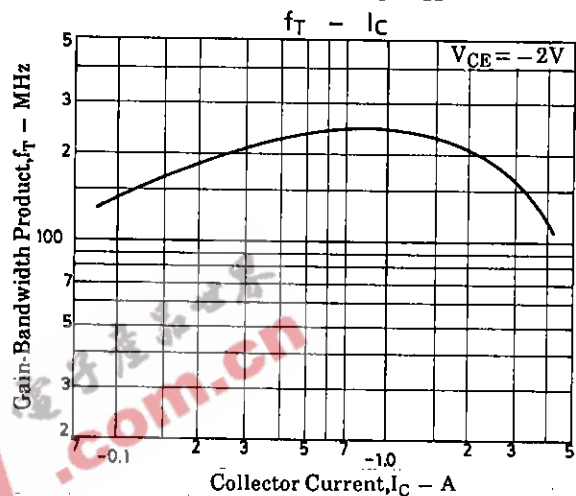
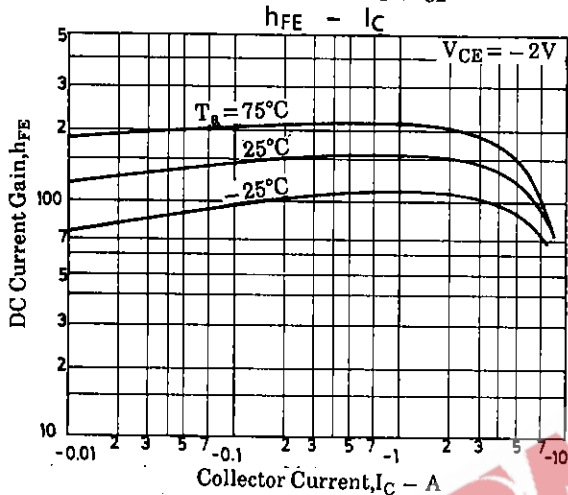
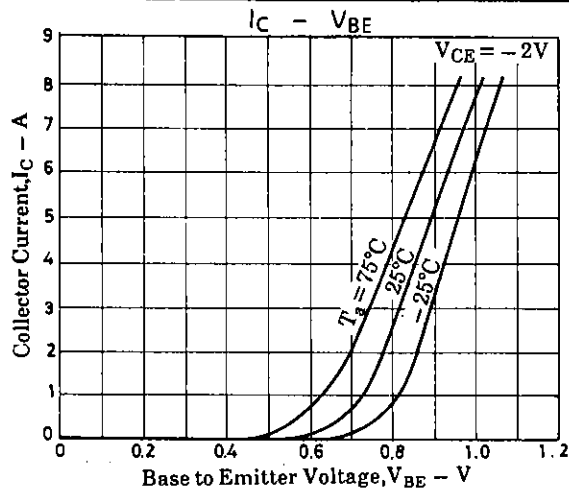
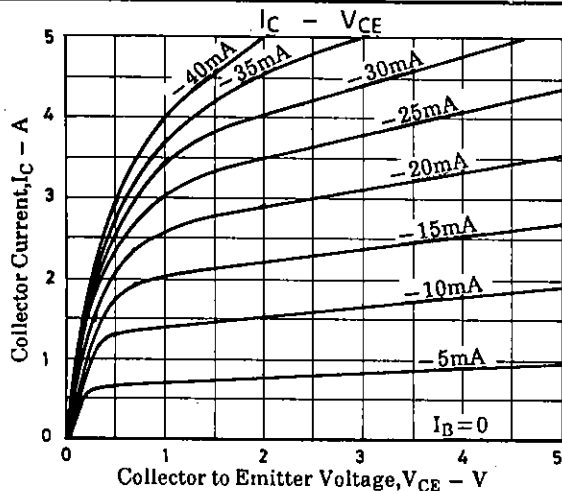

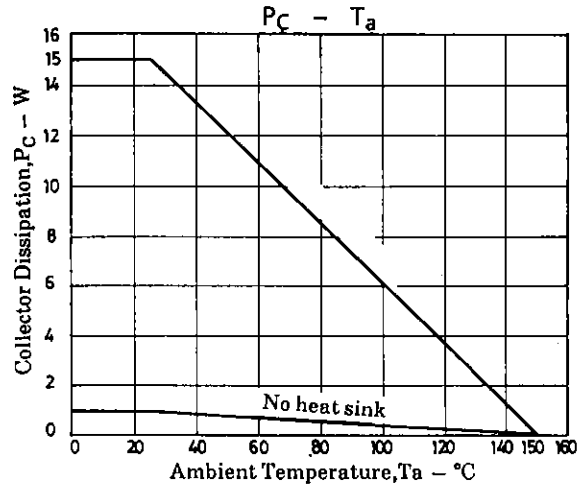
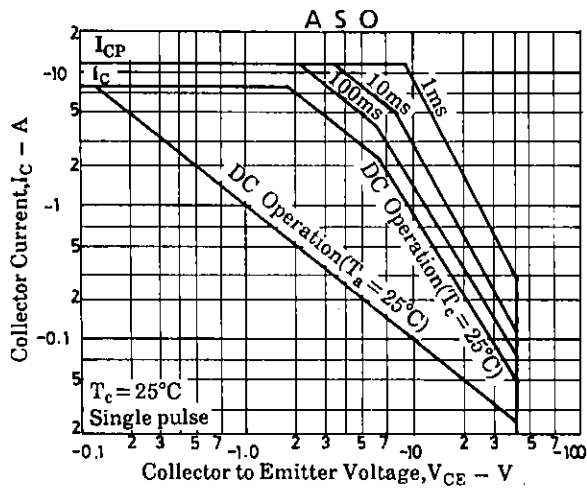

EEPW.com.cn 电子产品世界

■ No products described or contained herein are intended for use in surgical implants, life-support systems, aerospace equipment, nuclear power control systems, vehicles, disaster/crime-prevention equipment and the like, the failure of which may directly or indirectly cause injury, death or property loss.

■ Anyone purchasing any products described or contained herein for an above-mentioned use shall:

- ① Accept full responsibility and indemnify and defend SANYO ELECTRIC CO., LTD., its affiliates, subsidiaries and distributors and all their officers and employees, jointly and severally, against any and all claims and litigation and all damages, cost and expenses associated with such use:
- ② Not impose any responsibility for any fault or negligence which may be cited in any such claim or litigation on SANYO ELECTRIC CO., LTD., its affiliates, subsidiaries and distributors or any of their officers and employees jointly or severally.

■ Information (including circuit diagrams and circuit parameters) herein is for example only; it is not guaranteed for volume production. SANYO believes information herein is accurate and reliable, but no guarantees are made or implied regarding its use or any infringements of intellectual property rights or other rights of third parties.