

## SILICON PNP EPITAXIAL TRANSISTOR

### DESCRIPTION

The UTC 2SA1201 is designed for power amplifier and voltage amplifier applications.

### FEATURES

- \*High voltage:  $V_{CEO} = -120V$
- \*High transition frequency:  $f_T = 120MHz$ (typ.)
- \* $P_c = 1$  to 2 W(mounted on ceramic substrate)

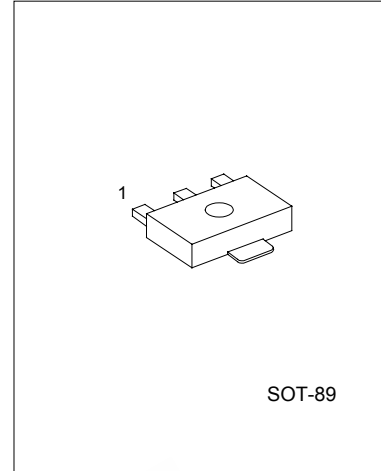

1:EMITTER 2:COLLECTOR 3:BASE

### ABSOLUTE MAXIMUM RATINGS (Ta=25°C)

PARAMETER	SYMBOL	VALUE	UNIT
Collector-Base Voltage	$V_{CBO}$	-120	V
Collector-Emitter Voltage	$V_{CEO}$	-120	V
Emitter-Base Voltage	$V_{EBO}$	-5	V
Collector Current	$I_C$	-800	mA
Base Current	$I_B$	-160	mA
Collector Power Dissipation	$P_C$	500	mW
	$P_C^*$	1000	mW
Junction Temperature	$T_J$	150	°C
Storage Temperature	TSTG	-55 ~ +150	°C

\* : Mounted on ceramic substrate( 250mm<sup>2</sup> × 0.8t )

### ELECTRICAL CHARACTERISTICS (Ta=25°C, unless otherwise specified)

PARAMETER	SYMBOL	TEST CONDITIONS	MIN	TYP	MAX	UNIT
Collector to emitter breakdown voltage	$V_{(BR)CEO}$	$I_C = -10mA, I_B = 0$	-120			V
Emitter to Base breakdown voltage	$V_{(BR)EBO}$	$I_E = -1mA, I_C = 0$	-5			V
Collector cut-off current	$I_{CBO}$	$V_{CB} = -120V, I_E = 0$			-0.1	μA
Emitter cut-off current	$I_{EBO}$	$V_{EB} = -5V, I_C = 0$			-0.1	μA
DC Current Gain	$h_{FE}$	$V_{CE} = -5V, I_C = -100mA$	80		240	
Collector to emitter saturation voltage	$V_{CE(sat)}$	$I_C = -500mA, I_B = -50mA$			-1.0	V
Base to emitter voltage	$V_{BE}$	$V_{CE} = -5V, I_C = -100mA$			-1.0	V
Transition frequency	$f_T$	$V_{CE} = -5V, I_C = -100mA$		120		MHz
Collector output capacitance	$C_{ob}$	$V_{CB} = -10V, I_E = 0, f = 1MHz$			30	pF

# UTC2SA1201 PNP EPITAXIAL SILICON TRANSISTOR

## CLASSIFICATION OF hFE

RANK	O	Y
RANGE	80 - 160	120 - 240

## TYPICAL PERFORMANCE CHARACTERISTICS

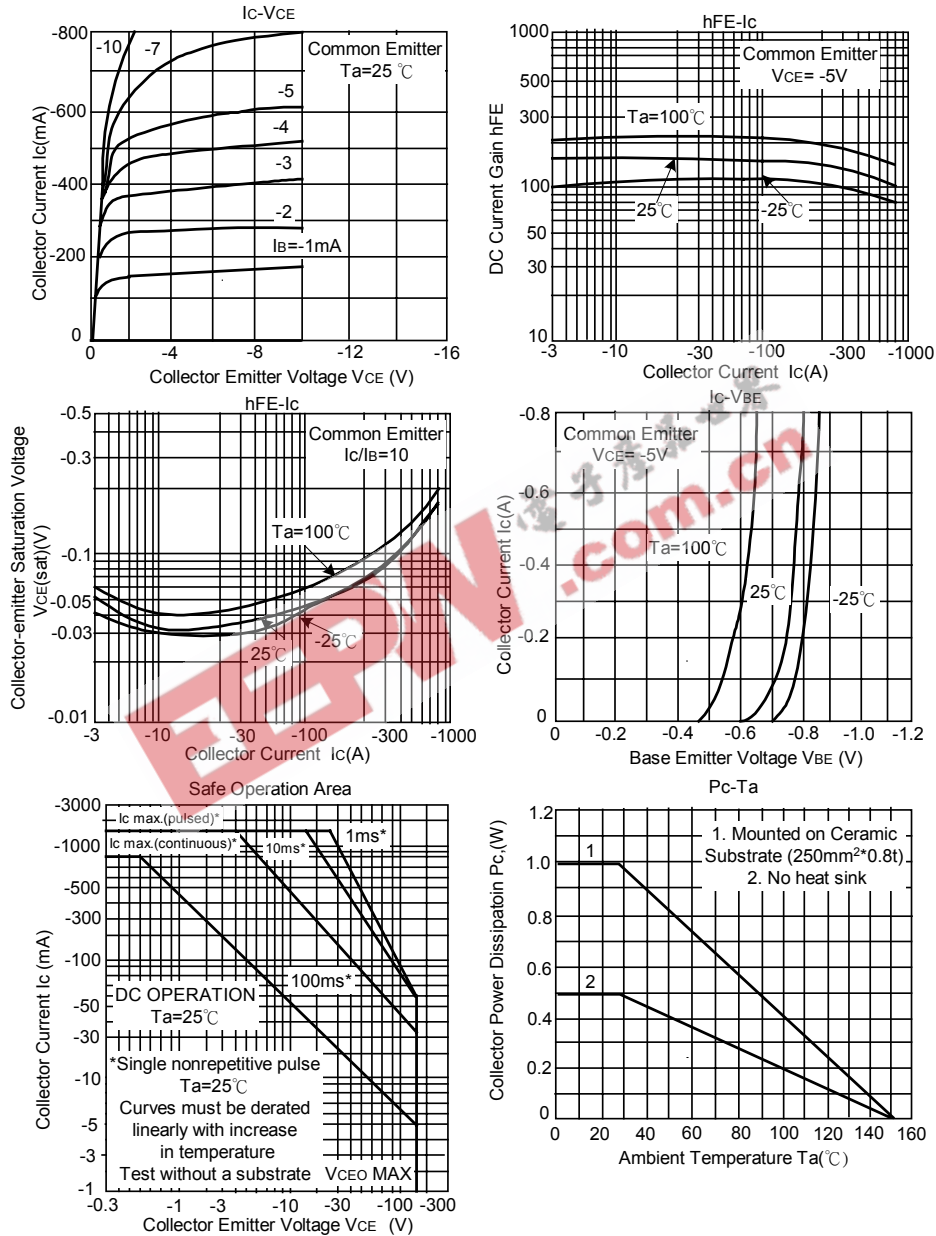

EEPW 电子產品世界  
.com.cn

UTC assumes no responsibility for equipment failures that result from using products at values that exceed, even momentarily, rated values (such as maximum ratings, operating condition ranges, or other parameters) listed in products specifications of any and all UTC products described or contained herein. UTC products are not designed for use in life support appliances, devices or systems where malfunction of these products can be reasonably expected to result in personal injury. Reproduction in whole or in part is prohibited without the prior written consent of the copyright owner. The information presented in this document does not form part of any quotation or contract, is believed to be accurate and reliable and may be changed without notice.