

# 2SA838

Silicon PNP epitaxial planer type

For high-frequency amplification

Complementary to 2SC1359

## Features

- High transition frequency  $f_T$ .

## Absolute Maximum Ratings (Ta=25°C)

Parameter	Symbol	Ratings	Unit
Collector to base voltage	$V_{CBO}$	-30	V
Collector to emitter voltage	$V_{CEO}$	-20	V
Emitter to base voltage	$V_{EBO}$	-5	V
Collector current	$I_C$	-30	mA
Collector power dissipation	$P_C$	250	mW
Junction temperature	$T_j$	150	°C
Storage temperature	$T_{stg}$	-55 ~ +150	°C

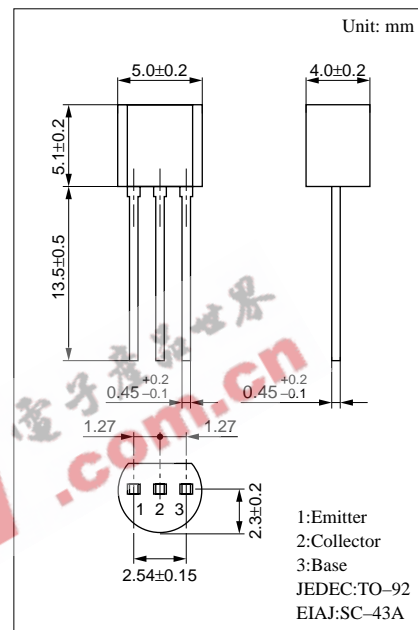

## Electrical Characteristics (Ta=25°C)

Parameter	Symbol	Conditions	min	typ	max	Unit
Collector cutoff current	$I_{CBO}$	$V_{CB} = -10V, I_E = 0$			-0.1	$\mu A$
	$I_{CEO}$	$V_{CE} = -20V, I_B = 0$			-100	
Emitter cutoff current	$I_{EBO}$	$V_{EB} = -5V, I_C = 0$			-10	$\mu A$
Forward current transfer ratio	$h_{FE}^*$	$V_{CE} = -10V, I_C = -1mA$	70		220	
Collector to emitter saturation voltage	$V_{CE(sat)}$	$I_C = -10mA, I_B = -1mA$		-0.1		V
Base to emitter voltage	$V_{BE}$	$V_{CE} = -10V, I_C = -1mA$		-0.7		V
Transition frequency	$f_T$	$V_{CB} = -10V, I_E = 1mA, f = 200MHz$	150	300		MHz
Noise figure	NF	$V_{CB} = -10V, I_E = 1mA, f = 5MHz$		2.8	4.0	dB
Reverse transfer impedance	$Z_{rb}$	$V_{CE} = -10V, I_C = -1mA, f = 2MHz$		22	50	$\Omega$
Common emitter reverse transfer capacitance	$C_{re}$	$V_{CE} = -10V, I_C = -1mA, f = 10.7MHz$		1.2	2.0	pF

\* $h_{FE}$  Rank classification

Rank	B	C
$h_{FE}$	70 ~ 140	110 ~ 220

