

# 2SA921

## Silicon PNP epitaxial planer type

For high breakdown voltage low-noise amplification  
Complementary to 2SC1980

### Features

- High collector to emitter voltage  $V_{CEO}$ .
- Low noise voltage NV.

### Absolute Maximum Ratings (Ta=25°C)

Parameter	Symbol	Ratings	Unit
Collector to base voltage	$V_{CBO}$	-120	V
Collector to emitter voltage	$V_{CEO}$	-120	V
Emitter to base voltage	$V_{EBO}$	-5	V
Peak collector current	$I_{CP}$	-50	mA
Collector current	$I_C$	-20	mA
Collector power dissipation	$P_C$	250	mW
Junction temperature	$T_j$	150	°C
Storage temperature	$T_{stg}$	-55 ~ +150	°C

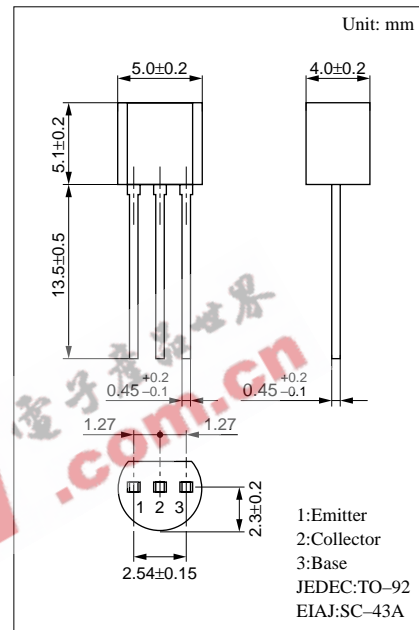

### Electrical Characteristics (Ta=25°C)

Parameter	Symbol	Conditions	min	typ	max	Unit
Collector cutoff current	$I_{CBO}$	$V_{CB} = -50V, I_E = 0$			-100	nA
	$I_{CEO}$	$V_{CE} = -50V, I_B = 0$			-1	μA
Collector to base voltage	$V_{CBO}$	$I_C = -10\mu A, I_E = 0$	-120			V
Collector to emitter voltage	$V_{CEO}$	$I_C = -1mA, I_B = 0$	-120			V
Emitter to base voltage	$V_{EBO}$	$I_E = -10\mu A, I_C = 0$	-5			V
Forward current transfer ratio	$h_{FE}^*$	$V_{CE} = -5V, I_C = -2mA$	180		520	
Collector to emitter saturation voltage	$V_{CE(sat)}$	$I_C = -20mA, I_B = -2mA$			-0.6	V
Transition frequency	$f_T$	$V_{CB} = -5V, I_E = 2mA, f = 200MHz$		200		MHz
Noise voltage	NV	$V_{CE} = -40V, I_C = -1mA, G_V = 80dB$ $R_g = 100k\Omega, \text{Function FLAT}$			150	mV

\* $h_{FE}$  Rank classification

Rank	R	S
$h_{FE}$	180 ~ 360	260 ~ 520

