

2SA1767

Silicon PNP epitaxial planer type

For general amplification
Complementary to 2SC1473A

■ Features

- High collector to emitter voltage V_{CEO} .

■ Absolute Maximum Ratings (Ta=25°C)

Parameter	Symbol	Ratings	Unit
Collector to base voltage	V_{CBO}	-300	V
Collector to emitter voltage	V_{CEO}	-300	V
Emitter to base voltage	V_{EBO}	-5	V
Peak collector current	I_{CP}	-100	mA
Collector current	I_C	-70	mA
Collector power dissipation	P_C	750	mW
Junction temperature	T_j	150	°C
Storage temperature	T_{stg}	-55 ~ +150	°C

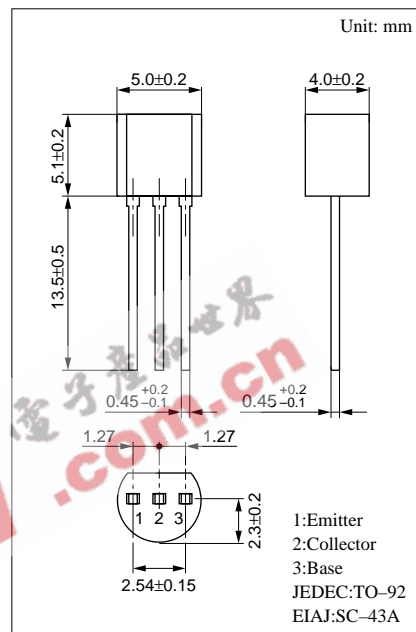

■ Electrical Characteristics (Ta=25°C)

Parameter	Symbol	Conditions	min	typ	max	Unit
Collector to emitter voltage	V_{CEO}	$I_C = -100\mu A, I_B = 0$	-300			V
Emitter to base voltage	V_{EBO}	$I_E = -1\mu A, I_C = 0$	-5			V
Forward current transfer ratio	h_{FE}^*	$V_{CE} = -10V, I_C = -5mA$	60		150	
Collector to emitter saturation voltage	$V_{CE(sat)}$	$I_C = -10mA, I_B = -1mA$			-0.6	V
Transition frequency	f_T	$V_{CB} = -10V, I_E = 10mA, f = 200MHz$		50		MHz
Collector output capacitance	C_{ob}	$V_{CB} = -10V, I_E = 0, f = 1MHz$		7		pF

* h_{FE} Rank classification

Rank	Q
h_{FE}	60 ~ 150

